



Features

- Supports OPC UA
- Supports MQTT
- Supports MODBUS TCP/IP Gateway
- Compact Design and DIN-rail Mountable
- Fan-less Cooling System
- Built-in 256 MB Flash Memory
- Supports MPI 187.5K
- WiFi compatible with 802.11 b/g/n
- Built-in Power Isolator
- Wide input voltage range: 10.5~28VDC

Memory	Flash	256 MB
	RAM	256 MB
Processor		32 bits RISC Cortex-A8 600MHz
I/O Port	SD Card Slot	N/A
	USB Host	N/A
	USB Client	N/A
	Ethernet	10/100 Base-T x 1
	WiFi	IEEE 802.11 b/g/n 802.11b: max 15.88 dBm 802.11g: max 11.92 dBm 802.11n: max 11.28 dBm
	COM Port	COM1: RS-232 2W COM2: RS-485 2W/4W COM3: RS-485 2W
	RS-485 Dual Isolation	N/A
	CAN Bus	N/A
	HDMI	N/A
	Audio Output	N/A
	Video Input	N/A
RTC		Built-in
Power	Input Power	10.5~28VDC
	Power Isolation	Built-in
	Power Consumption	230mA@12VDC;115mA@24VDC
	Voltage Resistance	500VAC (1 min.)
	Isolation Resistance	Exceed 50MΩ at 500VDC
	Vibration Endurance	10 to 25Hz (X, Y, Z direction 2G 30 minutes)
Specification	PCB Coating	Yes
	Enclosure	Plastic
	Dimensions WxHxD	109 x 81 x 27 mm
	Weight	Approx. 0.14 kg
	Mount	35 mm DIN rail mounting
Environment	Protection Structure	IP20
	Storage Temperature	-20° ~ 60°C (-4° ~ 140°F)
	Operating Temperature	0° ~ 50°C (32° ~ 122°F)
	Relative Humidity	10% ~ 90% (non-condensing)
Certificate	CE	CE marked
	UL	Application in progress
Software		EasyBuilder Pro V6.00.01 or later versions

Dimensions

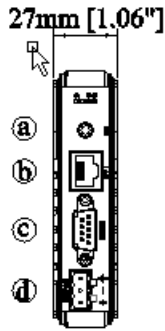

Front View

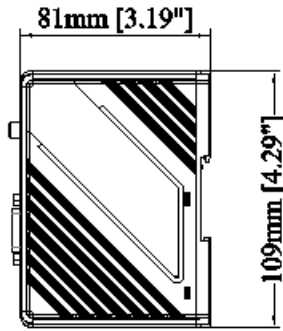

Side View

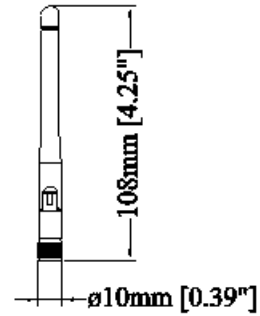

Antenna

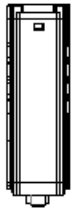

Top View



Bottom View

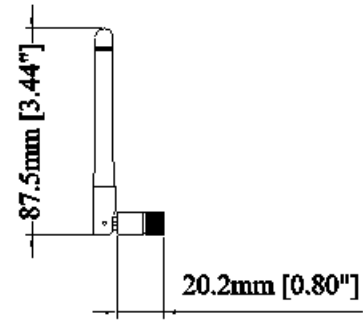

a.	Wifi
b.	Ethernet 1 Port (10M/100M)
c.	COM1: RS-232 2W COM2: RS-485 2W/4W COM3: RS-485 2W
d.	Power Connector
e.	Default Button

Pin Assignment:

COM1 [RS232], COM2 [RS-485 2W/4W], COM3 [RS-485 2W]

Male, 9 Pin, D-sub

PIN#	COM1 [RS232]	COM2 [RS485]		COM3 [RS485]
		2W	4W	
1				Data+
2	RxD			
3	TxD			
4				Data-
5		GND		
6		Data+	Rx+	
7		Data-	Rx-	
8			Tx+	
9			Tx-	

Ordering Information

- cMT-G02:**
Built-in 256 MB Flash / 256 MB RAM on Board
- RZC232300:**
Multi-connector cable COM1[232] / COM2 [485] / COM3 [485]