

Linking your system



Product Features



- Wide measuring range, high precision, low-energy consumption
- Non-contact measurement, no moving parts
- Liquid measurement
- Adopt scientific echo tracking algorithm, capture the real echo effectively
- Adopt temperature compensation(speed, frequency) to make measurement more accuracy and stable
- Analogue output and switches output

Operating principle

Ultrasonic level transmitter operating principle is that it send out ultrasonic pulse and reflected by the medium, the reflected pulse is received by emitter and then transform into electric signal. The distance between emitter and material is in direct proportion to ultrasonic pulse time interval. The distance S and the speed of sound C and the time T can be represented as $S=C*T/2$.

Advantages and main applications

- Advantages:**
- Detection is not effected by below factors:
 - medium density
 - medium electric feature
 - Waves and foam do not affect the sensor
 - The electric devices can be replaced when the lid closed

- Main applications:**
- Level measurement
 - Distance measurement
 - Storage indication
 - Differential level measure
 - Water pump control

Ultrasonic Level Sensors



Ultrasonic level sensors is a kind of non-contact, low-cost, easy-installed level transmitter. It apply space technology to the livelihood industry, this level transmitter has less application limits than other transmitters, more durable, concise appearance, stable function, etc. Widely used in electric power, metallurgy, petrochemical, food industrial, water treatment, paper industrial and level measurement of corrosive liquid.



Wiring Diagram

■ Wiring Diagram

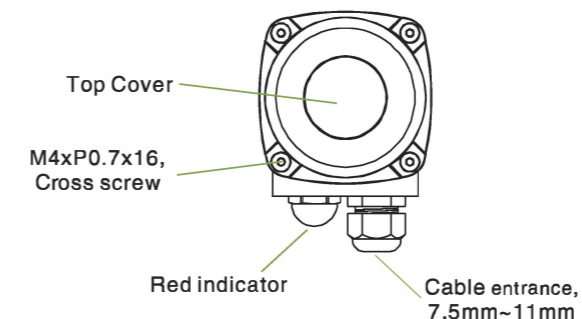

■ Analogue output connection

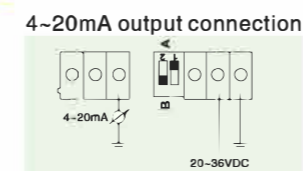

■ NO/NC Output Connection

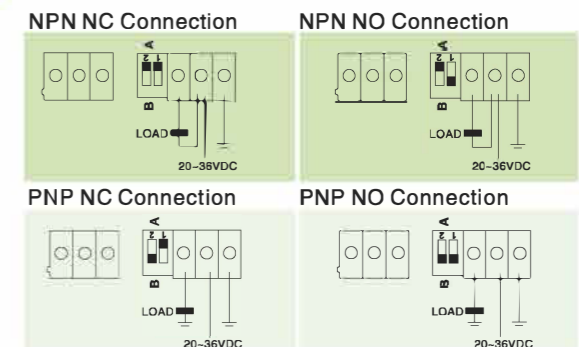

■ Notice

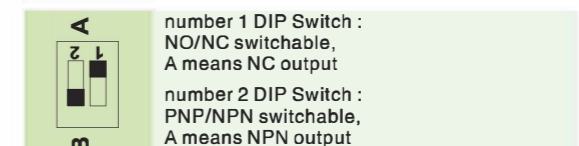

Display

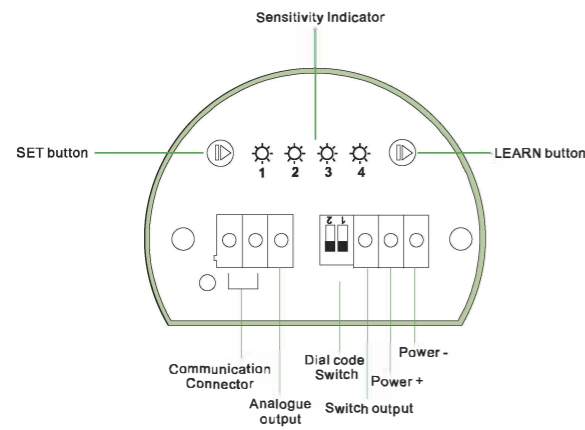

- Panel and Adjustment
- The function of DIP Switch
number 1 DIP switch :NO/NC switching output, A means NC output ;
number 2 DIP switch :PNP/NPN switching output, A means NPN output.
- Buttons Functions
SET: Menu selection;
LEARN: Parameters learning.
- Indicators
The lamp lights on when there is a switching signals, otherwise the light is off.
- Communication connector
It is used for upgrade version, not for this product.

Functions Indication

Functions Indication

	Normally working, lamp 1 flashes
	When the level is higher than Max. point, lamp 2 lights on
	When the level is lower than Min. point, lamp 3 lights on
	Connecting with control box, lamp 4 lights on

This Ultrasonic Level Switch does not support 485 protocols.

■ In operating mode:
press "LEARN" button to examine the adjustment of analogue output.

	Press "LEARN" button, it starts to measure the altitude level and lamp 2,3,4 light on. (ASP is on the upper point and AEP is on the lower Point.)
	Press "LEARN" button, it starts to measure the depth level and, lamp 2,3,4 light on. (Now AEP is on the upper point and ASP is on the lower point.)

■ Unlock Indication:

	Press the two buttons in the meantime once for 5 seconds. The unit is unlock when Lamp 1 and 4 flash.
--	---

Functions and parameters adjustment

Functions and parameters adjustment (under unlock status)

1. Set the Start Point(SP)

	Press SET button, lamp 1 flashes
	Press LEARN button, it starts to learn the current parameters and four lamps flash on in turn
	When the setting is confirmed, lamp 2 and 3 flash
	When the setting is in error, lamp 2 and 3 "flashing alternatively

2. Set the Restrict Point (RP)

	Press SET button, lamp 2 flashes. The following steps are the same as setting the SP
--	--

3. Set the Analogue Start Point (ASP)

	Press SET button, lamp 3 flashes. The following steps are the same as setting the SP
--	--

4. Set the Analogue End Point (AEP)

	Press SET button, lamp 4 flashes. The following steps are the same as setting the SP
--	--

Notice: The frequency of lamp 1 flashes in normal working is different from the flashing frequency of adjusting the parameters.

Function

1.Switching output (See Picture 3 and Table 1)

Table 1:

	Normal Open (NO)	Normal Closed (NC)
Position 1-higher than SP	Yes	No
Position 2-between SP and RP	Delay	Delay
Position 3-below RP	No	Yes

Notice:

- (1) The position of SP must be higher than RP. If the value of SP is lower than RP, the system will automatically adjust the value of RP 1 cm lower than that of SP.
- (2) When the value of SP or RP is out of the measuring range, the learning function would be failed.
- (3) The product features with overload protection. When the output current (PNP or NPN) is over 400mA, it will automatically switch off as a protection. After getting rid of overload, the protection can be removed.

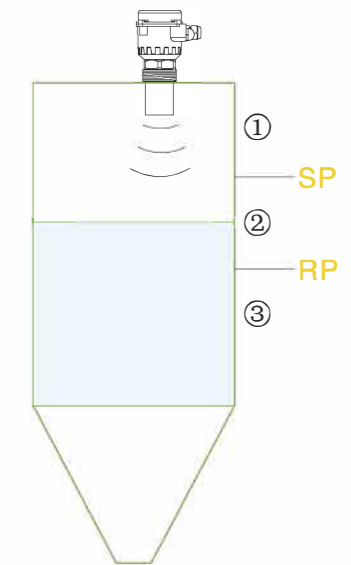

(Picture.3)

2 .Analogue output (See Picture.4 and Table 2)

Table 2:

		Adjustment
Position 1	4mA	ASP on the upper point, AEP on the lower point
	20mA	AEP on the upper point, ASP on the lower point
Position 2	4~20mA is equally allocated from top to down.	ASP on the upper point, AEP on the lower point
	4~20mA is equally allocated from down to top .	AEP on the upper point, ASP on the lower point
Position 3	20mA	ASP on the upper point, AEP on the lower point
	4mA	AEP on the upper point, ASP on the lower point

Notice:

- 1.To ensure the accuracy, the values of ASP and AEP must keep in a proper distance.
- 2.It indicates Error while the value of ASP and AEP are out of the detecting range.
- 3.The value of ASP can be lower than AEP or higher than AEP.

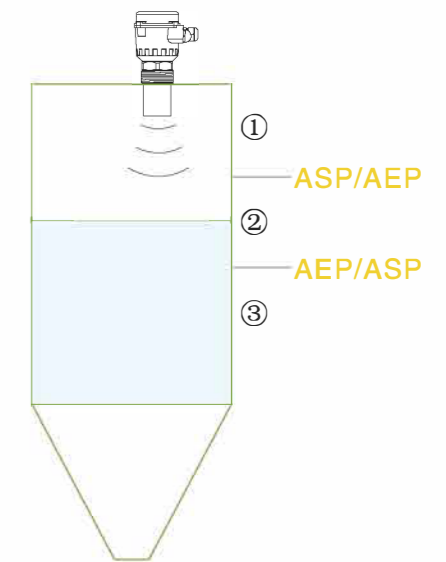

(Picture. 4)

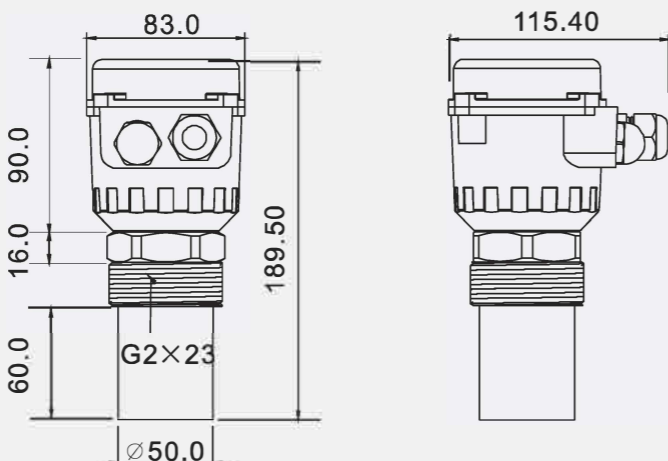
Diagram (mm)	
Model	VS0001
Type	Standard Type
Connection	G2"
Cable entrance	M20xP1.5
Sensing medium	Liquid
Button	two
Operating voltage[VDC]	20...36
Voltage dropping[V]	<3.5
Anti-polarity protection	Yes
Overload protection	Yes
Temperature compensation	Yes
Automatic calibration	Yes
Watch-door dog(Door keeper)	Yes
Current consuming	50
Accuracy deviation [%]	±1%
Minimum Resolution [mm]	1
Output responding [s]	1.5
Output	Three wire, 4~20mA output
Analogue output load [ohm]	4...20mA, Max. (U _b -10V)*50
Switching output Max.load [mA]	400

Switch output specification	NO/ NC adjustable
	NPN/ PNP adjustable
	SP/ RP adjustable
Ambient temperature [°C]	-40~80
Storage temperature [°C]	-40~80
Protection rating	IP65
Resistance [MΩ]	>100(1500 VDC)
Shock resistance [g]	4
Housing material	Aluminum Alloy, ABS, PA+GF
Probe frequency(KHz)	50
Launch angle	<15°
Measuring range (M)	0.3~8
Inactive area(cm)	≤30

Order Information

Order No.	Housing material	Connection	Sensible range (M)	Cable entrance (mm)	Ambient temperature (°C)	Output	Protection
VS0001	Aluminum Alloy	G2"	0.3~8	M20 × P1.5	-40 ~ +80	Three wire, 4~20mA NPN/PNP	IP65

Installation Notice

1. Please install the ultrasonic level sensor at position which is at least 20cm to the vessel wall. Do not install the device in the centerline of tank in order not to receive the false echoes. (See picture 5)
2. Please mount the bottom line of probe being parallel to non-flowing medium. Do not mount the bottom of the device toward filling inlet. It is recommended to install a protective shield if necessary. (See picture 6)
3. Excessively high or low pressure (Vacuum) may reduce the echoes. Please use it within the normal pressure range. Foam or the dust could cause the false echoes which may influence the measuring result. Under such condition, please choose RA series Radar wave level transmitter instead. Ultrasonic level switch is not suitable for the use under extreme temperature.
4. The inactive area is the minimum measured distance between the transmitter face and the medium. When carry out the measurement in the inactive area, it may cause inaccuracy performance. The distance suggested in the table below. The distance should be greater than inactive area (see picture 7) and the measuring value is the distance between the target media and the probe.

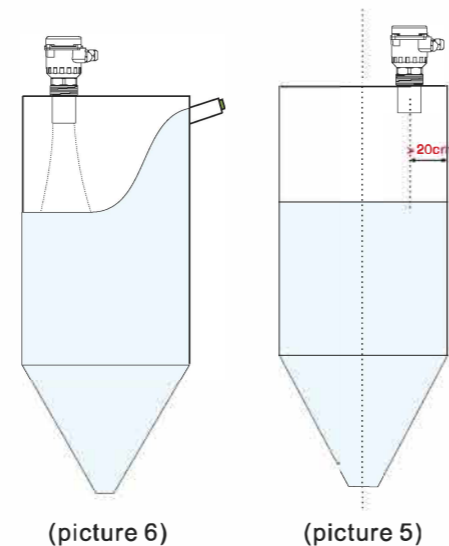

(picture 6) (picture 5)

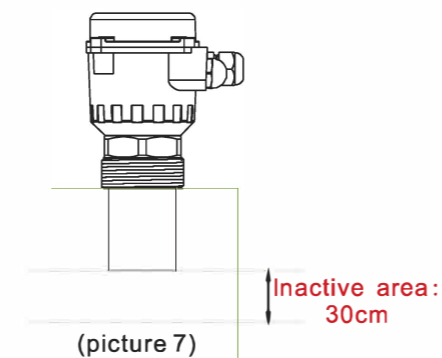

(picture 7)

The unit measure the distance from the process connection of flange or thread

- A. measuring range adjustment
- B. Inactive area
- C. Upper level adjustment
- D. Lower level adjustment

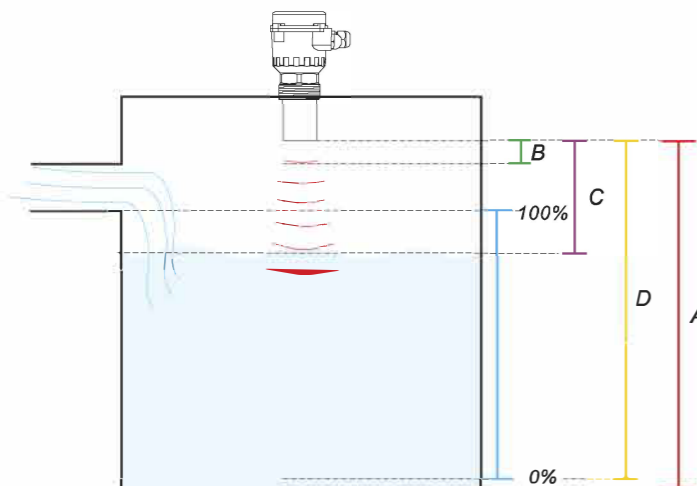

Applications

1. Water or waste water treatment equipment, such as suitable for tank, channel, pool, well, etc.
2. Liquid raw material, such as oil, beverage, heavy oil, etc.
3. Chemical raw material, such as solvent, paint, carbonic acid, water, resin, wax oil, etc.

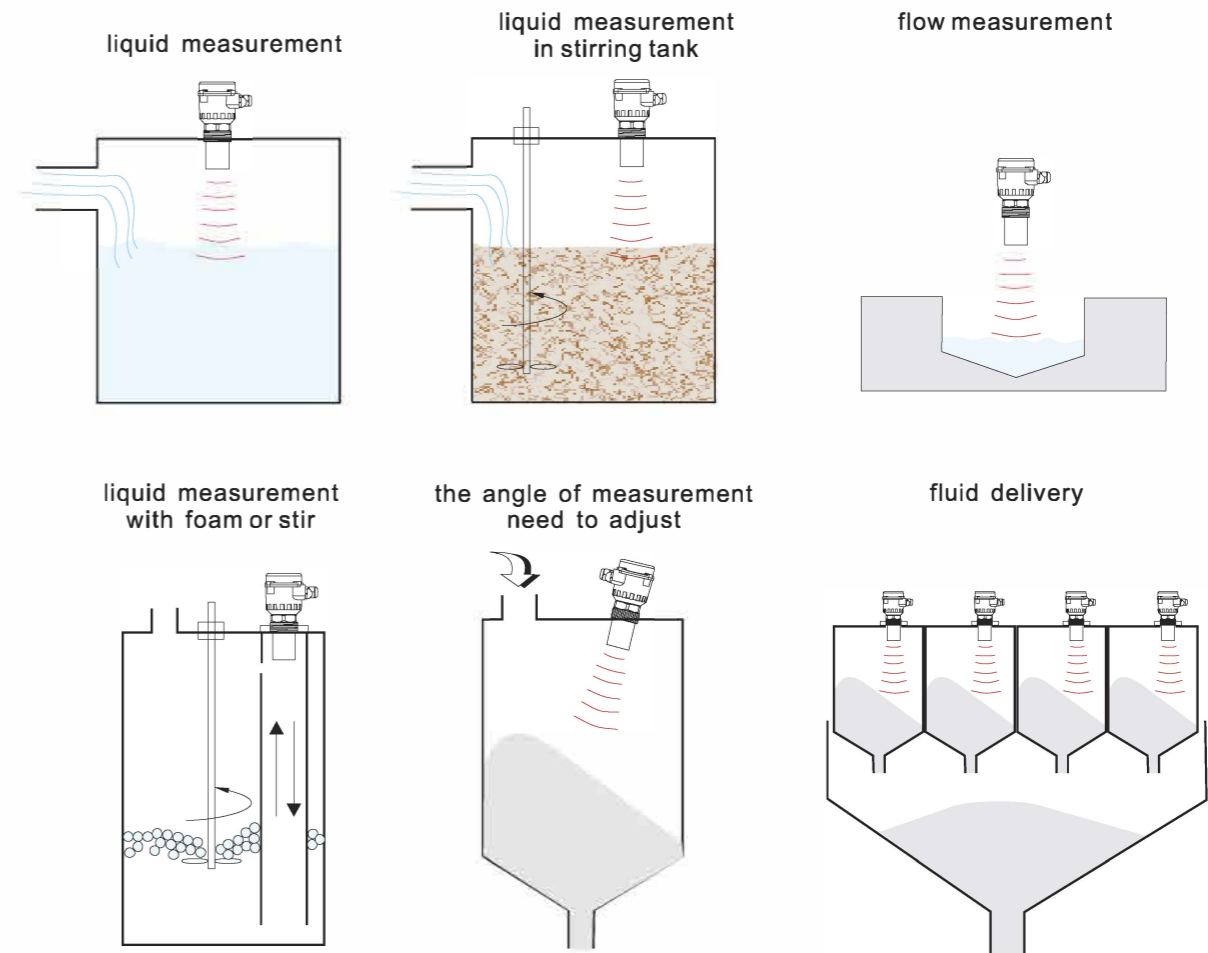

Notice of installation

- 1 Please protect the probe against heavy shocking.
- 2 Please clean the attached materials on the transmitter surface regularly and also keep the surface clean and smooth.



Electrical Connection
The installation must be installed by the experienced specialists; It is necessary to follow the national's installation regulations; The power supply should be off before the connection.