

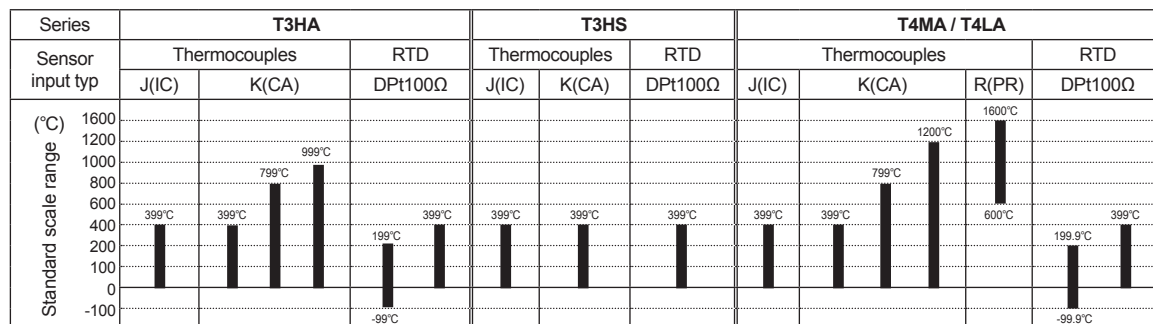

# T3HA/ T3HS/ T4MA/ T4LA

## Temperature range for each sensor



※In case input sensor is R(PR) type, it is not available to perform correct control under 600°C.

## Specifications

Series	T3HA	T3HS	T4MA	T4LA
Power supply	110/220VAC 50/60Hz			
Allowable voltage range	90 to 110% of rated voltage			
Power consumption	Max. 3VA			
Display method	7 Segment(red) LED method			
Character size(W×H)	6.0×10.0mm		7.2×9.8mm	9.5×14.2mm
Display accuracy	F.S. ±0.5% rdg ±1digit			
Setting type	Digital setting			
Setting accuracy	F.S. ±0.5%			
Sensor input	Thermocouples: K(CA), J(IC), R(PR) / RTD: DPT100Ω ※There is no R(PR) in T3HA, T3HS Series.			
Input line resistance	Thermocouples: Max. 100Ω, RTD: Allowable line resistance max. 5Ω per a wire			
Control	ON/OFF control	Hysteresis: F.S. 0.2 to 3% variable		
	P control	Proportional band: F.S. 1 to 10% variable, Period: 20sec. fixed		
Alarm output	SUB	SUB: 0 to -50°C variable		
	Alarm	ALARM width F.S. 0 to 10% variable		
RESET adjuster range	F.S. ±3% variable (revision of control deviation / only for P control)			
Control output	<ul style="list-style-type: none"> <li>Relay contact output: 250VAC 3A 1c</li> <li>SSR drive voltage output: 24VDC ±3V 20mA Max.</li> <li>Current output: DC4-20mA (load 600Ω Max.)</li> </ul>			
	ALARM OUT: 250VAC 1A 1a	SUB OUT: 250VAC 1A 1a	ALARM OUT: 250VAC 1A 1a	ALARM OUT: 250VAC 1A 1c
Self-diagnosis	Built-in burn out function (cut off output when sensor is disconnected)			
Insulation resistance	Min. 100MΩ (at 500VDC megger)			
Dielectric strength	2,000VAC 50/60Hz for 1 min.			
Noise resistance	±1kV the square wave noise(pulse width: 1μs) by the noise simulator			
Vibration	Mechanical	0.75mm amplitude at frequency of 10 to 55Hz (for 1 min.) in each of X, Y, Z directions for 1 hour		
	Malfuction	0.5mm amplitude at frequency of 10 to 55Hz (for 1 min.) in each of X, Y, Z directions for 10 min.		
Shock	Mechanical	300m/s²(approx. 30G) in each of X, Y, Z directions for 3 times		
	Malfuction	100m/s²(approx. 10G) in each of X, Y, Z directions for 3 times		
Relay life cycle	Mechanical	Min. 10,000,000 operations		
	Electrical	Min. 100,000 operations(250VAC 3A at resistive load)		
Environment	Ambient temperature	-10 to 50°C, storage: -25 to 65°C		
	Ambient humidity	35 to 85%RH, storage: 35 to 85%RH		
Unit weight	Approx. 514g	Approx. 517g	Approx. 425g	Approx. 484g

※F.S. is same with sensor measuring temperature range.

Ex) In case of using temperature is from -99.9 to 199.9°C, Full scale is 299.8.

※Environment resistance is rated at no freezing or condensation.

**Autonics**

# Alarm Output type

## ■ Connections

※RTD: DP1100Ω(3-wire type) ※Thermocouple: K, J, R

### ● T3HA, T3HS

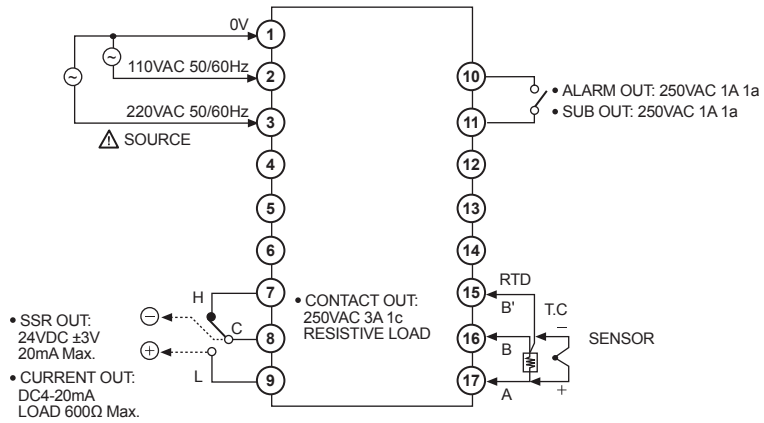

### ● T4MA

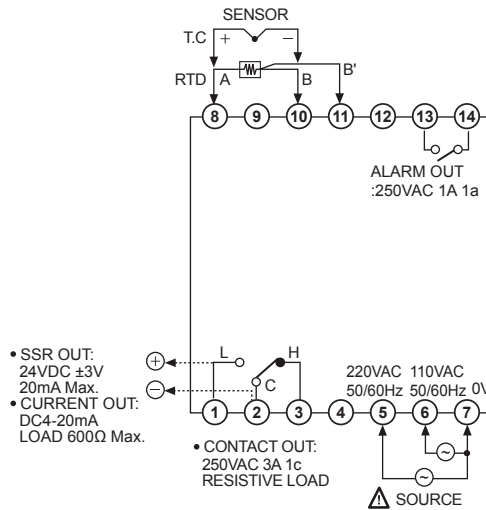

### ● T4LA

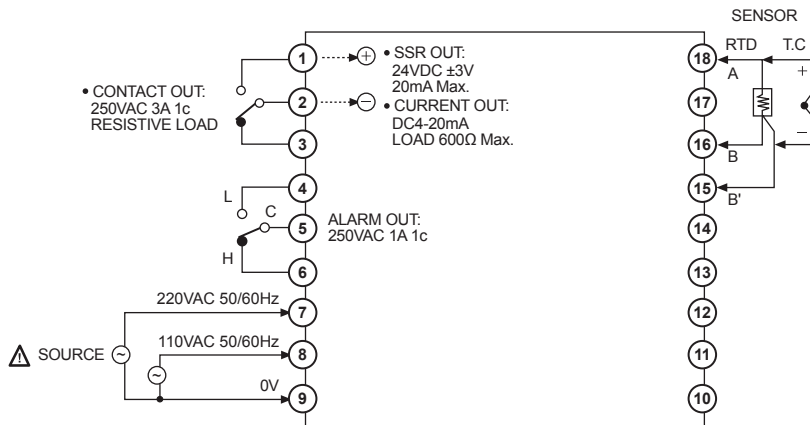

**Autonics**

# T3HA/ T3HS/ T4MA/ T4LA

## ■ Dimensions

(unit: mm)

### ● T3HA, T3HS

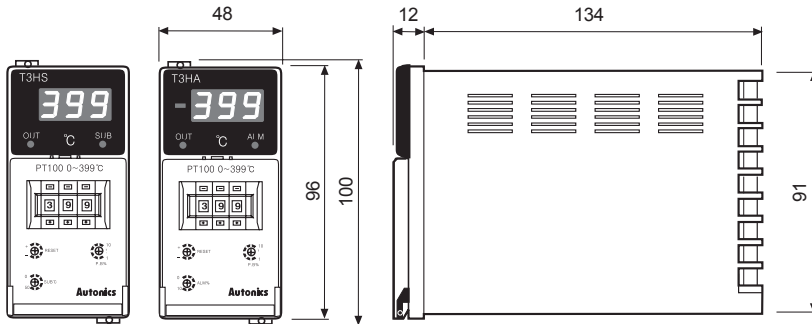

### ● Panel cut-out

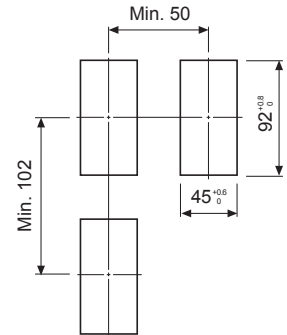

### ● T4MA

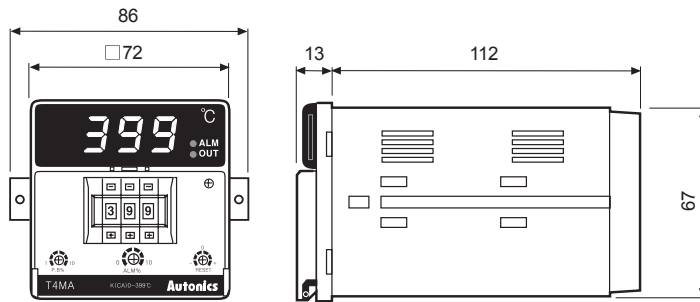

### ● Panel cut-out

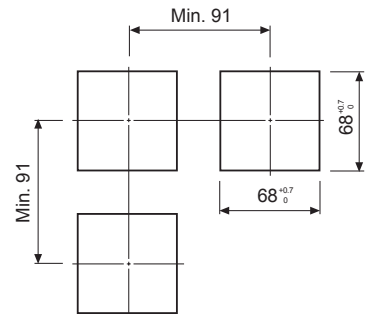

### ● T4LA

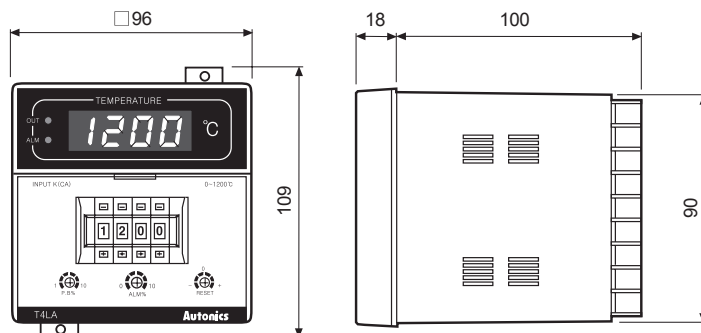

### ● Panel cut-out

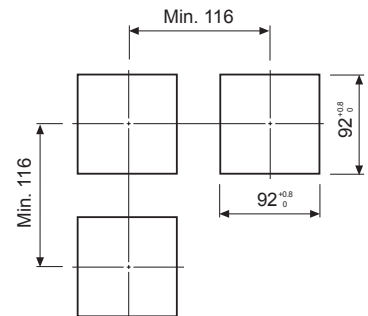

**Autonics**

# Alarm Output type

## ■ Proper usage

### ◎ Using front adjuster

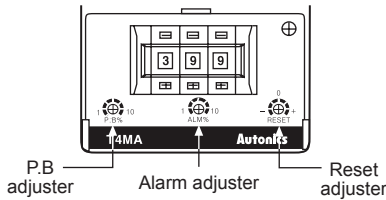

#### ● P.B. adjuster

In case of ON/OFF control, set variable F.S. 0.2 to 3% of hysteresis, and in case of P control, set variable F.S. 1 to 10% of hysteresis.

#### ● Alarm adjuster

It adjusts alarm range(F.S. 0 to 10%) and having 1:1 range for upper and lower limited range by set value.

Ex) In case the full scale of temperature controller is 400°C, if setting alarm range is maximum, the value is  $400^{\circ}\text{C} \times 0.1 = 40^{\circ}\text{C}$ . And the alarm range is high-limit 40°C and lower-limit 40°C.

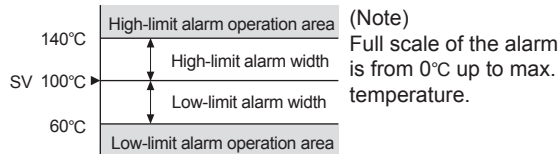

#### ● Reset adjuster

It corrects offset can be occurred by P control and has F.S.  $\pm 3\%$  of adjustable range. Do not operate the adjuster when it is used as ON/OFF control.

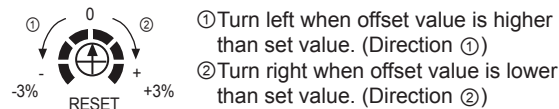

### ◎ Case detachment

#### ● T4MA

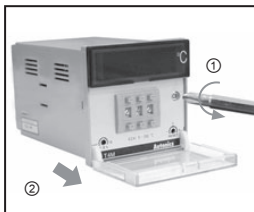

Pressing the front guide of Lock toward ① and squeeze and pull toward ②, it is detached.

#### ● T3HA(S)/T4LA

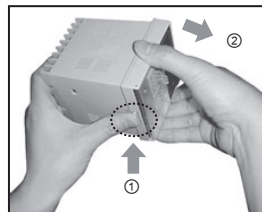

Open the front guide, turn it toward ① and pull toward ②, it is detached.

### ◎ How to select control mode

Factory specification is P control. When using ON/OFF control, transfer the switch of control method from P to F after detaching the case from its body. When control output is current output, P control is fixed, there is no switch Pin of control method.

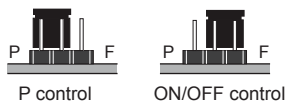

### ◎ Normal/Reverse operation

Reverse operation executes to output ON when processing value is lower than setting value, and it is used for heating. Normal operation is executed conversely and used for cooling. (This item runs as a reverse operation)

### ◎ SUB function (T3HS Series)

SUB output is for alarm used as injector, etc. If the temperature of controlled material reaches to SUB setting value, the SUB output runs and keeps ON continuously.

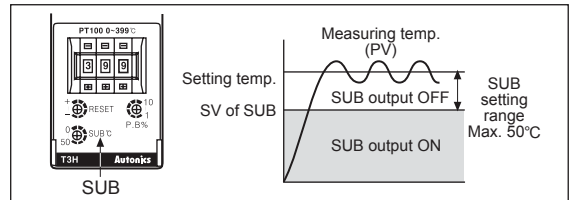

※ SUB function is included only in T3H Series.  
※ SUB range can be set up to 50°C lower than setting value.

### ◎ Application of temperature controller and load connection

#### ● SSR drive voltage output connection

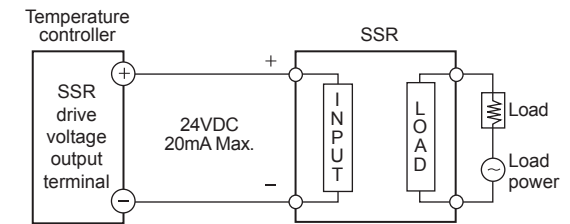

※ When using voltage (for driving SSR) in the other purposes, do not over the range of the rated current.

#### ● Relay output connection

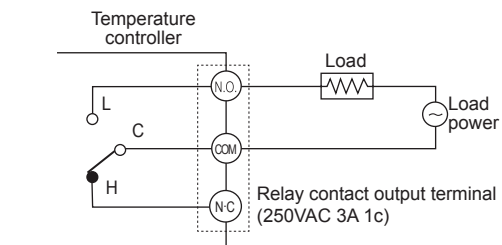

#### ● Current output connection

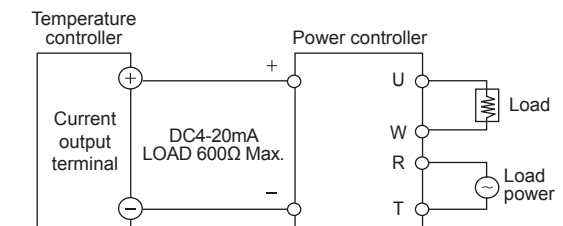

※ The current value of DC4-20mA is available at lower than 600Ω of resistive load.

※ Refer to the H-141 page for caution for using and simple error diagnosis.

**Autonics**