

Operating instructions /
Mounting instructions
Flow sensor

UK

efector300[®]

SF*A**

704181 / 02 06 / 2012





Before installation, read the safety-related section of the operating instructions, enclosed separately!

1 Installation

The sensor tip must be completely immersed in the medium.

- In the case of horizontal pipes mount the unit from the side, if possible (fig. 1).
 - When the unit is to be mounted at the bottom of the pipe, it should be free from deposits.
 - When the unit is to be mounted at the top of the pipe, it should be completely filled with the medium to be monitored.
- In the case of vertical pipes mount the unit in a place where the medium flows upwards (fig. 2).

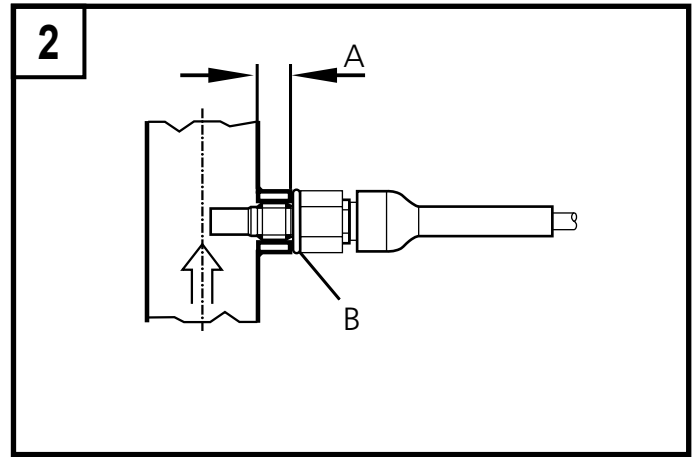
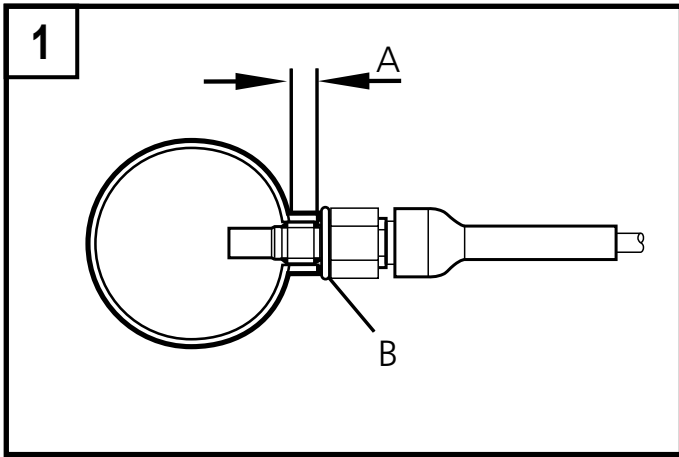

A: mounting bush (15 mm for units with M12 x 1 and G $\frac{1}{4}$ thread; 33 mm for units with G $\frac{1}{2}$ thread).

B: packing washer

To avoid malfunction a minimum distance between the flow monitor and bends, valves or such like must be observed (fig 3). Min. 5 x pipe diameter upstream (A), min. 3 x pipe diameter downstream (B).

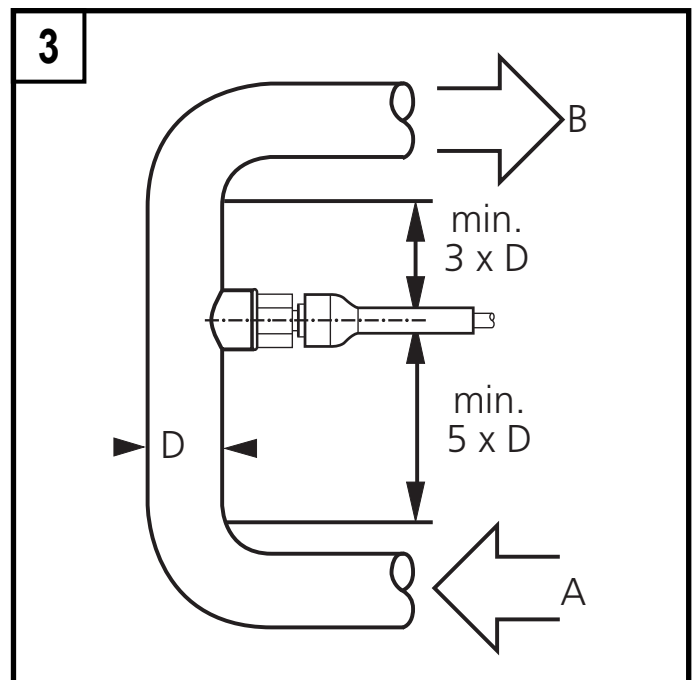

2 Ceramic units

Max. tightening torque: 8Nm for units with G $\frac{1}{4}$ thread; 30Nm for units with G $\frac{1}{2}$ thread.



The thread of the mounting bush must be clean, undamaged and comply with the standard (pipe thread to DIN ISO 228).

For sealing only use flat seals.

3 Flow sensor SF620A

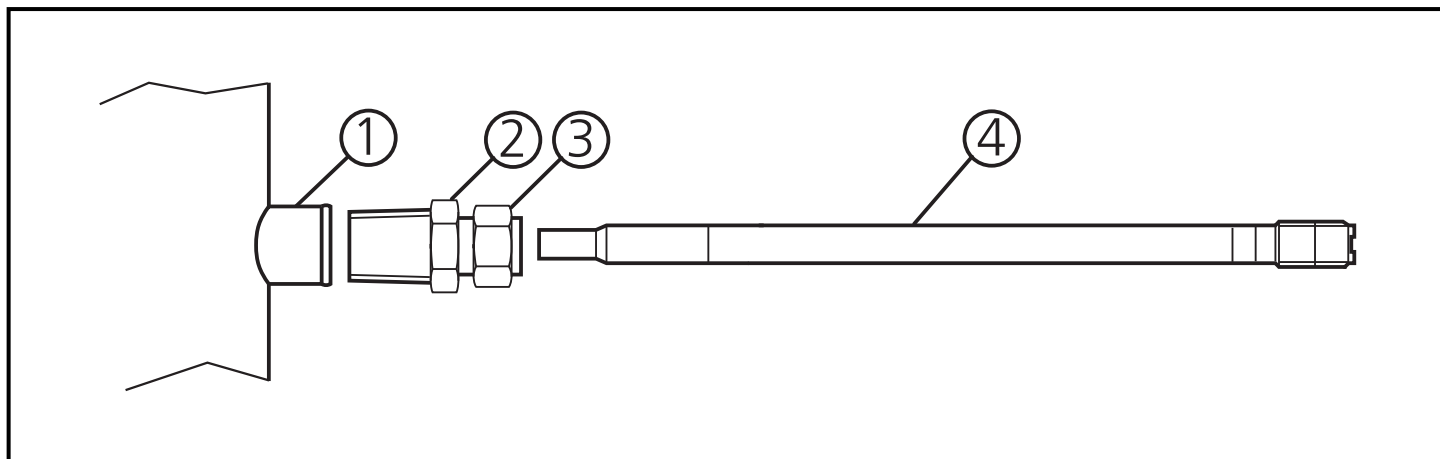

- ▶ Screw the clamp adapter (2) onto the process fitting (1).
- ▶ Insert the flow sensor (4) into the adapter.
- ▶ Set the requested installation length.
- ▶ Tighten the nut (3) (follow the instructions included with the clamp adapter).

Recommended insertion depth of the sensor: 20 ... 30 mm in the pipe. Min. 12 mm, max. to mid pipe.

Note: The sensor tip must not touch the pipe wall.

4 Scale drawings

Category 1/2G	
SF111A	<p>Technical drawing of SF111A scale drawing. The drawing shows a cylindrical component with a central shaft and a threaded section. Dimensions are indicated: total length 55, distance from end to start of main section 13, distance from end to end of main section 27, and distance from end to end of secondary section 12. The secondary section has a thread specification of M12x1 and an outer diameter of Ø8,2. A wrench symbol with the number 17 is shown below the main section.</p>
SF211A	<p>Technical drawing of SF211A scale drawing. The drawing shows a cylindrical component with a central shaft and a threaded section. Dimensions are indicated: total length 55, distance from end to start of main section 13, distance from end to end of main section 27, and distance from end to end of secondary section 12. The secondary section has a thread specification of G1/4 and an outer diameter of Ø8,2. A wrench symbol with the number 17 is shown below the main section.</p>
SF311A	<p>Technical drawing of SF311A scale drawing. The drawing shows a cylindrical component with a central shaft and a threaded section. Dimensions are indicated: total length 75, distance from end to start of main section 15, distance from end to end of main section 45, and distance from end to end of secondary section 12. The secondary section has a thread specification of G1/2 and an outer diameter of Ø8,2. A wrench symbol with the number 27 is shown below the main section.</p>

Category 2G / Cable

SF121A

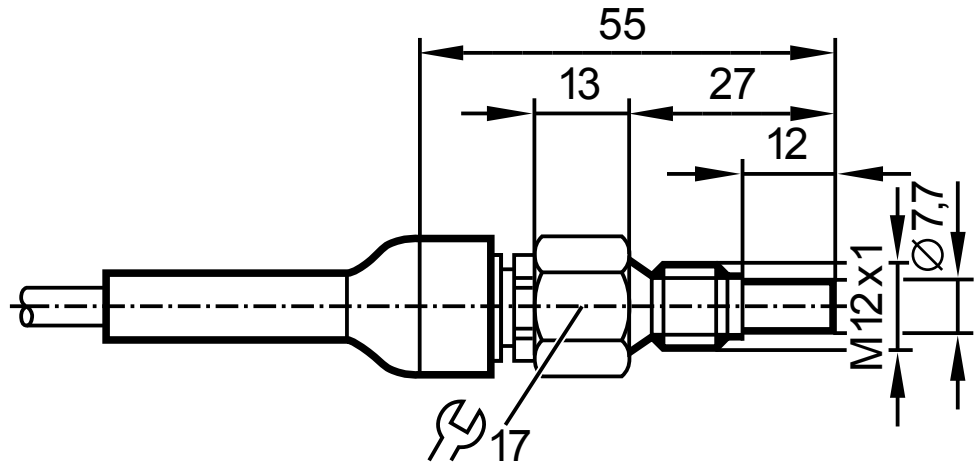

SF221A

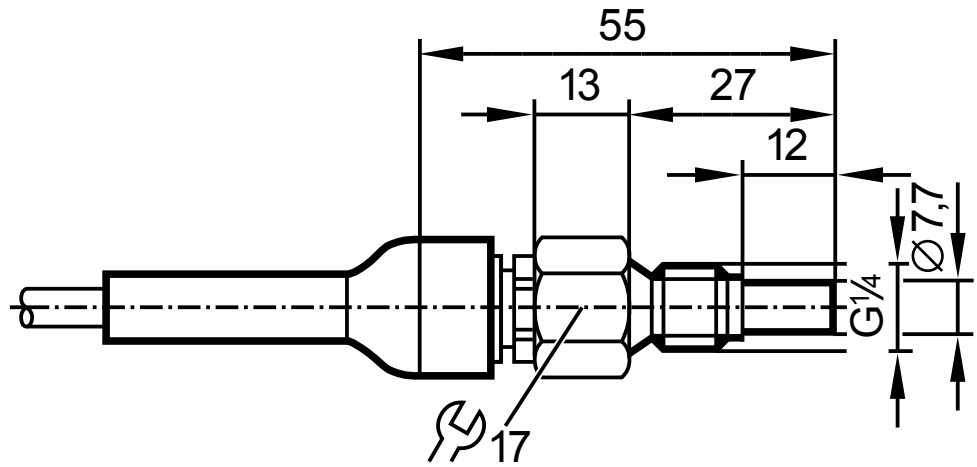

SF321A

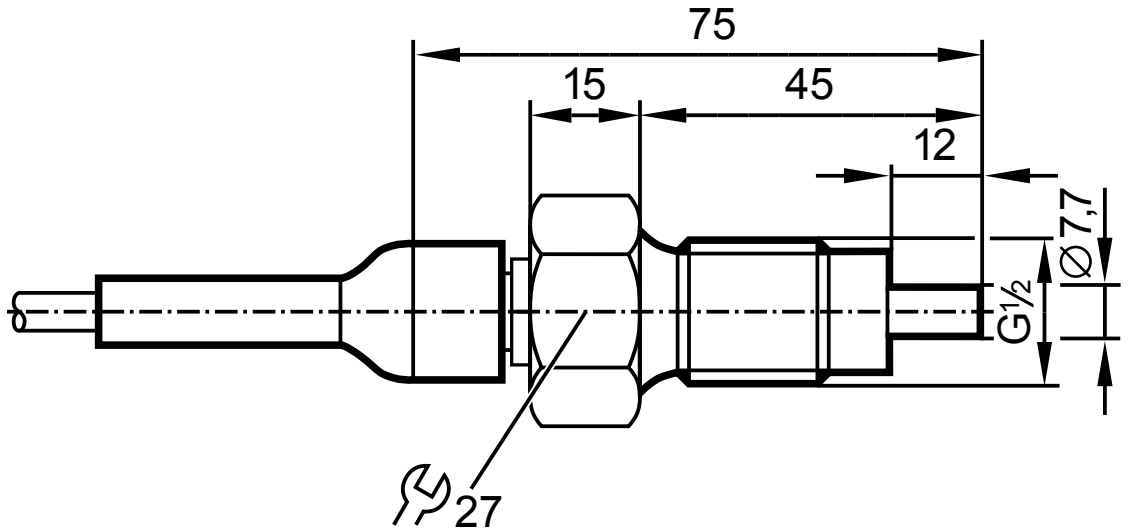

UK

Category 2G / Plug

SF120A

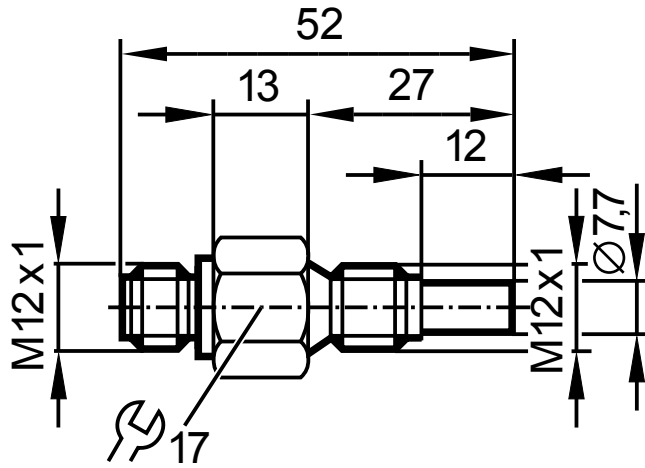

SF220A

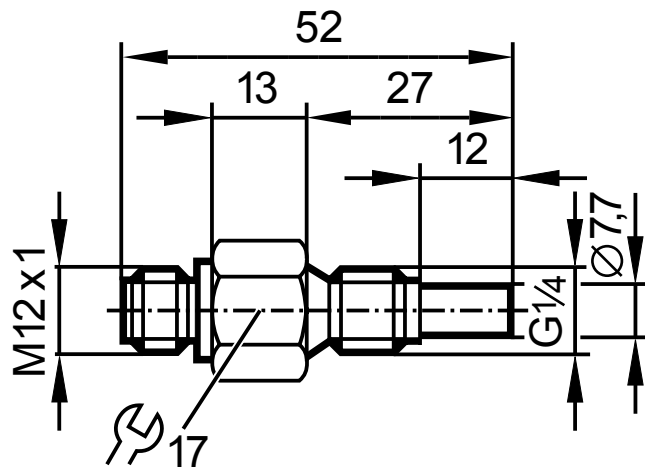

SF320A

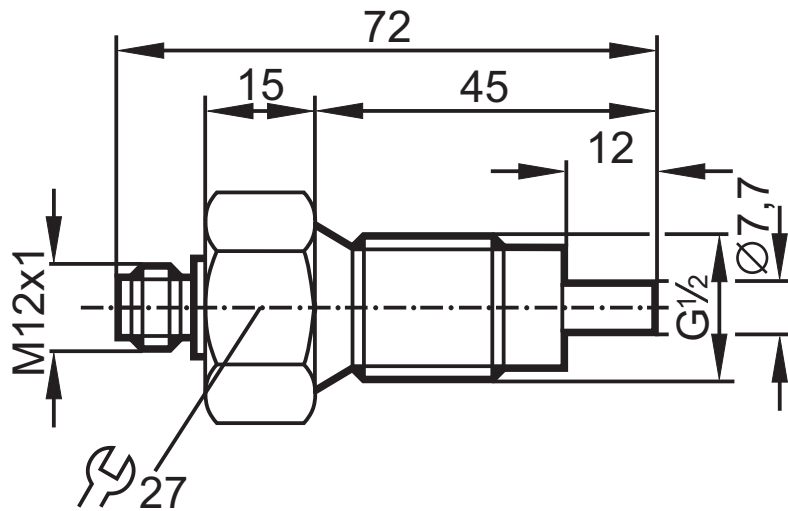

SF620A

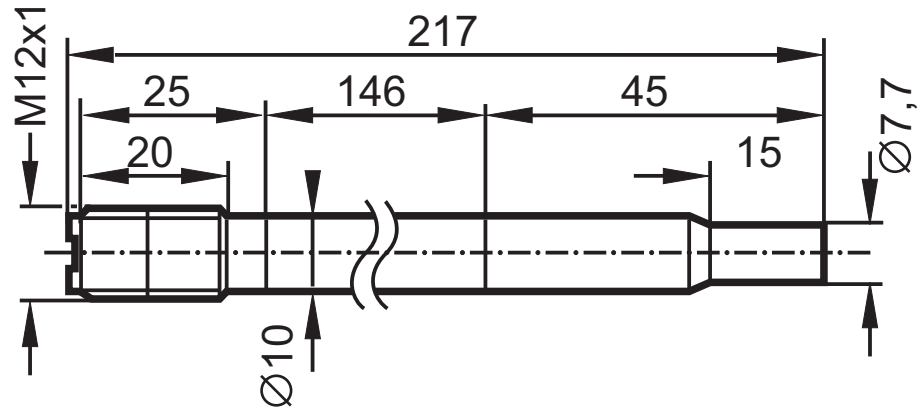

UK

Category 2G / Ceramic units

SF223A

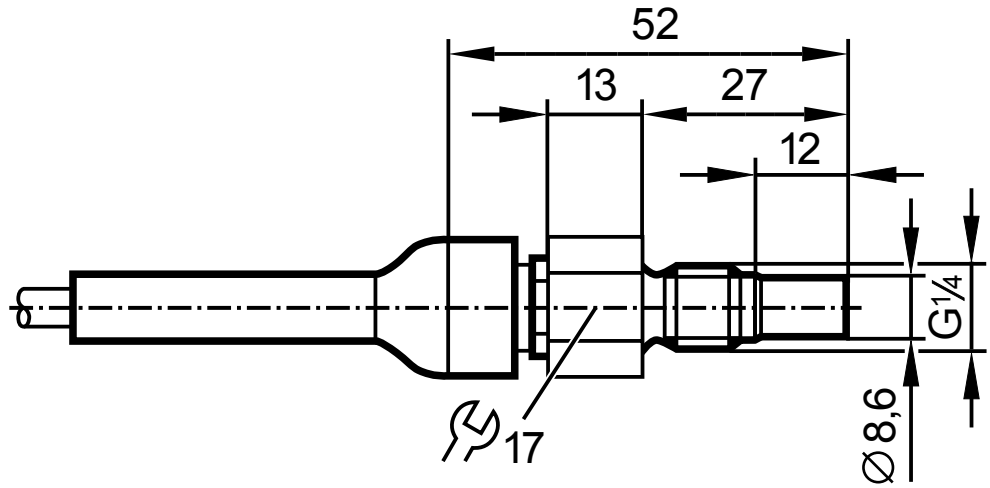

SF323A

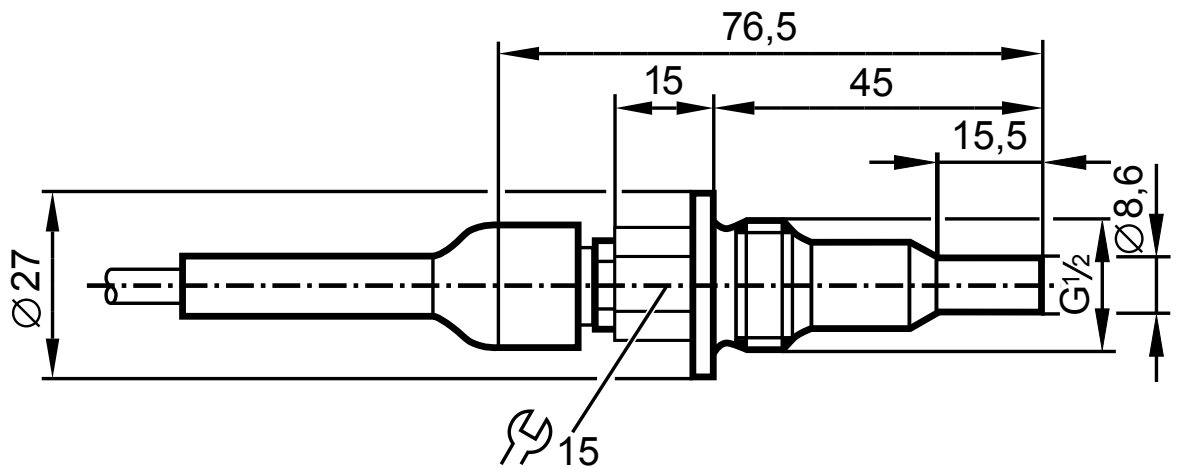

Category 2G / ANSIB16.5 (1in; 300 lb/sq.in)

SF521A

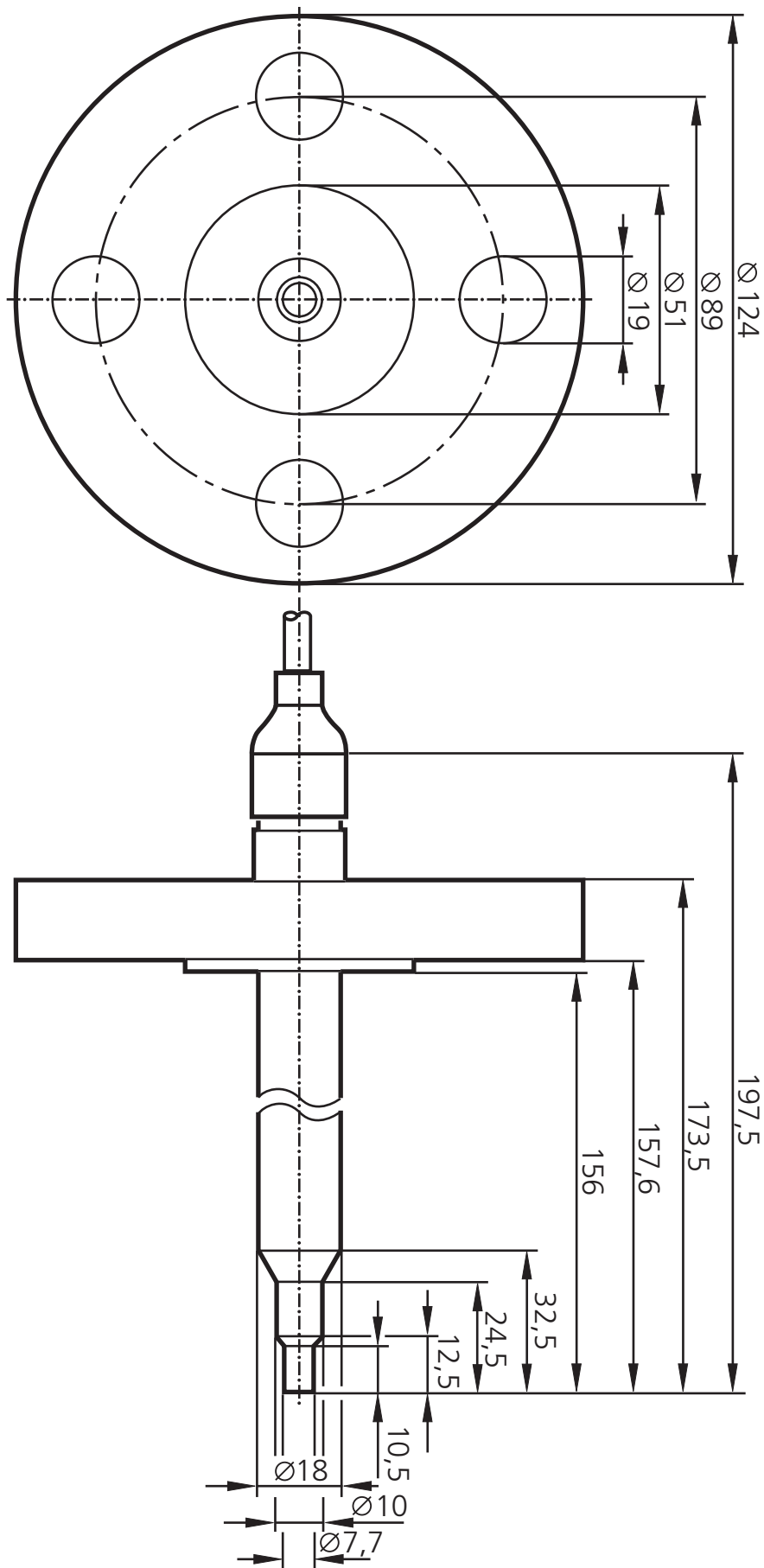

ООО "РусАвтоматизация"

454010 г. Челябинск, ул. Гагарина 5, оф. 507
тел. 8-800-775-09-57 (звонок бесплатный), +7(351)799-54-26, тел./факс +7(351)211-64-57
info@rusautomation.ru; rusавтоматизация.рф; www.rusautomation.ru