

DESCRIPTION

The RCT1000 Coriolis mass flow meter identifies flow rate by directly measuring mass flow and density of fluids over a wide range of process temperatures with a high degree of accuracy. For homogenous fluids consisting of two components like sugar and water, the RCT1000 Coriolis system can derive the concentration and mass of each component based on fluid properties and density measurement. Furthermore, the unobstructed, open flow design makes it suitable for a variety of fluids such as slurries and other viscous, nonconductive fluids that are difficult to measure with other technologies.

APPLICATIONS

The Coriolis design and measurement principle allows the meter to be an exceptional device in measuring:

- Adhesives, glues or binding materials
- Coatings and hardeners
- Dyes, fragrances, vitamins and other additives
- Homogeneous suspensions
- Vegetable oils and fats

OPERATION

Coriolis flow meters simultaneously measure mass flow rate, density and temperature. As fluid flows through the vibrating sensor tube, forces induced by the flow cause the tube to twist slightly. These small deflections are measured by carefully placed detectors. A phase shift occurs between detector signals that is directly proportional to mass flow rate. As the fluid density varies, the resonant frequency at which the tube vibrates changes, which is also measured by the detectors. Temperature is measured by an internal RTD in order to calculate thermal effects on the tube vibrating frequency and can be used as a measurement output.

CONTROLS SYSTEM INTEGRATION

RCT1000 transmitters provide a variety of means to integrate the meter's output into new and existing operations. The batch and PID functionality enables direct control of devices, such as valves, by use of digital or analog outputs. Additionally, programmable digital outputs can indicate low and high alarm conditions. Network options are available including EtherNet/IP, Modbus TCP/IP and Modbus RTU.



MAINTENANCE

With no internal moving parts, the vibrating tube design has little impact on mechanical wear, resulting in a longer life expectancy and in fewer repairs than many other flow technologies.

FLUID DIAGNOSTICS

RCT Console software offers much more than configuration features. Users can obtain advanced data logging and performance trending analysis, as well as system verification provided by the unique HealthTrack feature, which captures critical operation parameters.

ADVANTAGES

- Highly accurate direct measurement of:
 - ◊ Mass flow
 - ◊ Density
- Derive concentration of homogenous liquids containing two components
- Open flow path
- No straight-run requirements
- Low maintenance operation
- Flexible integration options
- Advanced fluid diagnostic software

SPECIFICATIONS

The complete remote mount metering system consists of the following; each component must be purchased separately:

- Sensor
- Transmitter
- Cable assembly

System with RCS005/RCS008 Sensors

Uncertainty	Mass Flow Rate (Liquids)	RCS005	± 0.1% for flow rate > 0.05 lb/min ± 0.00005 lb/min for flow rate ≤ 0.05 lb/min
		RCS008	± 0.1% for flow rate > 0.2 lb/min ± 0.0002 lb/min for flow rate ≤ 0.2 lb/min
Density	±0.12486 lb/ft ³ (0.002 g/cm ³)		
Repeatability	±0.05% of reading ± zero stability		
Zero Stability	RCS005	±0.00005 lb/min	
	RCS008	± 0.0002 lb/min	
Safety Certifications	Ordinary Location	UL61010-1/CSA C22.2 No. 61010-1:2010	
Density Measurement	Flowing, referenced, API, Brix, Baume and net oil		
Conformance	CE		

Flow Rate Specifications

Model	Nominal Line and Equivalent Pipe Size	Number of Flow Tubes	Flow Range		Volumetric Equivalent 1 g/cm ³	
			lb/min	kg/hr	gal/min	l/h
RCS005	1/4 in., 1/16 in.	1	0...1.25	0...34	0.124	34
RCS008	1/4 in., 3/32 in.	1	0...2.75	0...74.8	0.274	74.8

Sensors

Pressure	Model	Maximum Allowable Pressure
	RCS005	2755 psi (190 bar)
	RCS008	1800 psi (124 bar)
Wetted Materials	Standard	316L stainless steel
Temperature	Fluid Range	-40...392° F (-40...200° C)
	Accuracy	±1.8° F (1° C)
	Repeatability	±0.54° F (0.3° C)
Process Connections	1/4 in. O-ring face sealing; NPT	
Conformance	ASME B31.3 Pressure Piping Hydro Test NACE MR0175/ISO 15156	

Transmitter

Enclosure	NEMA 4 [IP-65]; powder coated aluminum, polycarbonate, urethane and stainless steel	
Power Requirements (Standard with Every RCTN Transmitter)	115/230V AC	±15% 50/60 Hz 25 W maximum
	20...28V DC	15 W maximum
Ambient Temperature	14...158° F (-10...70° C)	
Configuration	Four-button HMI or RCT Console configuration	
Display	4 line × 20 character; alpha-numeric; dot matrix; LED backlighting	
RTD Input	Standard (1 input)	Built-in 100 Ω Platinum RTD within the sensor body
	Optional (1 auxiliary input)	Additional 100 Ω 3-wire Platinum RTD input for the secondary RTD is used by customers who want to be able to calibrate their RTD
Analog I/O	Outputs	Three 4...20 mA (0...22 mA capable), maximum load 500 Ω, approximately 16 bit resolution outputs; assignable to mass flow, volume, density, temperature, concentration, PID and similar measurements. User defined fault condition output value anywhere in the 0...22 mA range
	Inputs	Two 0...5V DC inputs. 20k Ω input impedance, approximately 12 bit resolution
Auxiliary Power	Internal 24V DC supply, 100 mA maximum (for batching functions, frequency output channel and like applications)	
Frequency/Pulse Output	One open collector transistor, user configurable as rate (3 kHz max output), accumulator 0...10 Hz; PWM with 1 kHz carrier	
	User assignable to rate, any totalizer, PID, temperature, density, concentration or other similar measurements.	
Digital I/O	Outputs	Four 5...28V DC, 50 mA maximum current draw (external pullup resistor required)
	Inputs	Four 5...24V DC, 1 k Ω impedance
Industrial Communications Modular Port	Standard	Modbus RTU (EIA-485/RS485)
	Optional Module	Modbus TCP/IP & EtherNet/IP
Standard Configuration Port	USB 2.0 interface (through a Mini-B receptacle) for RCT Console software	
Alarms	Six Hi/Lo Alarms; Alarm status on display by default, assignable to digital I/O (limit 2 or 4) and available via digital communications	
Transmission Distance	Up to 100 ft (30 meters); contact factory if longer length is needed	
Other Functions	Batch control, PID control. User configuration of all I/O functions	
Measurements	Forward and reverse mass flow and total, density, temperature; concentration, volumetric flow and total (derived)	

CABLE KITS

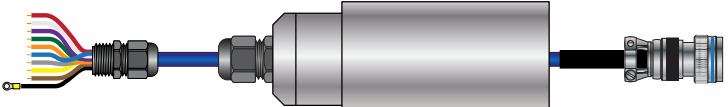
The kits include the cable assembly, cable protector and sensor cable connection cover.			
RC820476-20	Kit, PVC jacketed cable 20 ft	Temp range: -40...176° F (-40...80° C)	
RC820476-35	Kit, PVC jacketed cable 35 ft		
RC820476-50	Kit, PVC jacketed cable 50 ft		
RC820476-70	Kit, PVC jacketed cable 70 ft		
RC820476-100	Kit, PVC jacketed cable 100 ft	Temp range: -94...392° F (-70...200° C)	
RC820477-20	Kit, FEP jacketed cable 20 ft		
RC820477-35	Kit, FEP jacketed cable 35 ft		
RC820477-50	Kit, FEP jacketed cable 50 ft		
RC820477-70	Kit, FEP jacketed cable 70 ft		
RC820477-100	Kit, FEP jacketed cable 100 ft		

DIMENSIONS

Electronics Enclosure

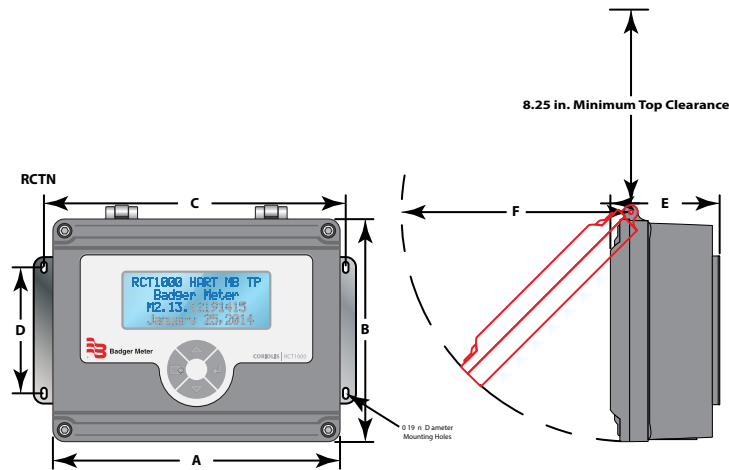

A	B	C	D	E	F
9.80 in. (249.9 mm)	8.00 in. (203.2 mm)	10.30 in. (261.6 mm)	4.30 in. (109.2 mm)	3.66 in. (93.0 mm)	8.32 in. (211.2 mm)

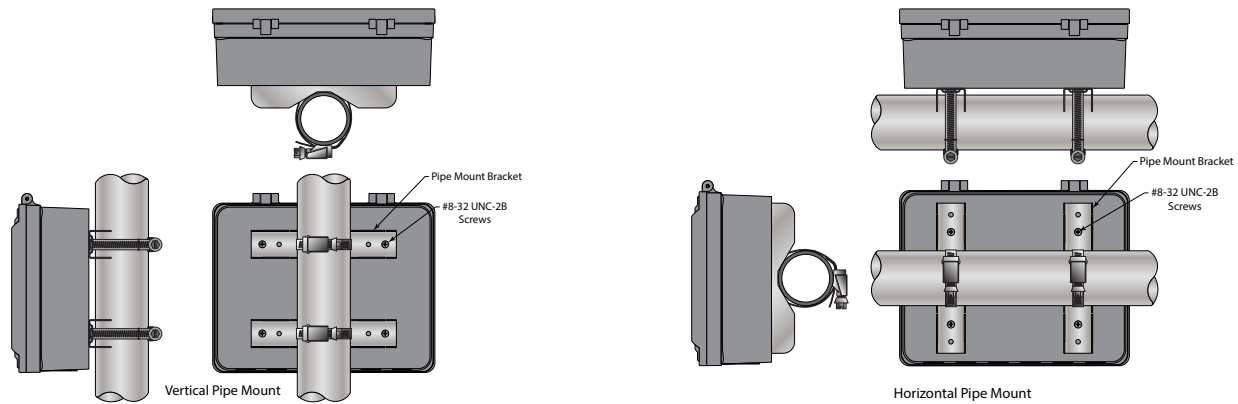

RCTN Pipe Mounting Options

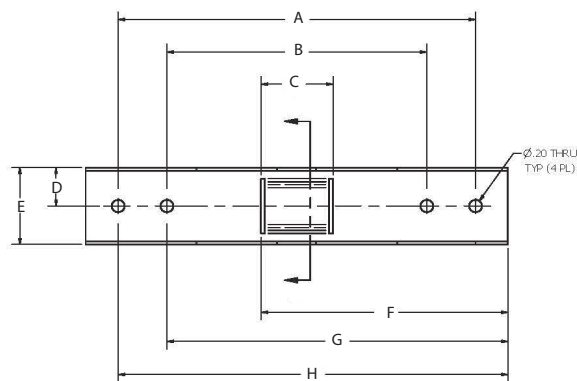

Pipe Bracket Dimensions

A	B	C	D	E	F	G	H
5.50 in. (139.7 mm)	4.00 in. (101.6 mm)	1.11 in. (28.2 mm)	0.625 in. (15.9 mm)	1.25 in. (31.8 mm)	3.80 in. (96.5 mm)	5.25 in. (133.6 mm)	6.00 in. (152.4 mm)

Sensor Dimensions, RCS005

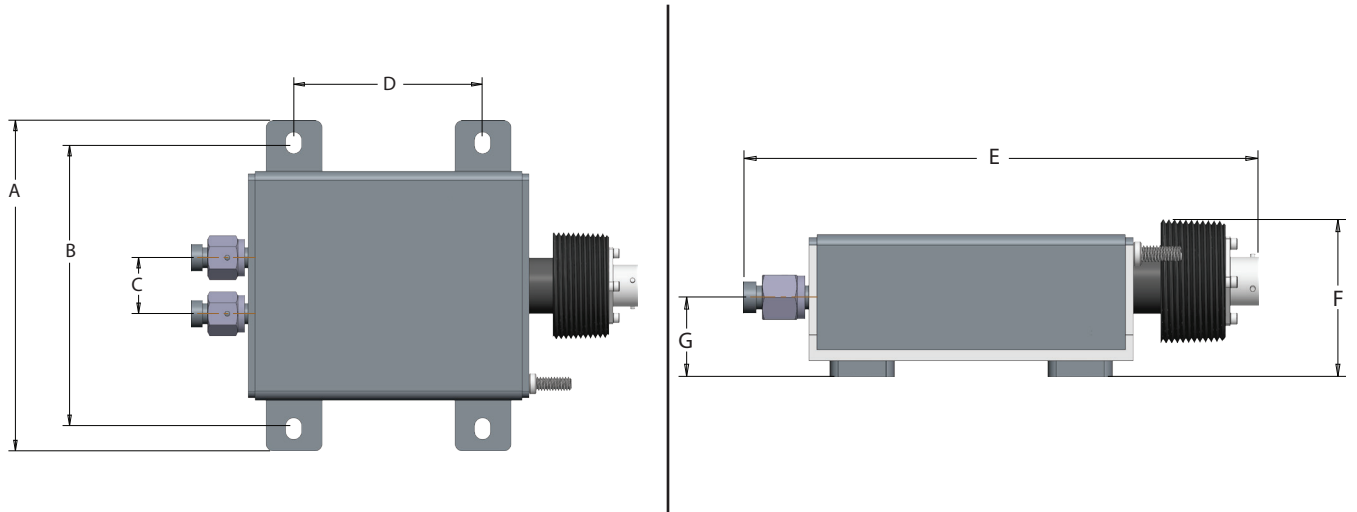

Sensor	Nominal Size	A	B	C	D	E	F	G
RCS005	1/4 in.	5.90 in. (149.9 mm)	5.00 in. (127 mm)	1.00 in. (25.4 mm)	3.60 in. (85.3 mm)	7.93 in. (201.7 mm)	2.42 in. (61.6 mm)	1.23 in. (31.2 mm)

Sensor Dimensions, RCS008

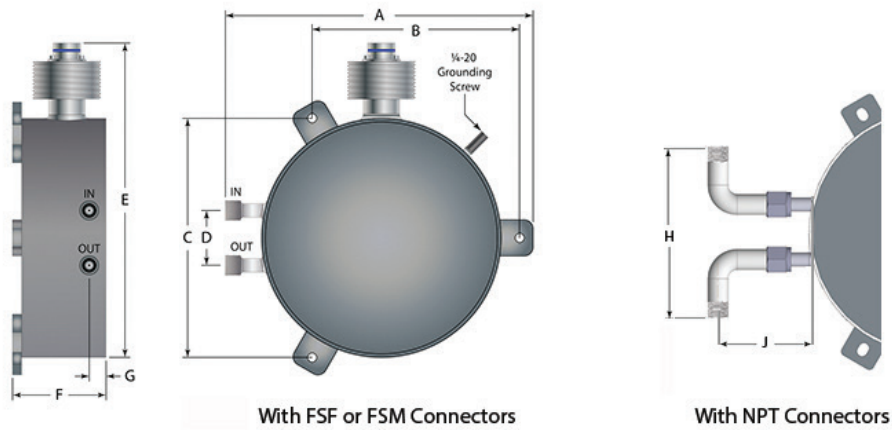

Figure 1: RCS008 dimensions

Sensor	Nominal Size	A	B	C	D	E	F	G	H	J
RCS008	1/4 in.	8.48 in. (215.3 mm)	5.72 in. (145.3 mm)	6.60 in. (167.7 mm)	1.50 in. (38.1 mm)	8.70 in. (221 mm)	2.67 in. (67.8 mm)	0.98 in. (24.9 mm)	4.65 in. (118 mm)	2.48 in. (63 mm)

APPROXIMATE SHIPPING WEIGHTS

Model	Sensor Only		Model	Cables Only		
	Weight	Weight		Weight	Weight	
RCS005	5.5 lb	2.49 kg	RC820***-20	6 lb	2.7 kg	
RCS008	9.7 lb	4.4 kg	RC820***-35	8 lb	3.6 kg	
Model	Transmitter Only		Model	Cables Only		
RCTN	6.5 lb	2.95 kg		RC820***-50	10 lb	4.5 kg
				RC820***-70	13 lb	5.9 kg
			RC820***-100	17 lb	7.7 kg	

NETWORK OPTIONS

RS-485 Network	All RCT1000 meters come equipped an EIA-485 port with Modbus RTU..
10/100 Base-T Network	An optional Ethernet module allows communications via Modbus TCP/IP or EtherNet/IP.

SOFTWARE UTILITY

RCT Console software is a PC-based software that can be used to configure, operate and diagnose the RCT1000 Coriolis meter. Additionally, the software can log and graph fluid characteristics and parameters for historical comparisons. RCT Console software is included with the RCT1000 Coriolis meter.

Sample	Time [s]	33. Phase [μs]	60. Tube Frequency [Hz]	183. Coil A Voltage [mV]	184. Driver Output [%]	185. Coil B Voltage [mV]
1	0.359	-0.018321750689572624	88.507232666015625	60.0019416809062	69.021713256839937	59.978321075439453
2	1.046	0.008950438973426319	88.516281127929688	59.999141693115234	69.029747009277344	59.97899714029375
3	2.075	0.044337108731289836	88.521278381347856	60.000060108642678	69.03057861328125	59.9730110165457
4	3.106	-0.058853188683523407	88.511688232421875	60.009830474853816	69.027748107910156	59.9715680612793
5	4.134	0.021695289760828018	88.5119637084961	59.991420745849609	69.026771545410156	59.969928741455078
6	5.164	0.0785641223192215	88.512863159179688	59.994338895257813	69.041763305664063	59.967928640087891
7	6.193	0.0290124022910582	88.509567260742187	59.99884033203125	69.036247253417969	59.965499877929688
8	7.223	0.066253632307052612	88.510772705078125	59.999370574951172	69.035362243652344	59.967361450195313
9	8.253	0.06153648367786407	88.491180419921875	59.990581512451172	69.039588928222656	59.9675407409668
10	9.282	-0.1050340011715889	88.511962890625	59.99462890625	69.03460683359375	59.963081358863281
11	10.312	-0.015941370278596878	88.50128173828125	60.005199432373047	69.028480529785156	59.986789703369141
12	11.341	-0.0639564497923851	88.497077941894531	60.016311645907813	69.017707824707031	59.9633930503418
13	12.37	-0.0002319063842965	88.506942748023438	59.991747085712891	69.020945642089844	59.97145843505894
14	13.167	0.11063340306282043	88.502738952636719	60.005691528320012	69.02713786347656	59.97684802294922
15	14.196	0.023042159155011177	88.499702453613281	59.993961334220516	69.033676147460938	59.96909399414063
16	15.226	-0.057191379368305206	88.509368896484375	60.004070281882422	69.027626037597656	59.978610992431641
17	16.256	0.030765749514102936	88.512100219728563	59.9933013918601563	69.0358349609375	59.983150482177734
18	17.285	0.086112096905708313	88.518100300488281	59.984481811523438	69.04222868730469	59.971881866455078
19	18.315	-0.10414708895848228	88.516181845800781	59.997970581054687	69.034095764160156	59.9702001953125
20	19.344	-0.034287728369235992	88.5077896110164	59.990089416503906	69.038200378417969	59.971920013427734
21	20.031	0.032753609120645795	88.5064697265625	59.99407958984375	69.039588928222656	59.980728148414063
22	21.060	0.0646323710680008	88.501480102539062	59.996551513671875	69.027915954589844	59.966129302978516
23	22.090	0.000642613391391933	88.503471374511719	60.015239715576172	69.01598840332031	59.985980967548228

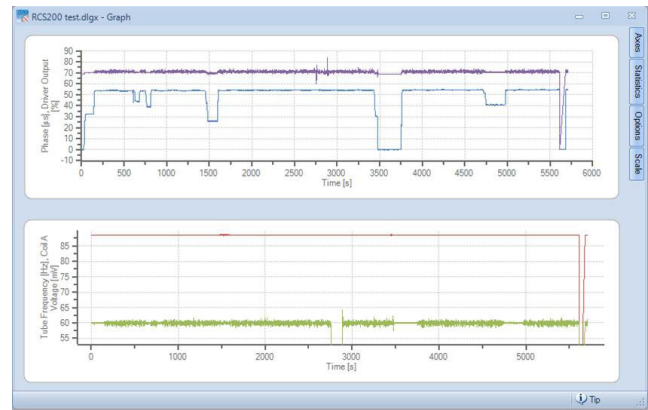

ACCESSORIES

Please consult the factory for the availability, pricing and delivery estimates of additional accessories.

SENSORS PART NUMBER CONSTRUCTION

Sensors RCS005 and RCS008 ONLY

Model	Badger Meter Coriolis Flow Meter							
	RCS							
Nominal Line and Equivalent Pipe Size								
1/4 in., 1/16 in.		005						
1/4 in., 3/32 in.		008						
Wetted Material								
316L Stainless Steel			S					
Process Connection Type								
NPT						NPT		
O-Ring, Face Sealing Body, 9/16-18 Threads						FSM		
O-Ring, Face Sealing Gland						FSF		
Electronic Mounting Options								
Remote Mount Transmitter						R		
Certifications								
General/Ordinary Area							G	
Calibration/Meter Uncertainty								
Liquids (Gases)								
Mass Flow: 0.1% (0.5%) ± 0.05% of FS zero stability; Density: ± 0.002 g/cm3								3
Reserved								
None (Reserved)								N
Specials								
Special Code (leave blank for non-custom orders)								XXX

TRANSMITTER PART NUMBER CONSTRUCTION

Model	Badger Meter Coriolis Transmitter							
	RCT							
Enclosure Type								
NEMA 4 [IP 65]		N						
Transmitter Options								
Display and Keyboard						K		
Area Classification								
General Area							D2	
Electronic Mounting Option								
Remote Mount Transmitter						R		
Communication Protocol								
Modbus RTU & Modbus TCP/IP								E
Modbus RTU (Standard on all models)								M
Sensor Connection								
Ordinary Areas								N
Specials								
3-Digit Special Code (leave blank for non-custom orders)								XXX

ООО “РусАвтоматизация”

454010 г. Челябинск, ул. Гагарина 5, оф. 507

тел. 8 800 775 09 57 (звонок бесплатный), +7(351)799 54 26, тел./факс +7(351)211 64 57

info@rusautomation.ru; русавтоматизация.пф; www.rusautomation.ru