

Incremental encoders

Blind or through hollow shaft max. $\varnothing 25.4$ mm

1024...16384 pulses per revolution



G110H, G110S



G110H with through hollow shaft

Features

- Encoder with blind or through hollow shaft max. $\varnothing 25.4$ mm
- Max. 16384 pulses per revolution
- Optical sensing
- Robust design
- High resistance to shock and vibrations
- High signal quality

Technical data - electrical ratings

| | |
|-----------------------------|---------------------------------------------------|
| Voltage supply | 5 VDC ± 10 % 4.75...30 VDC |
| Reverse polarity protection | Yes (4.75...30 VDC) |
| Consumption w/o load | ≤ 30 mA (24 VDC) ≤ 60 mA (5 VDC) |
| Pulses per revolution | 1024...16384 |
| Reference signal | Zero pulse, width 90° |
| Sensing method | Optical |
| Output frequency | ≤ 150 kHz |
| Output signals | A 90° B, N + inverted |
| Output stage | Linedriver/RS422 Push-pull short-circuit proof |
| Interference immunity | DIN EN 61000-6-2 |
| Emitted interference | DIN EN 61000-6-4 |
| Approval | UL approval / E63076 |

Technical data - mechanical design

| | |
|-------------------------|------------------------------------------------------------------------------------------|
| Size (flange) | $\varnothing 75$ mm |
| Protection DIN EN 60529 | IP 54 |
| Operating speed | ≤ 3800 rpm |
| Rotor moment of inertia | 2000 gcm ² |
| Materials | Housing: aluminium Flange: aluminium |
| Operating temperature | -25...+85 °C (24 VDC) -40...+85 °C (optional) |
| Relative humidity | 95 % non-condensing |
| Resistance | DIN EN 60068-2-6 Vibration 10 g, 16-2000 Hz DIN EN 60068-2-27 Shock 200 g, 6 ms |
| Connection | Connector M23, 12-pin |
| Weight approx. | 700 g |

G110H

| | |
|------------|------------------------------------------------------------------------------------------------------------------------------------------|
| Shaft type | $\varnothing 20$ mm (through hollow shaft) $\varnothing 25$ mm (through hollow shaft) $\varnothing 25.4$ mm (through hollow shaft) |
|------------|------------------------------------------------------------------------------------------------------------------------------------------|

G110S

| | |
|------------|--------------------------------------------------------------------------------------|
| Shaft type | $\varnothing 20$ mm (blind hollow shaft) $\varnothing 25$ mm (blind hollow shaft) |
|------------|--------------------------------------------------------------------------------------|

Incremental encoders

Blind or through hollow shaft max. $\varnothing 25.4$ mm

1024...16384 pulses per revolution

G110H, G110S

Part number

Through hollow shaft

G110H. **C3**

Pulse number - see table

Connection

C3 Connector M23, 12-pin, radial

Voltage supply / signals

22 5 VDC / linedriver RS422 (≤ 6000 pulses)
 25 5 VDC / linedriver RS422 (> 6000 pulses)
 70 4.75...30 VDC / push-pull (≤ 6000 pulses)
 75 4.75...30 VDC / push-pull (> 6000 pulses)

Through hollow shaft / torque pin

H $\varnothing 20$ mm, clamping ring on flange, without pin
 1 $\varnothing 20$ mm, clamping ring on flange, pin 15 mm
 G $\varnothing 25$ mm, clamping ring on flange, without pin
 2 $\varnothing 25$ mm, clamping ring on flange, pin 15 mm
 F $\varnothing 25$ mm, clamping ring on housing, without pin
 5 $\varnothing 25$ mm, clamping ring on housing, pin 15 mm
 0 $\varnothing 25.4$ mm, clamping ring on housing, without pin
 A $\varnothing 25.4$ mm, clamping ring on housing, pin 15 mm

Blind hollow shaft

G110S. **C3**

Pulse number - see table

Connection

C3 Connector M23, 12-pin, radial

Voltage supply / signals

22 5 VDC / linedriver RS422
 70 4.75...30 VDC / push-pull

Blind hollow shaft / torque pin

H $\varnothing 20$ mm, clamping ring on flange, without pin
 1 $\varnothing 20$ mm, clamping ring on flange, pin 15 mm
 G $\varnothing 25$ mm, clamping ring on flange, without pin
 2 $\varnothing 25$ mm, clamping ring on flange, pin 15 mm

Accessories

Connectors and cables

| | |
|-----------|------------------------------------------|
| Z 141.001 | Female connector M23, 12-pin, less cable |
| Z 141.003 | Female connector M23, 12-pin, 2 m cable |
| Z 141.005 | Female connector M23, 12-pin, 5 m |
| Z 141.007 | Female connector M23, 12-pin, 10 m cable |

Mounting accessories

| | |
|-----------|---------------------------------------------------------------------|
| Z 119.041 | Torque support by rubber buffer element for encoders with 15 mm pin |
| Z 119.043 | Spring coupling for GX and G1 |
| Z 119.050 | Spring coupling for one-side attachment, length 35 mm |

Part number (pulse number)

| | | | |
|-----------|-----------|-----------|------------|
| 23 (1024) | 30 (2500) | 35 (5000) | 73 (10000) |
| 29 (2048) | 34 (4096) | 70 (8192) | 71 (16384) |

Other pulse numbers on request.

Example: part number 35 = 5000 pulses.

Incremental encoders

Blind or through hollow shaft max. $\varnothing 25.4$ mm

1024...16384 pulses per revolution

G110H, G110S

Output signals

Clockwise rotating direction when looking at flange.

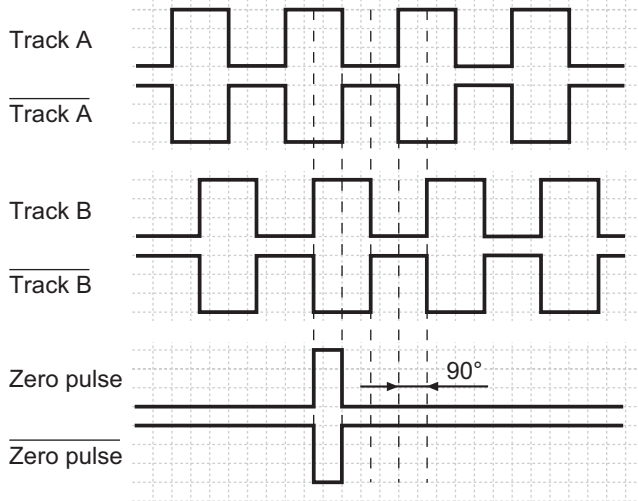

Terminal assignment

| Connector | Assignment |
|-----------|--------------------------------|
| Pin 1 | Track B inv. |
| Pin 2 | UB-Sense |
| Pin 3 | Track N (zero pulse) |
| Pin 4 | Track N inv. (zero pulse inv.) |
| Pin 5 | Track A |
| Pin 6 | Track A inv. |
| Pin 7 | – |
| Pin 8 | Track B |
| Pin 9 | – |
| Pin 10 | GND |
| Pin 11 | GND-Sense |
| Pin 12 | UB |

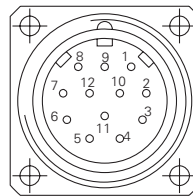

UB-Sense and GND-Sense are directly connected to UB resp. GND. Please use cores twisted in pairs (for example track A / track A inv.) for extension cables of more than 10 m length.

Trigger level

| Outputs | Linedriver RS422 |
|-------------------|---------------------|
| Output level High | >2.5 V (I = -20 mA) |
| Output level Low | <0.5 V (I = 20 mA) |
| Load High / Low | <20 mA |

| Outputs | Push-pull short-circuit proof |
|-------------------|-------------------------------|
| Output level High | >UB -3 V (I = -20 mA) |
| Output level Low | <0.5 V (I = 20 mA) |
| Load High / Low | <20 mA |

Incremental encoders

Blind or through hollow shaft max. $\varnothing 25.4$ mm
1024...16384 pulses per revolution

G110H, G110S

Dimensions

G110H - through hollow shaft, clamping ring on flange

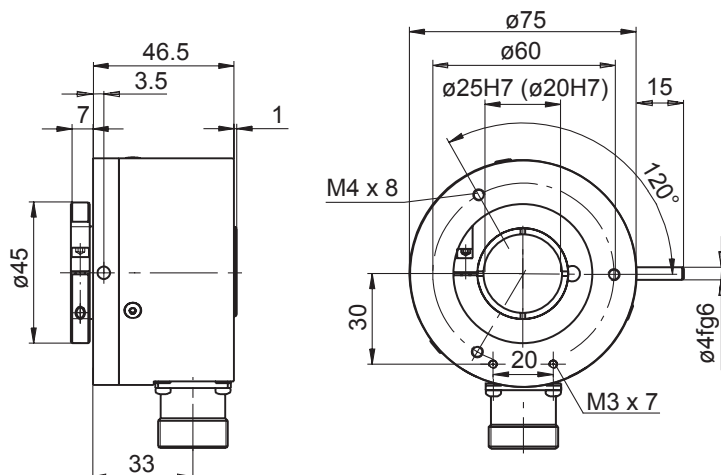

G110H - through hollow shaft, clamping ring on housing

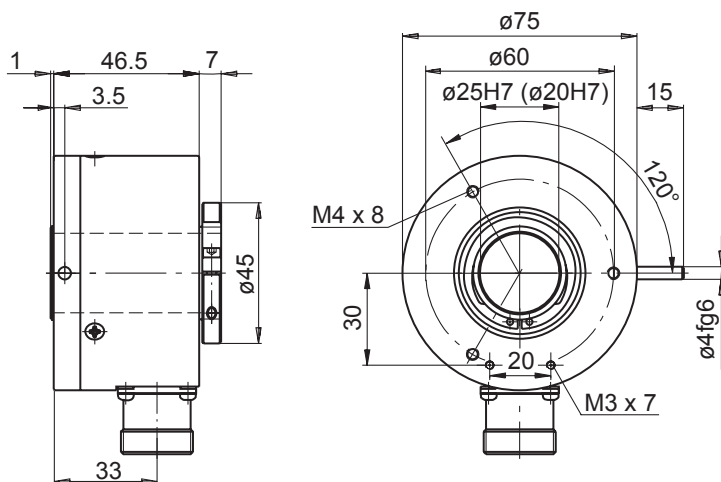

G110S - blind hollow shaft, clamping ring on flange

