

**ROTARY ENCODER (INCREMENTAL TYPE)
E88H SERIES
INSTRUCTION MANUAL**



Thank you for choosing our Autonics product.
Please read the following safety considerations before use.

■ Safety Considerations

※Please observe all safety considerations for safe and proper product operation to avoid hazards.
※⚠ symbol represents special caution due to special circumstances in which hazards may occur.

- ⚠ **Warning** Failure to follow these instructions may result in serious injury or death.
- ⚠ **Caution** Failure to follow these instructions may result in personal injury or product damage.

⚠ Warning

1. **Fall-safe device must be installed when using the unit with machinery that may cause serious injury or substantial economic loss.** (e.g. nuclear power control, medical equipment, ships, vehicles, railways, aircraft, combustion apparatus, safety equipment, crime/disaster prevention devices, etc.)
Failure to follow this instruction may result in fire, personal injury, or economic loss.
2. **Install on a device panel to use.**
Failure to follow this instruction may result in fire.
3. **Do not connect, repair, or inspect the unit while connected to a power source.**
Failure to follow this instruction may result in fire.
4. **Check 'Connections' before wiring.**
Failure to follow this instruction may result in fire.
5. **Do not disassemble or modify the unit.**
Failure to follow this instruction may result in fire.

⚠ Caution

1. **Use the unit within the rated specifications.**
Failure to follow this instruction may result in fire or product damage.
2. **Do not short the load.**
Failure to follow this instruction may result in product damage by fire.
3. **Do not use the unit in the place where flammable/explosive/corrosive gas, humidity, direct sunlight, radiant heat, vibration, impact, or salinity may be present.**
Failure to follow this instruction may result in fire or explosion.
4. **Do not use the unit near the place where there is the equipment which generates strong magnetic force or high frequency noise and strong alkaline, strong acidic exists.**
Failure to follow this instruction may result in product damage.

■ Ordering Information

E88H	30	1024	2		15
Series	Shaft diameter	Pulses/revolution	Output phase	Control output	Power supply
Ø88mm, hollow shaft type	Ø30mm	1024	2: A, B, 6: A, \bar{A} , B, \bar{B} , Z, Z	No mark : Complemental output L: Line driver output	15: 15VDC ±5% 5: 5VDC ±5%

■ Control Output Diagram

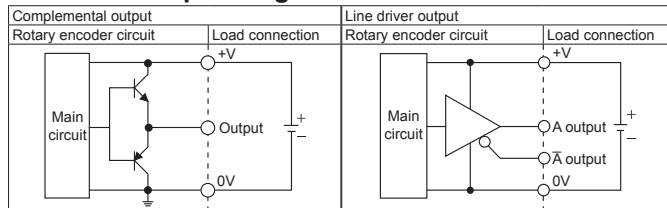

※All output circuits of A, \bar{A} , B, \bar{B} , Z, Z phase are the same.
※The above specifications are subject to change and some models may be discontinued without notice.
※Be sure to follow cautions written in the instruction manual, and the technical descriptions (catalog, homepage).

■ Specifications

Item	Hollow Shaft Type Ø88mm Incremental Rotary Encoder	
Model	E88H30-1024-2-15	E88H30-1024-6-L-5
Revolution (PPR)	1,024	
Output phase	A, B phase	
Phase difference of output	Output between A and B phase: $\frac{T}{4} \pm \frac{T}{10}$ (T=1 cycle of A phase)	
Control output	<ul style="list-style-type: none"> • [L]-Load current: max. 15mA • Residual voltage: max. 2.0VDC • [H]-Load current: max. 15mA • Output voltage: min. 10VDC 	<ul style="list-style-type: none"> • [L]-Load current: max. 20mA • Residual voltage: max. 0.5VDC • [H]-Load current: max. 20mA • Output voltage: min. 2.5VDC
Response time (rise, fall)	Max. 1µs (cable length: 8m, load resistance: 1kΩ)	Max. 0.5µs (cable length: 8m, I sink = 20mA)
Max. response frequency	150kHz	
Power supply	15VDC ±5% (ripple P-P: max. 5%)	5VDC ±5% (ripple P-P: max. 5%)
Current consumption	Max. 60mA (disconnection of the load)	Max. 50mA (disconnection of the load)
Insulation resistance	Over 100MΩ (at 500VDC megger)	
Dielectric strength	750VAC 50/60Hz for 1 min (between all terminals and case)	
Connection	Radial cable type	
Starting torque	Max. 600gf cm (0.06N m)	
Moment of inertia	Max. 800g·cm ² (8×10 ⁻⁵ kg m ²)	
Shaft loading	Radial: max. 5kgf, thrust: max. 2.5kgf	
Max. allowable revolution ^{※1}	3,600rpm	
Vibration	1.5mm amplitude at frequency of 10 to 55Hz (for 1 min) in each X, Y, Z direction for 2 hours	
Shock	Approx. max. 100G	
Environment	Ambient temp. -10 to 70°C, storage: -25 to 85°C	Ambient humi. 35 to 85%RH, storage: 35 to 90%RH
Protection structure	P50 (IEC standard)	
Cable	Ø6mm, 6-wire, 8m, shield able (AWG24, core diameter: 0.16mm, number of cores: 11, insulator out diameter: Ø1mm)	Ø6mm, 8-wire, 8m, shield cable (AWG24, core diameter: 0.08mm, number of cores: 40, insulator out diameter: Ø1mm)
Accessory	Spring bracket: 2	
Approval	CE (except line driver output model)	
Weight ^{※2}	Approx. 1.49kg (approx. 1.45kg)	

※1: Make sure that max. response revolution should be lower than or equal to max. allowable revolution when selecting the resolution.
[Max. response revolution (rpm)] = $\frac{\text{Max. response frequency}}{\text{Resolution}} \times 60 \text{ sec}$
※2: The weight includes packaging. The weight in parenthesis is for unit only.
※Environment resistance is rated at no freezing or condensation.

■ Dimensions

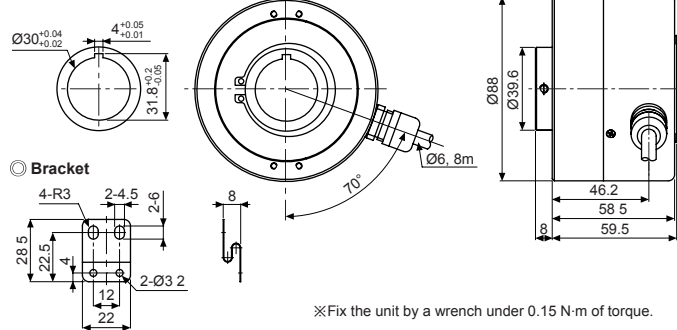

■ Bracket

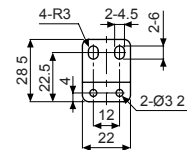

※Fix the unit by a wrench under 0.15 N·m of torque.

■ Connections

○ Complemental output

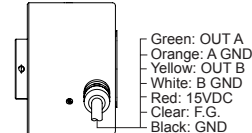

○ Line driver output

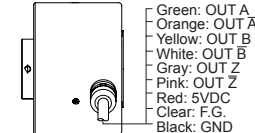

※Unused wires must be insulated.
※The metal case and shield cable of encoder should be grounded (F.G.).
※The output circuit has the dedicated IC and be sure not to short-circuit when wiring the output cables.
※Do not apply tensile strength over 30N to the cable.

■ Output Waveforms

○ Complemental output

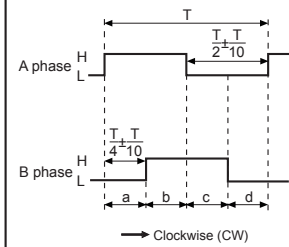

Note	Standard error
a+b+c+d	T (1 cycle of A, B phase)
a+b, c+d	$\frac{T}{2} \pm \frac{T}{10}$
a, b, c, d	$\frac{T}{4} \pm \frac{T}{10}$

○ Line driver output

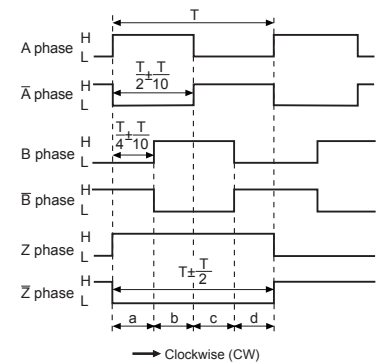

■ Cautions during Use

1. Follow instructions in 'Cautions during Use'. Otherwise, it may cause unexpected accidents.
2. 5VDC, 15VDC power supply should be insulated and limited voltage/current or Class 2, SELV power supply device.
3. For using the unit with the equipment which generates noise (switching regulator, inverter, servo motor, etc.), ground the shield wire to the F.G. terminal.
4. Ground the shield wire to the F.G. terminal.
5. When using switching mode power supply, frame ground (F.G.) terminal of power supply should be grounded.
6. Wire as short as possible and keep away from high voltage lines or power lines, to prevent inductive noise.
7. For Line driver unit, use the twisted pair wire which is attached seal and use the receiver for RS-422A communication.
8. Check the wire type and response frequency when extending wire because of distortion of waveform or residual voltage increment etc by line resistance or capacity between lines. This unit may be used in the following environments.
 - ①Indoors (in the environment condition rated in 'Specifications')
 - ②Altitude max. 2,000m
 - ③Pollution degree 2
 - ④Installation category II

■ Major Products

- Photoelectric Sensors
- Fiber Optic Sensors
- Door Sensors
- Door Side Sensors
- Area Sensors
- Proximity Sensors
- Pressure Sensors
- Rotary Encoders
- Connectors/Sockets
- Switching Mode Power Supplies
- Control Switches/Lamps/Buzzers
- I/O Terminal Blocks & Cables
- Stepper Motors/Drivers/Motion Controllers
- Graphic/Logic Panels
- Field Network Devices
- Laser Marking System (Fiber, Co., Nd: YAG)
- Laser Welding/Cutting System
- Temperature Controllers
- Temperature/Humidity Transducers
- SSRs/Power Controllers
- Counters
- Timers
- Panel Meters
- Tachometer/Pulse (Rate) Meters
- Display Units
- Sensor Controllers

ООО "РусАвтоматизация"
454010 г. Челябинск, ул. Гагарина 5, оф. 507
тел. 8 800 775 09 57 (звонок бесплатный),
тел. (351)799 54 26, тел./факс (351)211 64 57
info@rusautomation.ru; www.rusautomation.ru
rusавтоматизация рф