

⚠ Please read "Safety Considerations" in operation manual before using.



Shaft Type Ø58mm Sine Wave Incremental Rotary Encoder

■ Specifications

Item		Shaft Type Ø58mm Sine Wave Incremental Rotary Encoderz		
Model		E58S9.25-2048-10-A-5-R	E58S9.25-2048-10-A-5-S	
Revolution (PPR)		2,048		
Output phase		A, \bar{A} , B, \bar{B} , Z, \bar{Z} , C, \bar{C} , D, \bar{D} phase		
Phase difference of output		Phase difference between A and B: $\frac{T}{4} \pm \frac{T}{8}$ (T=1cycle of A phase) Phase difference between C and D: 90°		
Electrical specification	Control output	Output type	OP Amp output	
		Output current	Max. 10mA	
		Output voltage	$V_{pp} \approx 0.5V \pm 0.1V$	
		DC offset	$V_{DC}: 2.5V \pm 0.3V$	
	Max. response frequency		200kHz	
	Power supply		5VDC $\pm 5\%$ (ripple P-P: max. 5%)	
	Current consumption		Max. 120mA (disconnection of the load)	
	Insulation resistance		Over 100M Ω (at 500VDC megger between all terminals and case)	
Dielectric strength		750VAC 50/60Hz for 1 minute (between all terminals and case)		
Connection		Axial cable type	Radial cable type	
Mechanical specification	Starting torque		Max. 100gf·cm (0.0098N·m)	
	Moment of inertia		Max. 15g·cm ² (1.5×10^{-6} kg·m ²)	
	Shaft loading		Radial: 10kgf, Thrust: 2.5kgf	
	Max. allowable revolution		6,000rpm	
Shaft		Taper shaft Ø9.25mm, Taper 1:10		
Vibration		1.5mm amplitude at frequency of 10 to 55Hz in each X, Y, Z direction for 2 hours		
Shock		Approx. max. 100G		
Environment	Ambient temp.	-20 to 100°C, storage: -25 to 100°C		
	Ambient humi.	35 to 85%RH, storage: 35 to 90%RH		
Protection structure		IP50 (IEC standard)		
Cable		Ø6mm, 17-wire, 9m ^{※1} , Shield cable (AWG28, core diameter: 0.08mm, number of cores: 17, insulator out diameter: Ø0.8mm)		
Accessory		M5×0.8 (50L), M5×0.8 (47L) wrench bolt		
Approval		CE		
Weight ^{※2}		Approx. 1.02kg (approx. 930g)		

※1: Option is 7m, 15m.

※2: The weight includes packaging. The weight in parenthesis in for unit only.

※Environment resistance is rated at no freezing or condensation.

E58 Series

Control Output Diagram

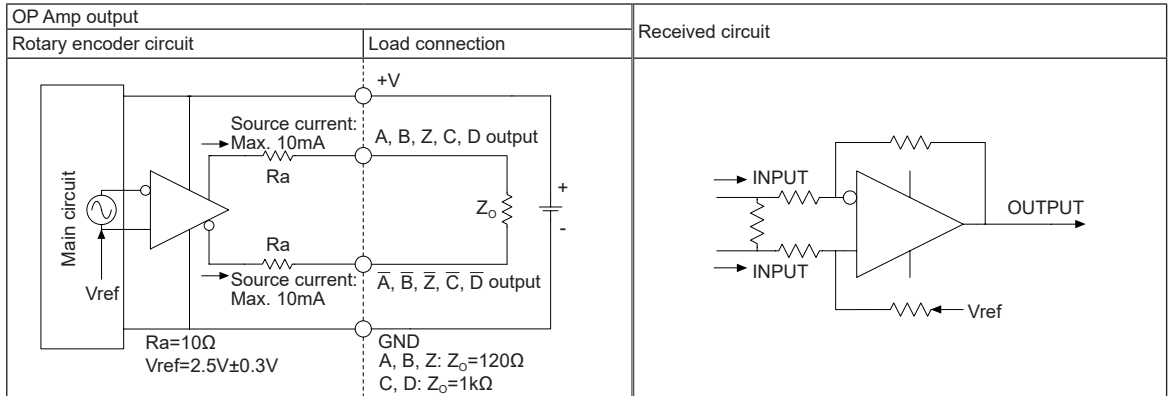

• All output circuits of A, \bar{A} , B, \bar{B} , Z, \bar{Z} , C, \bar{C} , D, \bar{D} phase are the same.

Output Waveforms

○ A, \bar{A} , B, \bar{B} , Z, \bar{Z} phase

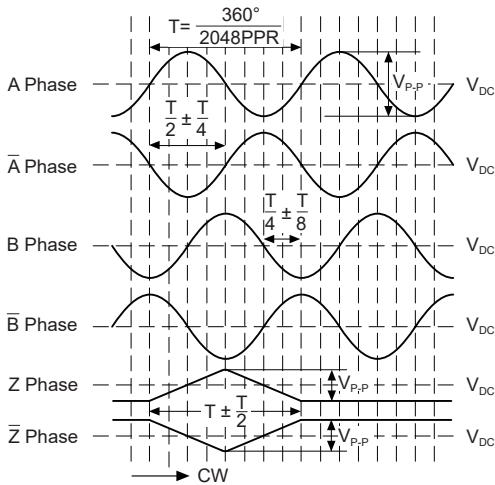

○ C, \bar{C} , D, \bar{D} phase

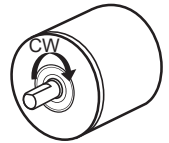
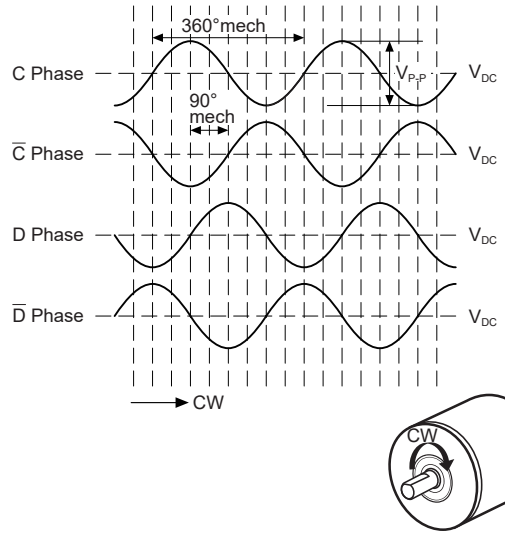

Connections

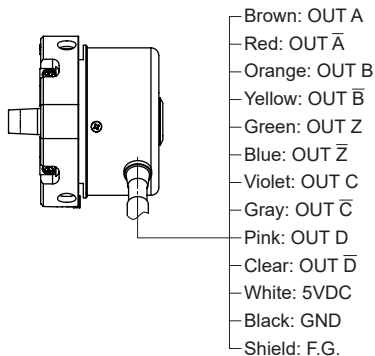

※ Unused wires must be insulated.

※ The metal case and shield cable of encoder should be grounded (F.G.).

※ The output circuit has the dedicated IC and be sure not to short-circuit when wiring the output cables.

Incremental Sine Wave Ø58mm Shaft Type

■ Dimensions

(unit: mm)

○ Axial cable type

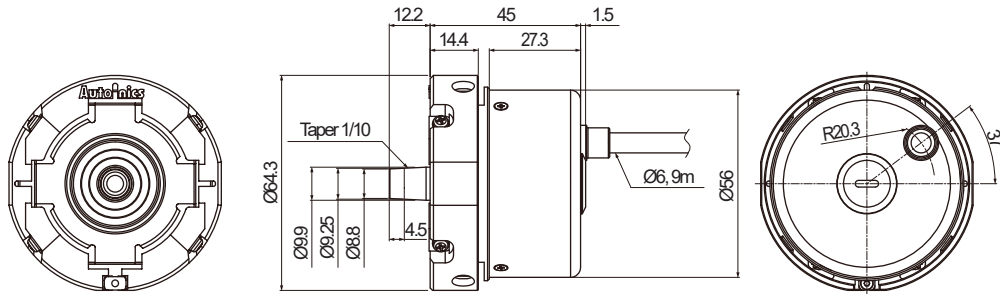

○ Radial cable type

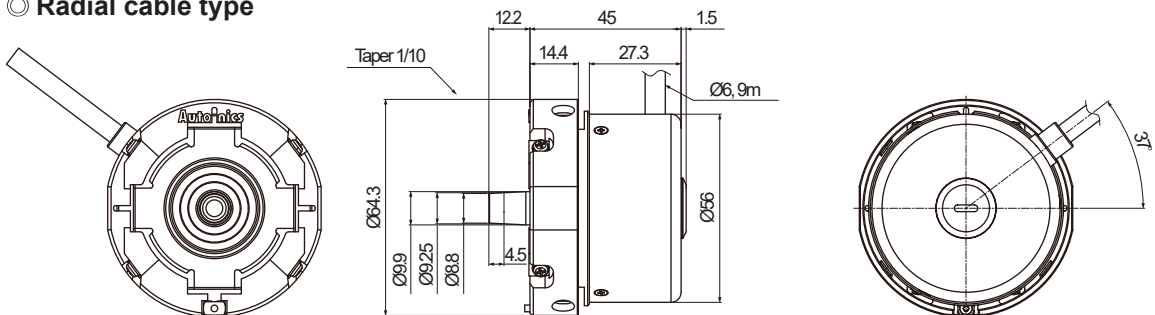

■ Installation

(unit: mm)

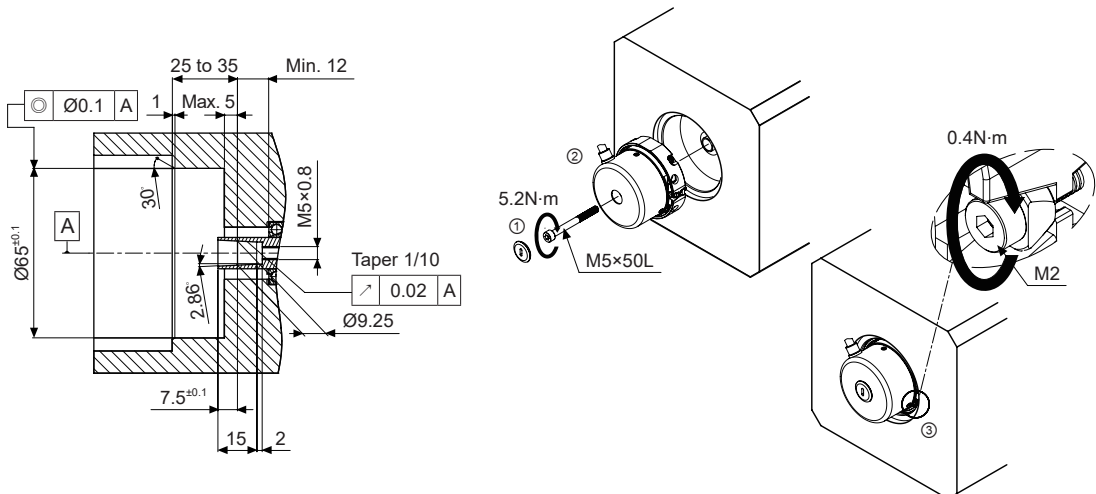

- ① Insert the M5×50L wrench bolt at rear of the E58S .
- ② Install the E58S on the device.
- ③ Adjust bracket size with M2 wrench.

ООО "РусАвтоматизация"

454010 г. Челябинск, ул. Гагарина 5, оф. 507
 тел. 8-800-775-09-57 (звонок бесплатный), +7(351)799-54-26, тел./факс +7(351)211-64-57
info@rusautomation.ru; rusавтоматизация.рф; www.rusautomation.ru