

Compact Oil Proof Type Photoelectric Sensor

■ Features

- Strengthened oil proof (optimized for automobile and machine tool industry)
- High performance lens with long sensing distance
 - Through-beam type: 15m
 - Diffuse reflective type: 1m
 - Polarized retroreflective type: 3m (MS-2S)
- M.S.R. (Mirror Surface Rejection) function (polarized retroreflective type)
- Compact size: W20 × H32 × L11mm
- IP67 protection structure (IEC standard), IP67F oil proof protection structure (JEM standard)
- Light ON/Dark ON operation mode switch
- Sensitivity adjuster
- Built-in reverse polarity protection circuit and output short overcurrent protection circuit
- Mutual interference prevention function (except through-beam type)
- Excellent noise immunity and minimal influence from ambient light



※The model name with '-C' is connector type, and with '-W' is cable connector type.
 ※MST-□ is sold separately.

 Please read "Safety Considerations" in instruction manual before using. 

■ Specifications

| Model | NPN open collector output | BJR15M-TDT-□-F | BJR10M-TDT-□-F | BJR3M-PDT-□-F | BJR1M-DDT-□-F | BJR100-DDT-□-F |
|------------------------|--|--|------------------|---|-------------------------------|------------------|
| | PNP open collector output | BJR15M-TDT-□-P-F | BJR10M-TDT-□-P-F | BJR3M-PDT-□-P-F | BJR1M-DDT-□-P-F | BJR100-DDT-□-P-F |
| Sensing type | Through-beam type | | | Retroreflective type (built-in polarizing filter) | Diffuse reflective type | |
| Sensing distance | 15m | 10m | 3m ^{*1} | 1m ^{*2} | 100mm ^{*3} | |
| Sensing target | Opaque material over Ø12mm | | | Opaque material over Ø75mm | Translucent, opaque materials | |
| Hysteresis | — | | | Max. 20% at sensing distance | | |
| Response time | Max. 1ms | | | | | |
| Power supply | 10-30VDC ⁻⁻⁻ ±10% (ripple P-P: max. 10%) | | | | | |
| Current consumption | Emitter/Receiver: max. 20mA | | | Max. 30mA | | |
| Light source | Infrared LED (850nm) | Red LED (660nm) | Red LED (660nm) | Infrared LED (850nm) | | |
| Sensitivity adjustment | Sensitivity adjuster | | | | | |
| Operation mode | Light ON / Dark ON selectable by switch | | | | | |
| Control output | NPN or PNP open collector output • Load voltage: Max. 30VDC ⁻⁻⁻ • Load current: Max. 100mA • Residual voltage - NPN: Max. 1VDC ⁻⁻⁻ , PNP: Max. 2VDC | | | | | |
| Protection circuit | Power reverse polarity protection circuit, output short over current protection circuit | | | Power reverse polarity protection circuit, output short over current protection circuit, interference prevention function | | |
| Indicator | Operation indicator: yellow LED, stability indicator: green LED (emitter's power indicator: red LED) | | | | | |
| Connection | Cable type, Connector type, Cable connector type | | | | | |
| Insulation resistance | Over 20MΩ (at 500VDC megger) | | | | | |
| Noise immunity | ±240V the square wave noise (pulse width: 1μs) by the noise simulator | | | | | |
| Dielectric strength | 1,000VAC 50/60Hz for 1 minute | | | | | |
| Vibration | 1.5mm amplitude at frequency of 10 to 55Hz (for 1 min) in each X, Y, Z direction for 2 hours | | | | | |
| Shock | 500m/s ² (approx. 50G) in each X, Y, Z direction for 3 times | | | | | |
| Environment | Ambient illu. | Sunlight: max. 11,000lx, incandescent lamp: max. 3,000lx (receiver illumination) | | | | |
| | Ambient temp. | -25 to 60°C, storage: -40 to 70°C | | | | |
| | Ambient humi. | 35 to 85%RH, storage: 35 to 85%RH | | | | |
| Protection structure | IP67 (IEC standard), IP67F (JEM standard) | | | | | |
| Material | Case: acrylonitrile-butadiene-styrene, LED Cap: polyamide 12, lens cover: polymethyl methacrylate | | | | | |

※1: The sensing distance is specified with using the MS-2S reflector. The distance between the sensor and the reflector should be set over 0.1m. When using reflective tapes, the reflectivity will vary by the size of the tape. Please refer to the catalog or web site.

※2: Non-glossy white paper 300×300mm.

※3: Non-glossy white paper 100×100mm.

※The temperature or humidity mentioned in Environment indicates a non freezing or condensation.

Compact Oil Proof Type

| | | | | | | |
|----------------------|------------------------------------|--|-------------------------|---|----------------------------|-------------------------|
| Model | NPN open collector output | BJR15M-TDT-□-F | BJR10M-TDT-□-F | BJR3M-PDT-□-F | BJR1M-DDT-□-F | BJR100-DDT-□-F |
| | PNP open collector output | BJR15M-TDT-□-P-F | BJR10M-TDT-□-P-F | BJR3M-PDT-□-P-F | BJR1M-DDT-□-P-F | BJR100-DDT-□-P-F |
| Cable | Cable type | Ø4mm, 3-wire, 2m (emitter of through-beam type: Ø4mm, 2-wire, 2m) (AWG26, core diameter: 0.1mm, number of cores: 20, insulator out diameter: Ø1mm) | | | | |
| | Connector type ^{※4} | M8 connector | | | | |
| | Cable connector type ^{※5} | Ø4mm, 3-wire, 300mm (emitter of through-beam type: Ø4mm, 2-wire, 300mm), M12 connector (AWG26, core diameter: 0.1mm, number of cores: 20, insulator out diameter: Ø1mm) | | | | |
| Accessory | Common | Mounting bracket ^{※6} , M3 bolt: 4, adjustment screwdriver | | Mounting bracket ^{※6} , M3 bolt: 2, adjustment screwdriver | | |
| | Individual | — | | Reflector (MS-2S) | — | |
| Approval | CE | | | | | |
| Weight ^{※7} | Cable type | Approx. 145g (approx. 95g) | | Approx. 115g (approx. 50g) | Approx. 100g (approx. 50g) | |
| | Connector type | Approx. 65g (approx. 12g) | | Approx. 75g (approx. 6g) | Approx. 60g (approx. 6g) | |
| | Cable connector type | Approx. 105g (approx. 55g) | | Approx. 95g (approx. 30g) | Approx. 80g (approx. 30g) | |

※4: M8 connector cable is sold separately. (AWG26, core diameter: 0.1mm, number of cores: 20, insulator out diameter: Ø1mm)

※5: M12 connector cable is sold separately. (AWG22, core diameter: 0.08mm, number of cores: 60, insulator out diameter: Ø1.65mm)

※6: Cable type and cable connector type includes bracket A and connector type includes bracket B.

※7: The weight includes packaging. The weight in parenthesis is for unit only.

■ Feature Data

◎ Through-beam type

● BJR15M-TDT-(C)-(P)-F

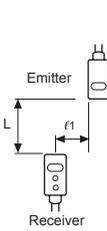
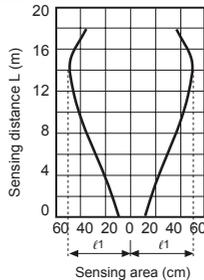
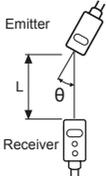
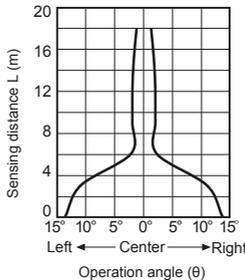
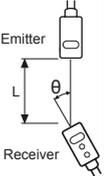
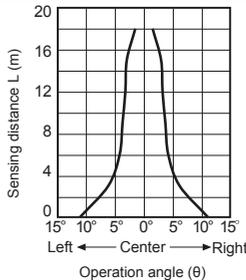
| Parallel shifting characteristic | | Emitter angle characteristic | | Receiver angle characteristic | |
|---|---|---|---|---|---|
| Measuring method | Data | Measuring method | Data | Measuring method | Data |
|  |  |  |  |  |  |

● BJR10M-TDT-(C)-(P)-F

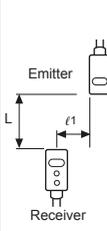
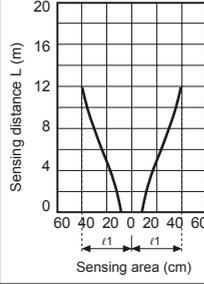
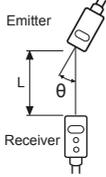
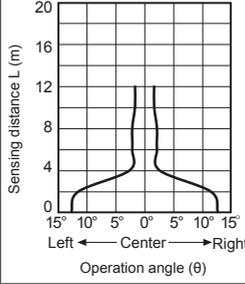
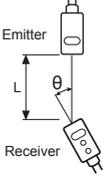
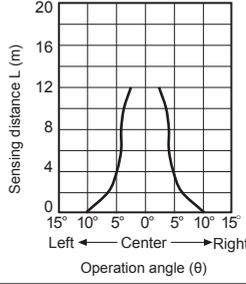
| Parallel shifting characteristic | | Emitter angle characteristic | | Receiver angle characteristic | |
|---|---|---|---|---|---|
| Measuring method | Data | Measuring method | Data | Measuring method | Data |
|  |  |  |  |  |  |

BJR-F Series

◎ Retroreflective type

● BJ3M-PDT-(C)-(P)

| Parallel shifting characteristic | | Sensor angle characteristic | | Reflector angle characteristic | |
|----------------------------------|------|-----------------------------|------|--------------------------------|------|
| Measuring method | Data | Measuring method | Data | Measuring method | Data |
| | | | | | |

◎ Diffuse/Narrow beam reflective type

● BJR1M-DDT-(C)-(P)-F

| Sensing area characteristic | | Sensing area characteristic | |
|-----------------------------|------|-----------------------------|------|
| Measuring method | Data | Measuring method | Data |
| | | | |

■ Control Output Diagram

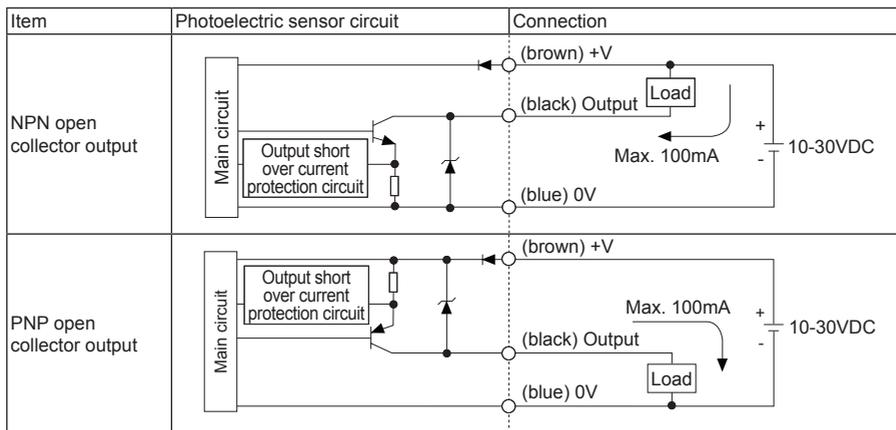

※If short-circuit the control output terminal or supply current over the rated specification, normal control signal is not output due to the output short over current protection circuit.

Compact Oil Proof Type

■ Connections

◎ Cable type

● Through-beam type

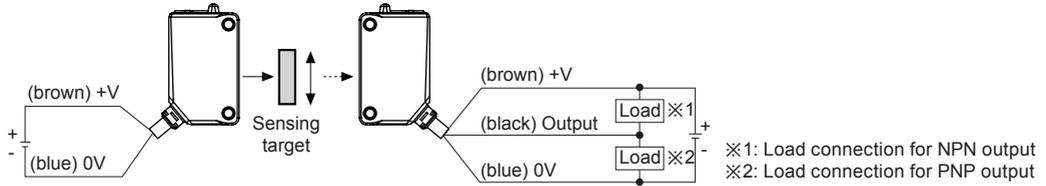

● Retroreflective type

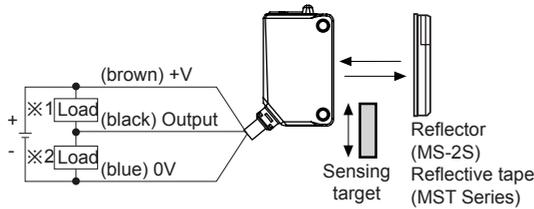

● Diffuse reflective type

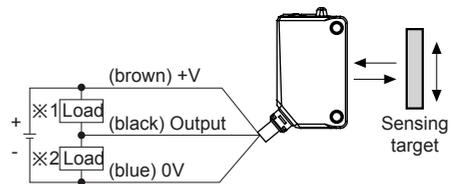

◎ Connections for connector part

● Connector type

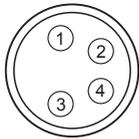

[M8 connector pin]

| Connections for cable connector part | | | |
|--------------------------------------|--------------|-------------------|---|
| Connector pin No. | Cable colors | Functions | Etc. |
| ① | Brown | Power Source (+V) | Connector cable (sold separately) • CIDH408-□ • CLDH408-□ |
| ② | White | N-C | |
| ③ | Blue | Power Source (0V) | |
| ④ | Black | Output | |

※Connector pin ② is N-C (Not Connected) terminal.

● Cable connector type

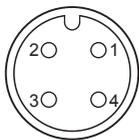

[M12 connector pin]

| Connections for cable connector part | | | |
|--------------------------------------|--------------|-------------------|---|
| Connector pin No. | Cable colors | Functions | Etc. |
| ① | Brown | Power Source (+V) | Connector cable (sold separately) • CIDH4-□ • CLDH4-□ |
| ② | White | N-C | |
| ③ | Blue | Power Source (0V) | |
| ④ | Black | Output | |

※Connector pin ② is N-C (Not Connected) terminal.

BJR-F Series

(unit: mm)

■ Dimensions

◎ Cable type

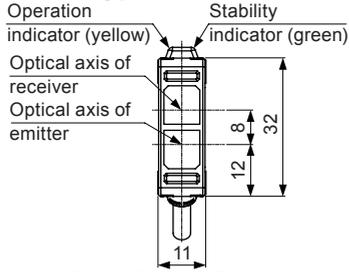

[Retroreflective/Diffuse type]

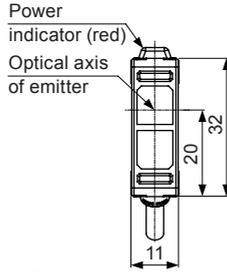

[Through-beam type (emitter)]

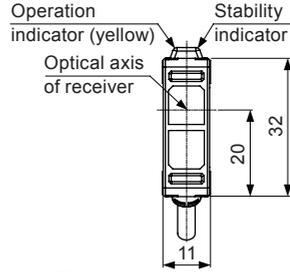

[Through-beam type (receiver)]

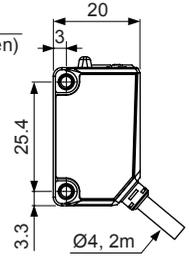

◎ Cable connector type

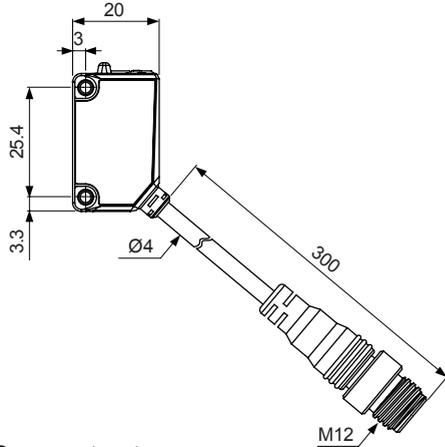

● Bracket A

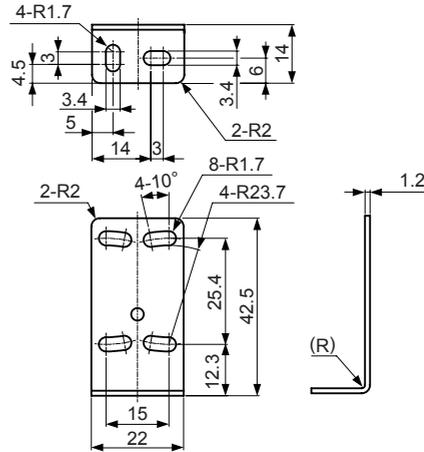

◎ Connector type

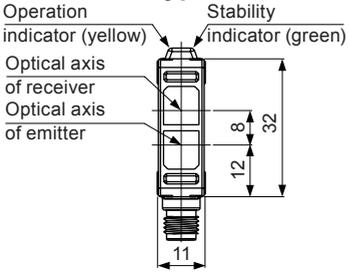

[Retroreflective/Diffuse type]

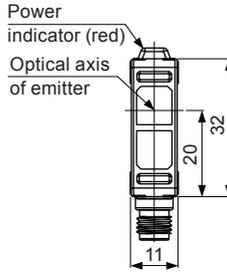

[Through-beam type (emitter)]

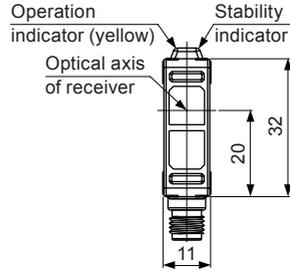

[Through-beam type (receiver)]

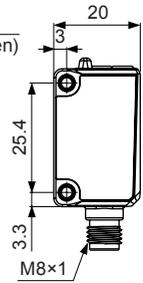

● Bracket B

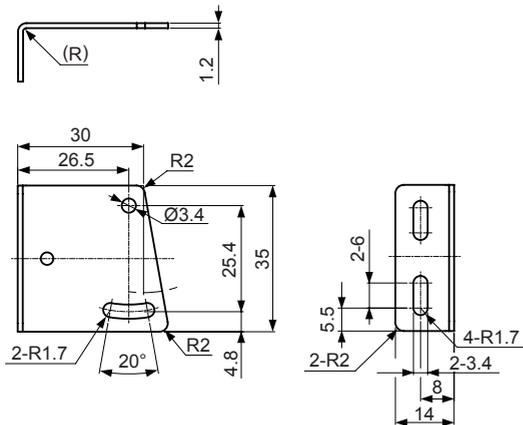

● Reflector (MS-2S)

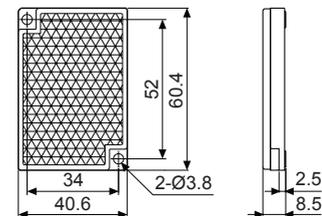

● Reflective tape (sold separately)

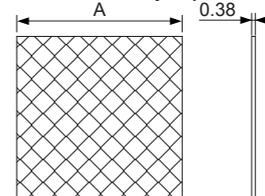

| Model | A |
|-----------|------|
| MST-50-10 | □50 |
| MST-100-5 | □100 |
| MST-200-2 | □200 |

Compact Oil Proof Type

■ Operation Mode

| Operation mode | Light ON | Dark ON |
|-------------------------------|-------------------------------------|-------------------------------------|
| Receiver operation | Received light Interrupted light | Received light Interrupted light |
| Operation indicator (red LED) | ON OFF | ON OFF |
| Transistor output (NPN/PNP) | ON OFF | ON OFF |

■ Operation Timing Diagram

◎ Through-beam type

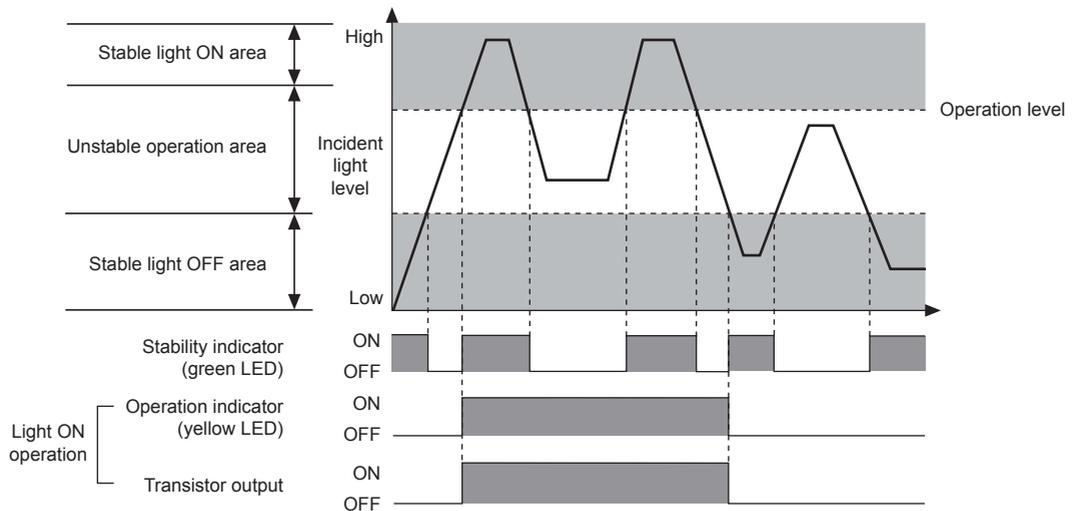

◎ Retroreflective type/Diffuse reflective type

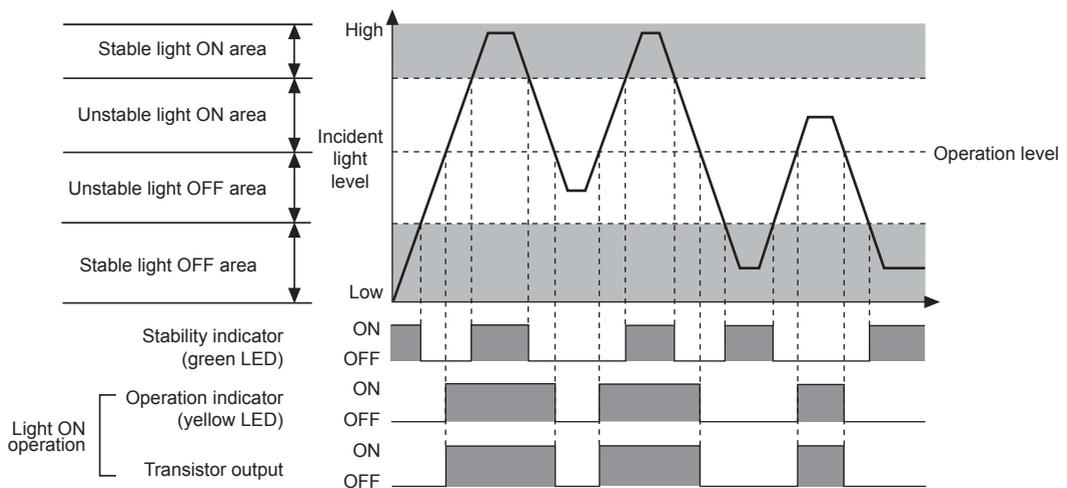

※The waveforms of 'Operation indicator' and 'Transistor output' are for Light ON operation. The waveforms are reversed for Dark ON operation.

BJR-F Series

Installation and Adjustment

For mounting

When using the reflective type photoelectric sensors closely over three units, it may result in malfunction due to mutual interference. When using the through-beam type photoelectric sensors closely over two units, it may result in malfunction due to mutual interference.

When installing the product, tighten the screw with a tightening torque of 0.5 N·m.

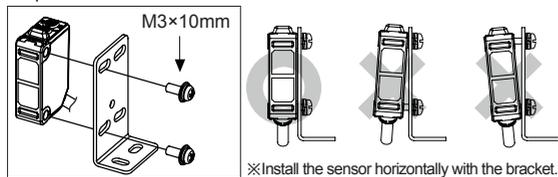

Optical axis adjustment

Through-beam type

- Place the emitter and the receiver facing each other and supply the power.
- After adjusting the position of the emitter and the receiver and check their stable indicating range, mount them in the middle of the range.
- After mounting this unit, check the operation of the sensor and lighting of the stability indicator in both status. (none or sensing target status)

※If the sensing target is translucent body or smaller than $\varnothing 15\text{mm}$, it may not sense the target because light is passed.

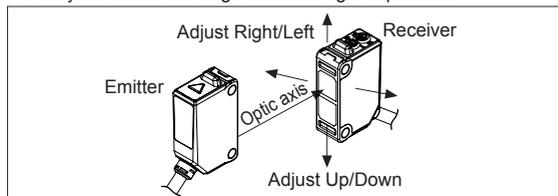

Retroreflective type

- Place the sensor and the reflector (or reflective tape) facing each other and supply the power.
- After adjusting the position of the sensor and reflector (or reflective tape) and checking their stable indicating range, mount them in the middle of the range. (none or sensing target status)
- After mounting this unit, check the operation of the sensor and in both status. (none or sensing target status)

※Please use reflective tape (MST Series) for where a reflector is not installed.

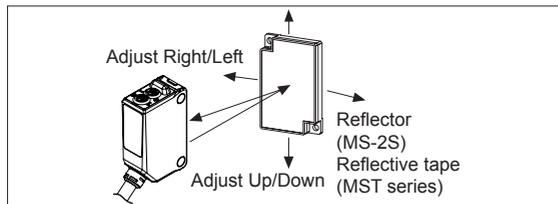

Diffuse reflective type

- Place the emitter and the receiver facing each other and supply the power.
- After adjusting the position of the emitter and the receiver and check their stable indicating range, mount them in the middle of the range.
- After mounting this unit, check the operation of the sensor and lighting of the stability indicator in both status. (none or sensing target status)

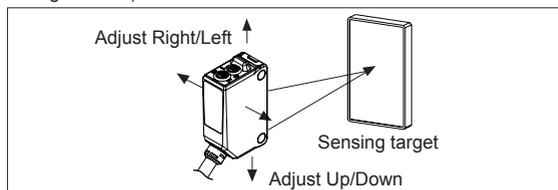

Operation mode switching

| | | |
|----------|--|--|
| Light ON | | Turn the switch all the way to the right (towards L) to select Light ON operation. |
| Dark ON | | Turn the switch all the way to the left (towards D) to select Dark ON operation. |

※For through-beam type, the switch is built-in the receiver.

Sensitivity adjustment

| Order | Sensitivity setting | Descriptions |
|-------|---------------------|--|
| 1 | | From Light ON status, turn the sensitivity setting adjuster slowly to the right from MIN sensitivity and check the position where operation indicator turns on (A). |
| 2 | | From Dark ON status, turn the sensitivity setting adjuster further right and check the position where the operation indicator turns on (B). Turn the adjuster left and check the position where the operation indicator turns off (C). ※If the operation indicator does not turn on at MAX sensitivity, the maximum sensitivity setting is set at position (C). |
| 3 | | Set the adjuster at the center position between (A) and (C) for optimal sensitivity. Also, check if the stability indicator turns off with or without the sensing target. If it does not turn off, please review the operation mode again, as sensitivity may be unstable. |

| | Light ON | Dark ON |
|-------------------------|----------|---------|
| Through-beam type | | |
| Retro-reflective type | | |
| Diffuse reflective type | | |

※Please set the sensitivity setting adjuster is executed in stable Light ON area and the reliability of environment (temperature, supply, dust etc.) is increased after the mounting it in a stable area.

※When adjusting sensitivity or switching operation modes, please use the Autonics adjustment screwdriver (included accessory).

Using a screwdriver with a bigger diameter than the adjuster buttons may cause errors when making adjustments.

※ It may cause breakdown when the sensitivity setting adjuster or the operation mode selection switch is turned by force.

Reflectivity by Reflective Tape Model

| | |
|----------------------|-----|
| MST-50-10(50×50mm) | 35% |
| MST-100-5(100×100mm) | 45% |
| MST-200-2(200×200mm) | 55% |

※ This reflectivity is based on the reflector (MS-2S).

※ Reflectivity may vary depending on usage environment and installation conditions.

The sensing distance and minimum sensing target size increase as the size of the tape increases.

Please check the reflectivity before using reflective tapes.

※ For using reflective tape, installation distance should be min. 20mm.