

## Laser Displacement Sensor

### ▣ Features

- Easy maintenance with separable structure of sensor head/amplifier unit
- Maximum resolution: 1 $\mu$ m (different by models)
- Stable measurement regardless of color or material of the object
- Mutual connection up to 8 amplifier units
  - : Interference prevention and channel alignment are automatically applied
- Various calculation function (add, subtraction, average)
- Various filter function for stable measurement (average, differential, median)
- Teaching modes configuration (1-point, 2-point) for user environment
- Mounting on DIN-Rail or wall (accessory bracket is needed) is available
- Sensor head IP67 protection structure (patented)
  - : Korea patent application number 2017-0043925



Sensor head



Amplifier unit

 Please read "Safety Considerations" in the instruction manual before using.



### ▣ Manuals

For the detail information and instructions, please refer to user manual for communication, and be sure to follow cautions written in the technical descriptions (catalog, website).  
Visit our website ([www.autonics.com](http://www.autonics.com)) to download manuals.

### ▣ Model

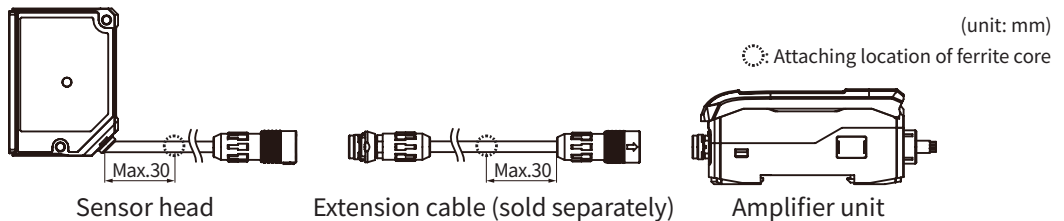

### ◎ Sensor head

Model	Beam shape	Reference distance (Maximum measurement range)	Spot diameter		
			Near	Reference	Far
BD-030	Standard	30mm (20-40mm)	Approx. 290×790 $\mu$ m (at 25mm)	Approx. 240×660 $\mu$ m (at 30mm)	Approx. 190×450 $\mu$ m (at 35mm)
BD-065	Standard	65mm (50-80mm)	Approx. 360×1590 $\mu$ m (at 55mm)	Approx. 290×1180 $\mu$ m (at 65mm)	Approx. 210×830 $\mu$ m (at 75mm)
BD-100	Standard	100mm (70-130mm)	Approx. 480×1870 $\mu$ m (at 80mm)	Approx. 410×1330 $\mu$ m (at 100mm)	Approx. 330×950 $\mu$ m (at 120mm)

### ◎ Amplifier unit



Model	Compatible sensor head
BD-A1	BD series sensor head: 1

### ◎ Extension cable (sold separately)

Model	Length
CID6P-1-SI-BD	1m
CID6P-2-SI-BD	2m
CID6P-5-SI-BD	5m
CID6P-10-SI-BD	10m

# Laser Displacement Sensor

## ■ Specifications

Sensor Head										
Model	BD-030			BD-065			BD-100			
Spot diameter (unit: $\mu\text{m}$ )	Near (25mm)	Reference (30mm)	Far (35mm)	Near (55mm)	Reference (65mm)	Far (75mm)	Near (80mm)	Reference (100mm)	Far (120mm)	
		Approx. 290×790	Approx. 240×660	Approx. 190×450	Approx. 360×1590	Approx. 290×1180	Approx. 210×830	Approx. 480×1870	Approx. 410×1330	Approx. 330×950
Resolution <sup>※1</sup>	1 $\mu\text{m}$			2 $\mu\text{m}$			4 $\mu\text{m}$			
Reference distance	30mm			65mm			100mm			
Maximum measurement range	20-40mm			50-80mm			70-130mm			
Linearity <sup>※1※2</sup>	0.1% F.S. (in 25 to 35mm)			0.1% F.S. (in 55 to 75mm)			0.15% F.S. (in 80 to 120mm)			
Temperature Characteristics <sup>※3</sup>	0.05% F.S./°C			0.06% F.S./°C						
Power supply <sup>※4</sup>	-									
Light Source	Red semiconductor laser (wavelength: 660nm, IEC 60825-1:2014)									
	Optical method	Diffuse reflection								
	Laser class	Class 1 (IEC/EN), Class I (FDA(CDRH) CFR Part 1002)			Class 2 (IEC/EN), Class II (FDA(CDRH) CFR Part 1002)					
	Output	Max. 300 $\mu\text{W}$			Max. 1mW					
Operation indicators	Power indicator: red LED, Laser emission indicator: green LED, NEAR/FAR indicator: green LED									
Connection	Connector type									
Insulation resistance	Over 20M $\Omega$ (at 500VDC= megger)									
Noise immunity	Square shaped noise by noise simulator (pulse width: 1 $\mu\text{s}$ ) $\pm$ 500V									
Dielectric strength	1,000VAC 50/60Hz for 1 minute									
Vibration	1.5mm amplitude at frequency of 10 to 55Hz (for 1 min) in each X, Y, Z direction for 2 hours									
Shock	300m/s <sup>2</sup> (Approx. 30G) in each X, Y, Z direction for 3 times									
Environment	Ambient illumination	Max. Incandescent lamp 10,000lx								
	Ambient temperature	-10 to 50°C, storage: -15 to 60°C								
	Ambient humidity	Under 85%RH, storage: under 85%RH								
Protection structure	IP67 (IEC Standards, except connector of extension cable)									
Material	Case: Polycarbonate, Sensing part: Glass, Cable: Polyvinyl chloride									
Amplifier unit compatibility	BD Series amplifier unit: 1									
Accessory	Ferrite core (made by TDK co. ZCAT2132-1130), Mounting bracket, Bolt, Nut									
Approval	 									
Weight <sup>※5</sup>	Approx. 209g (approx. 56g)			Approx. 233g (approx. 68g)			Approx. 233g (approx. 68g)			

※1: When measuring fixed non-glossy white paper (reference temperature: 25°C, reference distance, response time: 1ms, average 128 times).

※2: Value indicates the error with respect to the ideal straight line and the numbers in parentheses are the rated measurement ranges guarantee linearity.

※3: Value measured by using an aluminum jig fix the sensor head and non-glossy white paper.

※4: Using power from the amplifier unit.

※5: The weight is with packaging and the weight in parenthesis is only unit weight.

※The temperature or humidity mentioned in Environment indicates a non freezing or condensation environment.

## ■ Specifications

Amplifier unit		
Model	BD-A1	
Power supply	10-30VDC $\pm$ 10% (When connecting BD-C Series communication converter, 12-30VDC $\pm$ )	
Power consumption <sup>※1</sup>	Max. 2800mW (30VDC $\pm$ )	
Control input <sup>※2</sup>	Timing	No-voltage input
	Output reset	
	Laser OFF	
	Zero adjustment	
	Bank change	
Judgment output (HIGH/GO/LOW)	NPN or PNP open collector output (Load current: Max. 100mA)	
Alarm output	NPN or PNP open collector output (Load current: Max. 100mA)	
Analog output <sup>※3</sup>	Voltage	-5-5V, 0-5V, 1-5V (Resistance: 100 $\Omega$ , $\pm$ 0.05% F.S., at 10V)
	Current	4-20mA (Max load resistance: 350 $\Omega$ , $\pm$ 0.2% F.S., at 16mA)
Residual voltage	NPN: Max. 1.5V, PNP: Max. 2.5V	
Protection circuit	Reverse polarity protection circuit, output overcurrent (short-circuit) protection circuit	
Response time	0.33, 0.5, 1, 2, 5 ms (5-step adjustment)	
Min. display unit	1 $\mu$ m	
Display method	Dual display by 6-digit, 11-segment LED	
Display range <sup>※4</sup>	$\pm$ 99.999mm to $\pm$ 99mm (4-step adjustment)	
Display period	Approx. 100ms	
Insulation resistance	Over 20M $\Omega$ (at 500VDC $\pm$ megger)	
Noise immunity	Square shaped noise by noise simulator (pulse width: 1 $\mu$ s) $\pm$ 500V	
Dielectric strength	1,000VAC 50/60Hz for 1 minute	
Vibration	1.5mm amplitude at frequency of 10 to 55Hz (for 1 min) in each X, Y, Z direction for 2 hours	
Shock	300m/s <sup>2</sup> (Approx. 30G) in each X, Y, Z direction for 3 times	
Environment	Ambient temperature	-10 to 50°C, storage: -15 to 60°C
	Ambient humidity	Under 85%RH, Storage: under 85%RH
Protection structure	IP40 (IEC Standards)	
Material	Case: Polycarbonate, Cover: Polycarbonate, Cable: Polyvinyl chloride	
Connection	Connector type	
Sensor head compatibility	BD Series sensor head: 1	
Accessory	Mounting bracket, Side connector	
Approval	CE  US	
Weight <sup>※5</sup>	Approx. 228g (approx. 126g)	

※1: Power to the load is not included.

※2: Use after assigning to external input line. For the details, refer to the item in '■ Parameter group'.

※3: It is possible to use among -5-5V, 0-5V, 1-5V, 4-20mA by parameter setting.

※4: Setting range is assigned automatically when connecting sensor head.

※5: The weight is with packaging and the weight in parenthesis is only unit weight.

※The temperature or humidity mentioned in Environment indicates a non freezing or condensation environment.

# Laser Displacement Sensor

## ■ Unit Description

### ◎ Sensor head

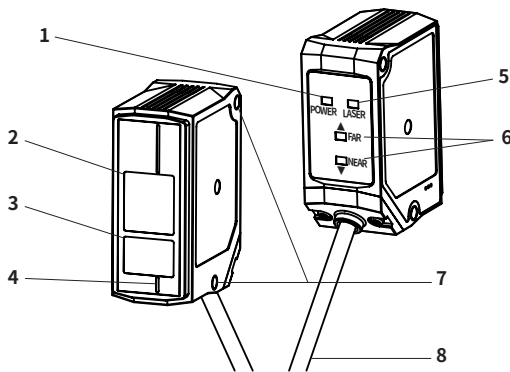

- 1 Power indicator (red)**  
Indicates whether power supply the sensor head.
- 2 Receiver**  
Receives reflected laser from the object.
- 3 Emitter**  
Emits laser to the object to measure the displacement.
- 4 Emission center line**  
The line and the object should be aligned because the laser is emitted along the line.
- 5 Laser emission indicator (green)**  
Lights ON during sensor head emits laser.
- 6 NEAR/FAR indicator (green)**  
Out of the rated measurement range: Flashing  
Near the reference distance: Turns ON.
- 7 Mounting hole**
- 8 Connector cable**

### ◎ Amplifier unit

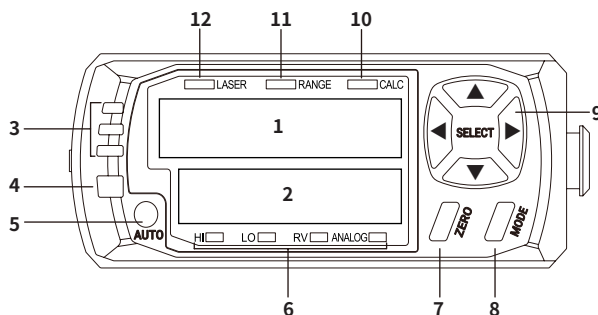

- 1 Present value (PV) display: Red**  
Displays PV, calculating result (when using calculation), parameter name (when setting parameter).
- 2 Setting value (SV) display: Green**  
Displays SV (HIGH, LOW, RV, Analog output, Bank), parameter setting value (when setting parameter). The type of displaying SV can be recognized by Setting value (SV) indicator recognition .
- 3 Judgment indicator: Red (HI/LO), Green (GO)**  
Lights ON when outputting judgment value following to SV.
- 4 Alarm indicator: Red**  
Lights ON when outputting alarm.
- 5 Optimization setting key [AUTO]**  
Executes Sensing optimization .
- 6 Setting value (SV) indicator recognition lamp: Green**  
Displays the value type of Setting value (SV) display  
HI/LOW: HIGH/LOW judgment value  
RV: Real distance value  
ANALOG: Analog output
- 7 Zero adjustment setting key [ZERO]**  
Executes Zero adjustment .
- 8 Mode setting key [MODE]**  
Enters modes and sets the parameter value.
- 9 Direction key [◀/▶/▲/▼]**  
Sets the value of mode and parameter.
- 10 Calculation indicator (CALC): Green**  
Lights ON when using calculation.
- 11 Measurement range indicator (RANGE): Green**  
Lights ON when PV is in the measurement range, lights OFF when PV is out of the measurement range or emitting laser is stopped.
- 12 Laser emission indicator (LASER): Green**  
Lights ON when emitting laser.

## ▣ Dimensions

### ◎ Sensor head

(unit: mm)

#### • BD-030

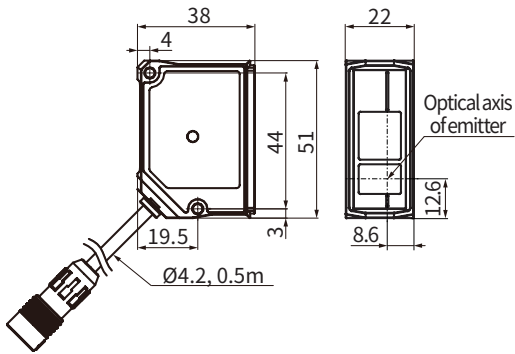

#### • BD-065/100

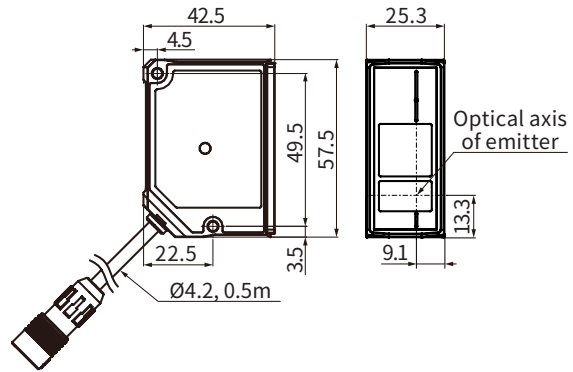

#### • Brackets • BD-030

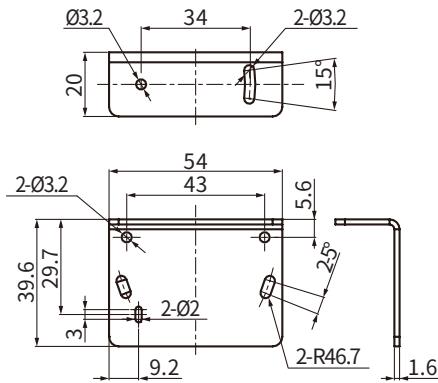

#### • BD-065/100

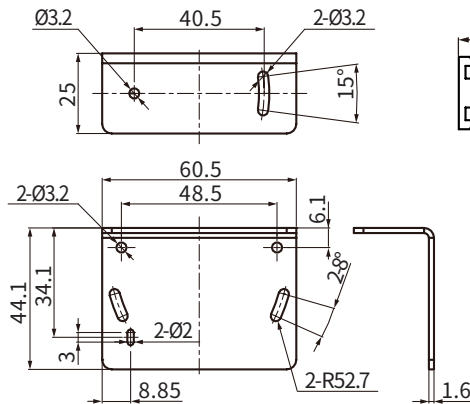

#### • Ferrite core (accessory)

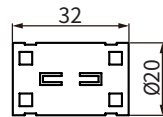

### ◎ Amplifier unit

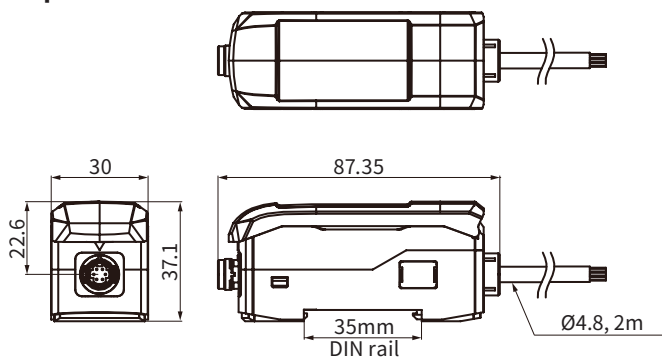

#### • Bracket

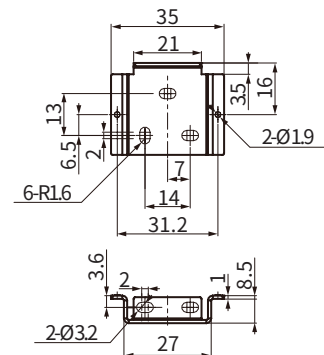

#### • Extension cable (sold separately)

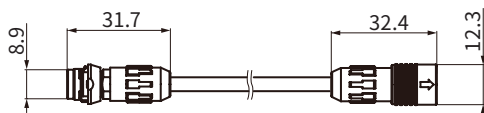

# Laser Displacement Sensor

## ■ Connections

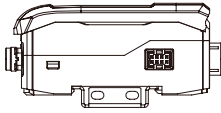

Item	Code color	Description
Power	Brown	Power: 10-30VDC
	Blue	Common GND (input, output, power)
Output	Black	HIGH Judgment
	Orange	LOW Judgment
	Gray	GO Judgment
	Green	Alarm
	White	Analog: Following parameter value (-5-5V, 0-5V, 1-5V, 4-20mA)
	Shield	GND (Analog output) ※It is needed to distinguish from common GND.
	External input	Pink
Yellow		External input 2
Red		External input 3
Purple		External input 4

Select parameters as below and input a signal to execution.  
(Timing, Output reset, Laser OFF, Zero adjustment, BankA, BankB, OFF)

## ■ Control Output Diagram

### ◎ Judgment (High, Go, Low) and alarm output

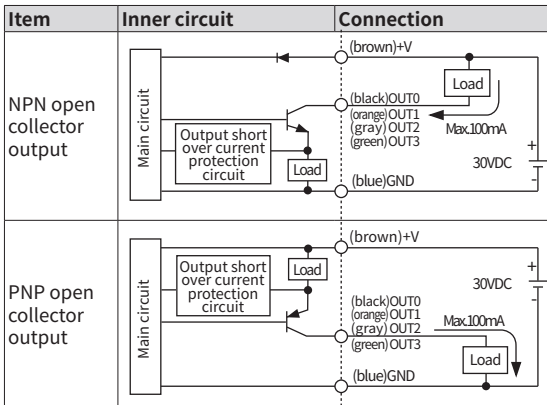

### ◎ Analog output

(-5-5V, 0-5V, 1-5V, 4-20mA)

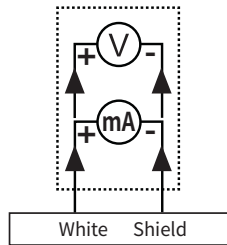

## ■ Installation Procedures

For optimum measurement, install the sensor head according to the following procedure.

Order	Chapter	Description
1	Check reference distance and select mounting location	As the distance between the sensor head and the object approaches the reference distance, accurate measurements can be made. Refer to '■ Mounting Location' to select optimum mounting location.
2	Check the precautions about the measurement	In case of measuring moving or rotating object, it is needed to install the sensor head to correct direction. When measuring at narrow area or concave object, it is needed to set the position of the sensor head. For the details, refer to '■ Installation Precautions'.
3	Check mounting method and mount	Mount to the panel directly or through the enclosed bracket. Refer to '■ Mounting and Connecting Method' to mount the sensor head.
4	Check and apply the function of amplifier unit.	BD series support various settings and functions such as pitch light optimization, zero adjustment setting, automatic sensitivity setting, calculation through the amplifier unit.

## ■ Mounting Location

Select mounting location regarding displacement of the object, reference distance and measurement range.  
Mount sensor head where the object is located at the reference distance by checking the operation of indicators and displacement value.

## ◎ Indicator display

Check the operation of indicators to know distance between sensor head and the object.

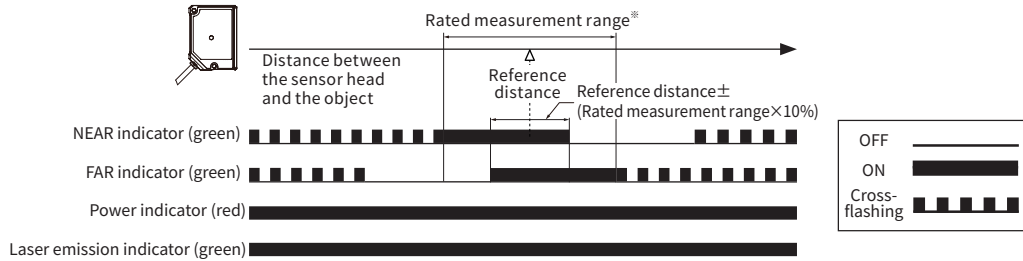

- NEAR/FAR indicators turn on, off and cross-flashing by the distance between the sensor head and the object and the indicator are on both, it means the sensor head is located in optimum area near reference distance.
  - Power indicator is on when power is supplied.
  - Laser emission indicator is on during laser emission.
- ※The linearity guaranteed measurement range.

## ◎ Displacement indication

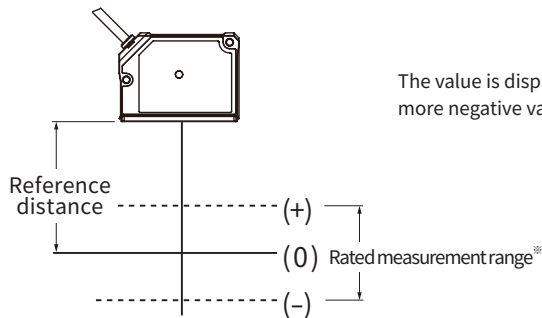

The value is displaced more positive (+) as the object is closer to sensor head, more negative value (-) as the object is far from sensor head relative to the origin (0).

## ◎ Indication by distance

(unit: mm)

Model	Reference distance	Rated measurement range <sup>※</sup>	Indication		
			NEAR ON	NEAR/FAR ON	FAR ON
BD-030	30	25 to 35	25 to 31	29 to 31	29 to 35
BD-065	65	55 to 75	55 to 67	63 to 67	63 to 75
BD-100	100	80 to 120	80 to 104	96 to 104	96 to 120

※The linearity guaranteed measurement range.

# Laser Displacement Sensor

## ■ Mounting and Connecting Methods

### ◎ Sensor head Mounting

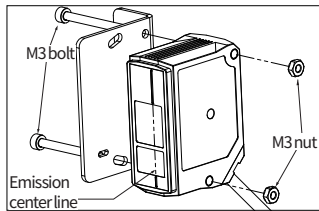

- Check the mounting position considering emission center line, vibration and shock.
- Mount to the panel directly or through the bracket by using M3 bolt and nut.
- Tighten the bolt with 0.5N·m torque when mounting.

### ◎ Amplifier unit Mounting

#### • Mounting with bolt

- Mounting without DIN rail is possible by using bracket.
- The method of mounting and detaching with bracket is as same as DIN rail.

#### • Mounting on DIN rail

##### • Mounting

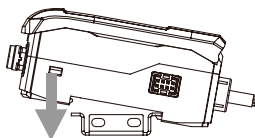

- ① Insert the bottom holder of amplifier unit to 35mm width DIN rail.
- ② Push the front part of the unit to arrow direction to mount.

##### • Detaching

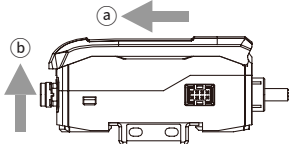

- ① Side amplifier unit to a direction.
- ② Pull the assembly part to b direction to detach.

### ◎ Ferrite core (accessory)

#### • Sensor head

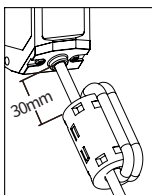

- Within 30mm from the sensor head, wind the cable through the inside of the ferrite core three times and mount the ferrite core.

#### • Extension cable (sold separately)

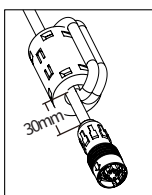

- Within 30mm from the connector of amplifier unit, wind the cable through the inside of the ferrite core three times and mount the ferrite core.

### ◎ Connecting to amplifier unit

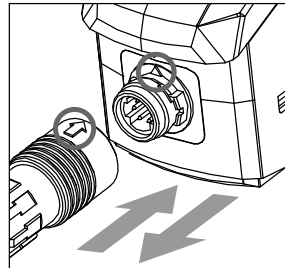

- ① Connecting: Insert connector of the sensor head into amplifier unit with aligning ↑ mark and ▲ mark until it sounds click.
- ② Disconnecting: Pull out the connector cap of sensor head to the opposite direction.

※Do not supply the power when connect / disconnect sensor head to amplifier unit.

### ◎ Connecting amplifier units mutually

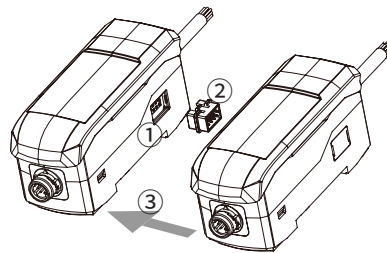

- ① Remove the side cover at the connecting side.
  - ② Connect the side connector to the units.
  - ③ After mounting amplifier unit on DIN rail, push it to arrow direction tightly.
- ※In case of disconnecting, follow the upper sequence reversely.

#### • Distinguishing master/slave amplifier units

- When the power cable direction is down, the amplifier at the left end is the master unit, and the channel number of slaves increases sequentially to the right.

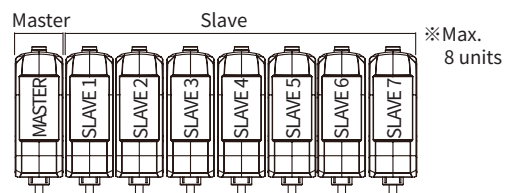

#### • Precautions when connecting amplifier unit

- Mount on DIN rail.
- Do not supply the power when adding amplifier unit.
- Supply power to each connected amplifier unit at the same time.
- Up to 8 amplifier units can be connected, and only 1 calculation function can be performed per 1 group of mutually connected amplifiers.
- When the calculation function is activated, the setting values (SV) of the slave units are disable and the mutual interference prevention function for sensor heads is executed automatically.



## ■ Installation Precautions

For stable measurement, mount the sensor head by referring to the below items.

### ◎ Moving object measurement

#### 1. Object with material / color difference

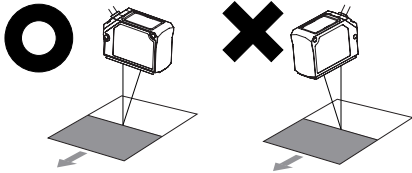

Install the emitter and receiver in parallel to the material or color boundary of the object.

#### 2. Rotating object

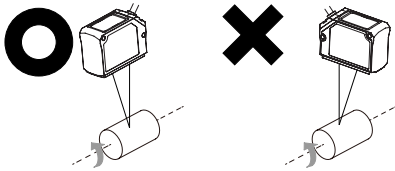

Install the receiver and the rotating shaft in parallel to minimize the influence of fluctuations and position deviations.

#### 3. Object with step

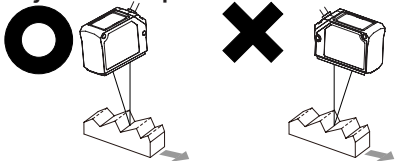

Install the emitter and receiver vertically to the line between crest and valley of the object.

### ◎ Narrow area or concave object

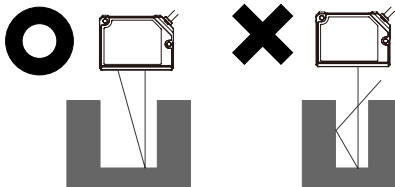

Install the sensor head where the reflected laser beam does not get blocked toward the receiver part.

### ◎ Wall mounting

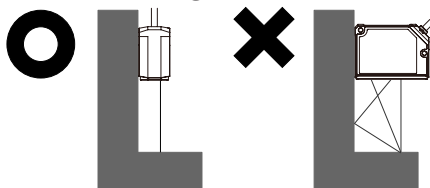

Install the sensor head where the reflected laser beam from the wall does not enter the receiver part.  
If the color of wall is black with low reflectivity and no gloss, the error can be minimized.

### ◎ Black object

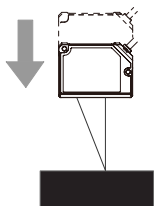

When measuring black object with low reflectance the amount of light received decreases, install the sensor head closely to the object.

# Laser Displacement Sensor

## Parameter Setting

Mode	Key	Description
Run mode		Present value (PV) display <ul style="list-style-type: none"> <li>• Solo: Displays present value (PV).</li> <li>• When using calculation: Displays the result of calculation, and calculation indicator (CALC) of master amplifier unit turns on.</li> </ul>
		Setting value(SV) display Can change the type of value by the [◀/▶] keys, and each recognition lamp turns on. Setting range: HIGH setting value, LOW setting value, real distance value (RV), analog output, bank (Displays [bANK-□] and all the recognition lamps turn off.)
Sensing optimization	[AUTO] key over 2 sec	Optimizes the level of laser emission and receiving sensitivity regarding the object color and environment. Execution: Execute automatically when entering the mode.
Zero adjustment	[ZERO] key over 2 sec	Sets the present value (PV) to the reference distance forcibly. Execution: After entering the mode, push the [ZERO] key within 1 sec, or apply the signal to external input wire for zero adjustment over 3 sec. Dismiss: Push the [ZERO]+[MODE] keys over 2 sec, or apply the signal to external input wire of zero adjustment over 3 sec. ※If the present value is changed by zero adjustment, the setting values (HIGH SV, LOW SV etc.) are not changed.
HIGH sensitivity adjustment	[MODE]+[▲] key over 2 sec	Sets the judgment output (HIGH/GO/LOW) range by manual input. Can change the number of digit by the [◀/▶] keys, and setting value by the [▲/▼] keys. The recognition lamps display the type of sensitivity adjustment.
LOW sensitivity adjustment	[MODE]+[▼] key over 2 sec	
Auto sensitivity adjustment (Teaching)	[MODE] key within 2 sec	Set the judgment output (HIGH/GO/LOW) range automatically. Enter the auto sensitivity adjustment setting mode after set the type of teaching mode in parameter 1 group.
		<ul style="list-style-type: none"> <li>• 1-point teaching                Sets the judgment output range by using present value (PV) of reference object height.                HIGH setting value=height present value × 1.5                LOW setting value=height present value ÷ 2                Setting: 1. 'IP' is displayed on setting value (SV) display, push the [AUTO] key within 2 sec.                2. After teaching the object for 2 sec, set the judgment output range automatically by applying the result.</li> <li>• 2-point teaching                Sets the judgment output range by using present value (PV) of reference object step.                HIGH setting value=(step × 1.5)+bottom height                LOW setting value=(step ÷ 2)+bottom height                Setting: 1. 'IP' is displayed on setting value (SV) display, push the [AUTO] key within 2 sec.                2. After teaching the object for 2 sec, '2P' is displayed on setting value (SV) display, push the [AUTO] key within 2 sec.                3. After teaching the object for 2 sec, set the judgment output range automatically by applying the result.</li> </ul>
Control output type	[MODE]+ [AUTO] key over 2 sec	Sets the type of control/analog output. Setting: Select the setting value by [▲/▼] key, and apply by [MODE] key. <ul style="list-style-type: none"> <li>• Setting range                control output 'OUT': NPN output 'NPN', PNP output 'PNP'                analog output 'A-OUT': Disable 'OFF', 4-20mA current output '4-20mA',                0 to 5V voltage output '0-5V', 1 to 5V voltage output '1-5V',                -5 to 5V voltage output '-5-5'</li> </ul> After setting is finished, flashes 'OUT.SET' on present value(PV) display and 'END' on setting value (SV) display 3 times, and returns to run mode.
HIGH PEAK value	[▲] key	Displays HIGH/LOW PEAK value. If there is direction key input or no key input for 5 sec, returns to run mode.
LOW PEAK value	[▼] key	If push the [▲/▼] key over 3 sec during HIGH/LOW PEAK value display mode, initializes the value. If there is no value, displays 'HHHH'/'LLLL'.
Parameter group	[MODE] key over 2 sec	Enters to the parameter group 1 to 4.

## Parameter Group

- Push the [MODE] key over 2 sec to enter the parameter setting mode.
- In the setting mode, change the parameter group by the [◀/▶] keys and enter the group by pushing the [MODE] key.
- In the group, change the parameter by the [◀/▶] keys, select it by pushing the [MODE] key, and change the setting value by [▲/▼] keys
- In the each step, push the [MODE] key over 3 sec to save and return to the upper step.

※Some parameters are enable by related parameter setting.

PARAM1 Parameter group 1 Settings related to output type, displacement, display and error output.			
Parameter	Setting range	Default	
RSPd	Response time	330μs, 500μs, 1ms, 2ms, 5ms	1ms
SENS	Teaching mode	1PNt 1-point 2PNt 2-point	1PNt
NoNC	Output type	No Normally open NC Normally closed	No
dISP	PV display	StNd Standard ScALe Scale	StNd
dot	Display digit	0.000, 0.00, 0.0, 0	0.000
H-Sc	Display scale	-99.999 to 99.999	Different by models
L-Sc	Display scale	-99.999 to 99.999	Different by models
HYS	Hysteresis	0.001 to 99.999	0.001
H-AN	Analog output scale	-99.999 to 99.999	Different by models
L-AN	Analog output scale	-99.999 to 99.999	Different by models
ERR.oUt	Error output	KEEP Keep PV FIx Fixed value	KEEP
FIx.oUt	Fixed output	Set analog output range	Max. value

PARAM2 Parameter group 2 Settings related to present value.			
Parameter	Setting range	Default	
CLC	Calculation	oFF Off Add-Ab Add Sub-Ab Subtraction AVG Average mode	oFF
GAIn	Gain	1, 2, 3	1
FILeTER	Filter	AVF Average filter dIFF Differential filter	AVF
AVF	Samples for averaging	1, 2, 4, 8, 16, 32, 64, 128, 256, 512, 1024, 2048, 4096	16
MEdIAN	Samples for median	oFF, 3, 5, 7, 15, 31	oFF
HoLd	Hold	oFF Off PEAK Peak boTtOm Bottom P-P Difference SAMPLe Sample AVG Average	oFF
HoLd.t	Hold timing input	t-IN External input AUt Over auto trigger level AUd Under auto trigger level	t-IN
Aut.Lv	Auto trigger level	-99.999 to 99.999	0
Aut.HYS	Auto trigger hysteresis	0.001 to 99.999	0.001
t-Mod	Timer	oFF Off oNd Output delay oFd Output hold	oFF
tIME	Timer value	0 to 9999	0

PARAM3 Parameter group 3 Settings related to external input.			
Parameter	Setting range	Default	
d-IN1	External input 1	oFF Off t-IN Timing input	t-IN
d-IN2	External input 2	oUeCLR Output reset L-oFF Stop emission	oUeCLR
d-IN3	External input 3	ZERo Zero adjustment bANK-A Bank input-A	L-oFF
d-IN4	External input 4	bANK-b Bank input-B	ZERo

PARAM4 Parameter group 4 Settings related to user convenience functions.			
Parameter	Setting range	Default	
dIR	Display direction	[▲/▼] (select direction) → [MODE] (apply)	Normal display
bANK	Bank	bANK-0, -bANK-1 bANK-2, -bANK-3	bANK-0
SAVE	Saving mode	oFF Off SAVE1 Digital display SAVE2 All display	oFF
LoCK	Lock mode	oFF Off LoCK1 [AUTO], [ZERO] LoCK2 [AUTO], [ZERO] +entering parameter group LoCK3 All key (except unlock key)	oFF
INIte	Initialize	oFF, CLR-b0, CLR-b1, CLR-b2, CLR-b3, CLR-A	oFF

※Parameter group 4 is common, not saved per bank separately.

# Laser Displacement Sensor

## ■ Display When Power is ON

Displays control output setting screen when connecting a sensor head and supplying power at the first time, or replacing a sensor head. Set the output type as below sequence.

Refer to '■ Parameter setting' to check the setting range and the reset method.

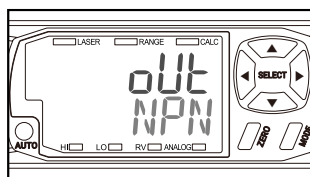

① When 'out NPN' is displayed on the present value (PV) display, select control output type through the [▲/▼] keys and push the [MODE] key.

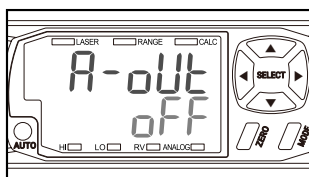

② When 'A-out off' is displayed on the present value (PV) display, select analog output type through the [▲/▼] keys and push the [MODE] key.

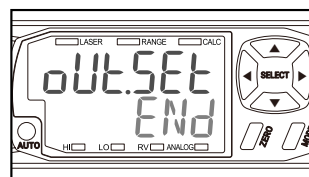

③ After 'outSET' is flashed three times and it returns to the run mode.

## ■ Error Display

In error status, 'ERR' is displayed on present value (PV) display.

Deal with an error by referring to the below solution of each setting value (SV) display.

Setting value (SV) display	Output	Reason	Solution
HEAD	O	Disconnection of sensor head/ amplifier unit/cable Sensor head malfunction	Check the connection between sensor head and amplifier unit. Check the disconnection of sensor head cable. Perform the above items and supply the power again.
LASER	O	Malfuction of emission	If the problem is not resolved after the above items are performed, it is judged that the sensor head is defective and needs to be replaced.
MARK	—	Not existing the object or background in maximum measurement range	Adjust the distance between sensor head and object in the maximum measurement range.
RANGE	—	Over receive the light	
BRUSH	—	In status of display unavailable	Return to status of present value display available.
A-MEM	O	Amplifier unit memory malfuction (EEPROM cannot be refreshed due to exceeding the number of recording over 1 million times)	Turn off the power, check the connection of sensor head, and supply the power again. Executes the initialize 'INIT' function. If the problem is not resolved after the above items are performed, it is judged that the amplifier unit is defective and needs to be replaced.
H-MEM	O	Sensor head memory malfuction	Turn off the power, check the connection of sensor head, and supply the power again. If the problem is not resolved after the above item is performed, it is judged that the amplifier unit is defective and needs to be replaced.
AMP-C	O	Poor connection between amplifier units.	Check the connection between amplifier units, and supply the power again.
VER	O	Mismatch the version of firmware between sensor head and amplifier unit.	Please contact the Autonics technical advisory center.
OUT	O	Disconnection of the judgment output	After turn off the power, check connection of HIGH (black) / GO (gray) / LOW (orange) wire, and supply the power again.
OUTO	—	Teaching failure	After check the object is in the maximum measurement range, execute again.
AMP	O	Amplifier unit error	After turn off the power, check the connection of sensor head, and supply the power again. If the problem is not resolved after the above items are performed, it is judged that the amplifier unit is defective and needs to be replaced.
OCUR	O	Over current of output terminal	Check the load of output is specification range. Check the output is contacted other wire or frame.

## ■ Cautions during Use

1. Follow instructions in 'Cautions during Use'. Otherwise, it may cause unexpected accidents.
2. The power supply should be insulated and limited voltage/current or Class 2, SELV power supply device.
3. Do not install where strong magnetic or electric field exist. Otherwise, the resolution may be adversely affected.
4. Mutual optical interference between laser sensors and photoelectric sensors may result in malfunction.
5. Mutual optical interference between laser sensors may result in malfunction.
6. When connecting DC relay or other inductive load to the output, remove surge by using diode or varistor.
7. Wire as short as possible and keep away from high voltage lines or power lines, to prevent surge and inductive noise.  
[Amplifier unit]
8. For the optimized performance, it is recommended to measure after 30 minute from supplying power. [Amplifier unit]
9. Since external disturbance light (sunlight, fluorescent lighting, etc.) can cause product malfunction, use the product with a light shield or slit. [Sensor head]
10. When detecting with the maximum sensitivity, an error may occur depending on each characteristic deviation.
11. This unit may be used in the following environments.
  - ①Indoors/Outdoors (in the environment condition rated in 'Specifications')
  - ②Altitude max. 2,000m
  - ③Pollution degree 2
  - ④Installation category II