

Photoelectric Sensors

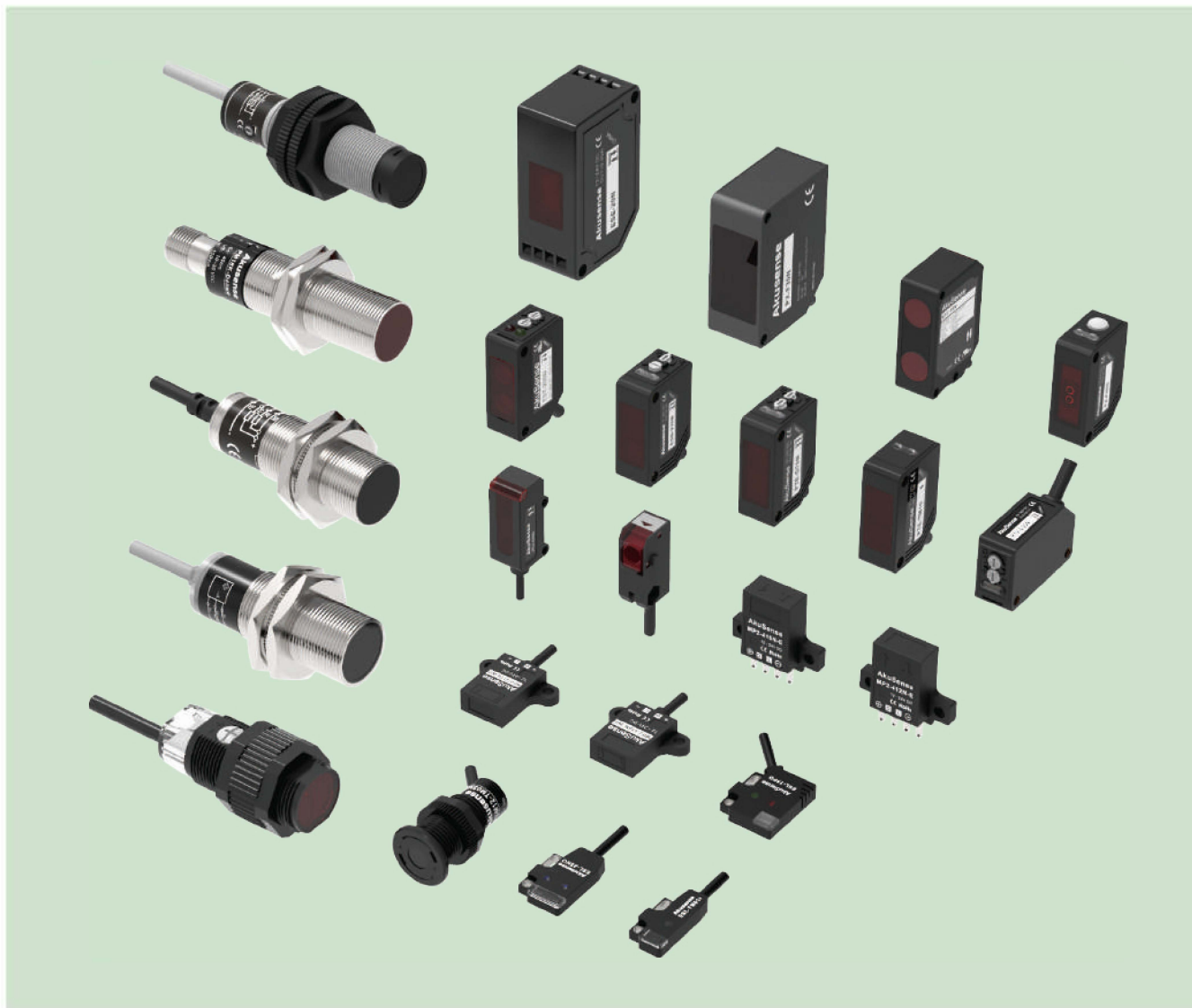

- Available in a variety of models, like thin type, square type, cylindrical type, transparent object detection type, background suppression type, etc.
- L.on and D.on switch freely.
- Solid and durable metal housing; Economical plastic housing and easy to install.
- Short circuit protection and reverse polarity protection.
- Switch frequency up to 5000Hz.

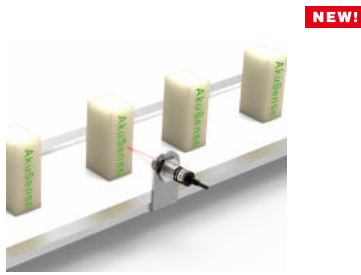

NEW!

Cylindrical Type (PM/PSM/PXM Series)

- Epoxy resin fillings ,powerful in shock resistance
- The smallest diameter(8mm) in the industry
- Nickel plated brass, effectively resist chemicals' corrosion

P.C-07

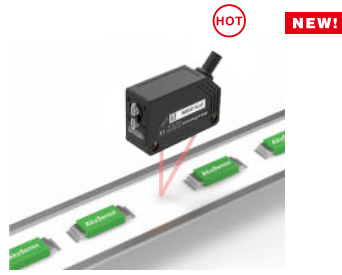

HOT

NEW!

Square Type (PTE/PTEW/PTV/PTVW/PTN/PTJ-I Series)

- Traditional square housing with great performance
- 25.4mm standard hole pitch for simple installation
- Identifying the action clearly with dual LED indicators

P.C-16



HOT

Flat Type (MP2 Series)

- Sensing surfaces on top side and front side support various detections
- Can switch L.on and D.on switch flexibly
- Long distance detection up to 40mm(white cardboard)

P.C-28

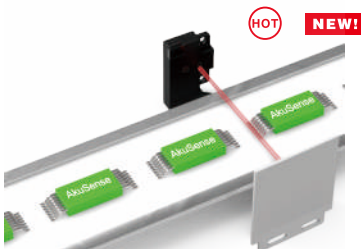

HOT

NEW!

Thickness is only 3.5mm

Thin Type (ESL series)

- 3.5mm ultra-thin design, greatly saves installation space
- Ip67 Protection degree , excellent mechanical performance
- LED indicator is bright and can be clearly seen from the back

P.C-30



NEW!

HOT

Not affected by background color

BGS Type (ESB Series)

- Free from objects and background colors with stable detection
- Built-in rotational knobs, with many turns for fine-tuning of sensitivity adjustment
- IP67 protection degree, with excellent mechanical performance

P.C-32



HOT

Transparent Object Detection (EST Series)

- No blind spot (detection for every corner)
- Suitable for moving objects
- Best options for different kinds of glass or plastics

P.C-35



NEW!

RGB Light Source

Color/Mark Detection (ESC/ESE Series)

- Built-in RGB light sources
- Automatic adjustment to the most suitable light source according to the detected color
- Two detection modes, mark and color

P.C-37



NEW!

TOF Principle Type (PM18-TF/PX series)

- Up to 3 meters range
- TOF principle, high stability
- Independent of object color, background color and reflectivity

P.C-27



IP69K High Protection Type (PM18K Series)

- AISI 316L stainless steel housing material
- Protection grade IP69K, excellent mechanical performance
- Applied in harsh environments.

P.C-12



Anti-glare Type (PTL Series)

- Not interfered by glare, with stable detection
- Built-in multi-turn potentiometer for fine adjustment of sensitivity
- IP67, excellent mechanical performance

P.C-19



IO-Link Type (PTZ-C Series)

- With IO function, contributing to industrial 4.0
- Identify the action clearly with dual LED indicators
- IP67, excellent mechanical performance

P.C-23

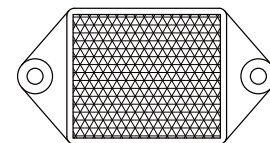

Reflectors

- Made of special material (robust housing)
- Shapes as circular, square and combination etc
- Customization is available as requested by clients

P.C-39

Fiber Optic
Slot Sensors
Photoelectric
Laser
Proximity
Displacement
Magnetic
Contact
Area
Ultrasonic
Vision
Code Readers
Vibration
Temperature
Accessories

Guidance

Photoelectric

Cylindrical
Square
Flat type
Thin type
BGS
Transparent detection
Color/Mark Detection
TOF type
IP69K high protection type
Anti-glare type
IO-Link type

Reflectors

Reflectors







- Fiber Optic
- Slot Sensors
- Photoelectric**
- Laser
- Proximity
- Displacement
- Magnetic
- Contact
- Area
- Ultrasonic
- Vision
- Code Readers
- Vibration
- Temperature
- Accessories

Guidance

- Photoelectric**
- Cylindrical
- Square
- Flat type
- Thin type
- BGS
- Transparent detection
- Color/Mark Detection
- TOF type
- IP69K high protection type
- Anti-glare type
- IO-Link type
- Reflectors**
- Reflectors



Type	Light Source	Series	
Photoelectric	Red Light/ Infrared Light/ RGB	Cylindrical Type	PM/PSM/PXM Series
		Square Type	PTE/PTEW/PTV/PTVW/ PTN/PTJ-I Series
		Flat Type	MP2 Series
		Thin Type	ESL Series
		BGS Type	ESB Series
		Transparent Object Detection	EST Series
		Color/Mark Detection	ESC/ESE Series
		TOF Principle Type	PM18-TF/PX Series
		IP69K High Protection Type	PM18K Series
		Anti-glare Type	PTL Series
IO-Link Type	PTZ-C Series		

Cylindrical

Series	Sensing type	Sensing distance	Model No.		Pages	
			NPN L.on&D.on	PNP L.on&D.on		
PM08	 (Infrared light)	Diffuse reflection	3cm	L.on:PM08-D03NO (HOT)	L.on:PM08-D03PO	C-07
PM18 (Metal housing)	 (Infrared light)	Diffuse reflection	10cm	PM18-D10NR	PM18-D10PR	C-08
			40cm	PM18-D40NR	PM18-D40PR	
		Thru-beam	1000cm	PM18-TM10NR	PM18-TM10PR	
			2000cm	PM18-TM20NR	PM18-TM20PR	
PM18 (Economical Type)	 (Infrared light)	Retro-reflection Diffuse reflection	10cm	L.on:PM18-D10NO	L.on:PM18-D10PO	C-09
			500cm	PM18-TM05NO	PM18-TM05PO	
		Thru-beam	2000cm	PM18-TM20NO	PM18-TM20PO	
			2000cm	PM18-TM20NC	PM18-TM20PC	
PXM18 (PBT housing)	 (D10 Red light) (D40 Infrared light)	Diffuse reflection	10cm	PXM18-D10N	PXM18-D10P	C-15
			40cm	PXM18-D40N	PXM18-D40P	
PSM12	 (Infrared light)	Thru-beam	500cm	PSM12-TM05NO PSM12-TM05NC	PSM12-TM05PO PSM12-TM05PC	C-13
PSM18	 (Red light)	Diffuse reflection	10~40cm	PSM18-D40N	PSM18-D40P	C-14

- Fiber Optic
- Slot Sensors
- Photoelectric**
- Laser
- Proximity
- Displacement
- Magnetic
- Contact
- Area
- Ultrasonic
- Vision
- Code Readers
- Vibration
- Temperature
- Accessories

Square

Series	Sensing type	Sensing distance	Model No.		Pages		
			NPN L.on&D.on	PNP L.on&D.on			
PTE	 (Red light)	Diffuse reflection	1~30cm	PTE-D30N (HOT)	PTE-D30P	C-16	
			0.5~100cm	PTE-D70N	PTE-D70P		
		Convergent reflective	0.5~14cm	PTE-X09N (HOT)	PTE-X09P		
			Retro-reflection	1~20cm	PTE-R20N		PTE-R20P
				200cm	PTE-R200N		PTE-R200P
		Thru-beam	300cm	PTE-R300N	PTE-R300P		
			1000cm	PTE-TM10NO	PTE-TM10PO		
				PTE-TM10NC	PTE-TM10PC		
PTEW	 (PTEW Red light PTVW Infrared light)	Diffuse reflection	0.5~20cm	PTEW-D20N	PTEW-D20P	C-18	
			10cm	PTVW-D10N	PTVW-D10P		
			20cm	PTVW-D20N	PTVW-D20P		
PTV	 (Infrared light)	Diffuse reflection	1~30cm	PTV-D30N	PTV-D30P	C-20	
			0.5~100cm	PTV-D70N	PTV-D70P		
		Convergent reflective	0.5~14cm	PTV-X09N	PTV-X09P		
			Thru-beam	500cm	PTV-T500N		PTV-T500P
		2000cm		PTV-TM20NO	PTV-TM20PO		
				PTV-TM20NC	PTV-TM20NC		
				PTV-TM20AN	PTV-TM20AP		



- Guidance
- Photoelectric**
- Cylindrical
- Square
- Flat type
- Thin type
- BGS
- Transparent detection
- Color/Mark Detection
- TOF type
- IP69K high protection type
- Anti-glare type
- IO-Link type
- Reflectors**
- Reflectors

Guidance



Square

PTN	 (Infrared light)	Diffuse reflection	5cm	PTN-D05N	PTN-D05P	C-25
		Thru-beam	50cm	PTN-T50N	PTN-T50P	
PTJ-I	 (Infrared light)	Thru-beam	80cm	D.on:PTJ-T80NO-I	D.on:PTJ-T80PO-I	C-26
				L.on:PTJ-T80NC-I	L.on:PTJ-T80PC-I	
		Thru-beam	150cm	D.on:PTJ-T150NO-I	D.on:PTJ-T150PO-I	
				L.on:PTJ-T150NC-I	L.on:PTJ-T150PC-I	



Thin Type

Series	Sensing type	Sensing distance	Model No.		Pages	
			NPN L.on&D.on	PNP L.on&D.on		
ESL	 (Infrared light)	Convergent reflective	2~15mm	ESL-15NO	ESL-15PO	C-30
		Diffuse reflection	2~25mm	ESL-25NO	ESL-25PO	
	 (Red light)	Thru-beam	500mm	ESL-T50NO	ESL-T50PO	
		Thru-beam	100cm	ESL-TM01NO	ESL-TM01PO	

BGS



Series	Sensing type	Sensing distance	Model No.		Pages	
			NPN L.on&D.on	PNP L.on&D.on		
ESB	 (Red light)	Diffuse reflection	0.5~10cm	ESB-S10N	ESB-S10P	C-32
		Diffuse reflection	0.5~15cm	ESB-15N	ESB-15P	
		Diffuse reflection	0~30cm	ESB-30N	ESB-30P	
	 (Infrared light)	Diffuse reflection	1~30cm	ESB-V30N	ESB-V30P	C-33
 (Red light)		Diffuse reflection	1~20cm	ESB-C20N	ESB-C20P	

Flat



Series	Sensing type	Sensing distance	Model No.		Pages	
			NPN L.on&D.on	PNP L.on&D.on		
MP2 (Connector)	 (Infrared light)	Diffuse reflection	40mm	MP2-410N-E 	MP2-410P-E	C-28
		Diffuse reflection	40mm	MP2-412N-E	MP2-412P-E	
MP2 (Pre-wired)	 (Infrared light)	Diffuse reflection	2.5~8mm	D.on: MP2-410N-WD	D.on: MP2-410P-WD	C-29
				L.on: MP2-410N-WL	L.on: MP2-410P-WL	
	Diffuse reflection	2.5~8mm	D.on: MP2-412N-WD	D.on: MP2-412P-WD		
			L.on: MP2-412N-WL	L.on: MP2-412P-WL		

- Fiber Optic
- Slot Sensors
- Photoelectric
- Laser
- Proximity
- Displacement
- Magnetic
- Contact
- Area
- Ultrasonic
- Vision
- Code Readers
- Vibration
- Temperature
- Accessories
- Guidance
- Photoelectric
 - Cylindrical
 - Square
 - Flat type
 - Thin type
 - BGS
 - Transparent detection
 - Color/Mark Detection
 - TOF type
 - IP69K high protection type
 - Anti-glare type
 - IO-Link type
- Reflectors
 - Reflectors



Transparent Detection

Series	Sensing type	Sensing distance	Model No.		Pages	
			NPN	PNP		
EST	 (Red light)	Retro-reflection	1~200cm	EST-200N	EST-200P	C-35
			0~200cm Coaxial beam	EST-X200N 	EST-X200P	

Color/Mark Detection

Series	Sensing type	Sensing distance	Model No.		Pages	
			NPN	PNP		
ESC		Diffuse reflection	16~20mm	ESC-18N	ESC-18P	C-37
ESE	 (RGB)	Diffuse reflection	17~23mm	ESE-20N	ESE-20P	C-38

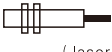
TOF Principle Type

Series	Sensing type	Sensing distance	Model No.		Pages	
			NPN	PNP		
PM18-TF	 (Laser)	Reflection	1.2m	PM18-TF120N	PM18-TF120P	C-11
PX	 (Infrared light)	1 Point teach-in	1m	PX-F09N	PX-F09P	C-27
		1 Point teach-in	3m	PX-F30N	PX-F30P	

IP69K High Protection Type

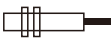
Series	Sensing type	Sensing distance	Model No.	Pages	
PM18K	 (Infrared light)	Diffuse reflection	400mm	PM18K-D40NR	C-12

Anti-glare Type

Series	Sensing type	Sensing distance	Model No.		Pages	
			NPN	PNP		
PTL		Diffuse reflection	5~100mm	PTL-D10N	PTL-D10P	C-19
			10~300mm	PTL-D30N	PTL-D30P	

IO-Link Type

Series	Sensing type	Sensing distance	Model No.	Pages	
PTZ-C		Diffuse reflection	0~1m	PTZ-D70N-C	C-23
		Thru-beam	0~25m	PTZ-TM25N-C	
		Retro-reflection	0.01~4m	PTZ-R400N-C	

- Fiber Optic
- Slot Sensors
- Photoelectric**
- Laser
- Proximity
- Displacement
- Magnetic
- Contact
- Area
- Ultrasonic
- Vision
- Code Readers
- Vibration
- Temperature
- Accessories

Guidance

- Photoelectric**
- Cylindrical
- Square
- Flat type
- Thin type
- BGS
- Transparent detection
- Color/Mark Detection
- TOF type
- IP69K high protection type
- Anti-glare type
- IO-Link type

- Reflectors**
- Reflectors

Cylindrical

PM08 Series



Appearance		
Sensing type	Diffuse reflection	
Sensing distance	30mm (White 30X30mm)	
Hysteresis	< 20%	
Light source	IR Diode(940nm)	
Operating voltage	12~24V DC \pm 10% ripple(p-p) < 10%	
Current consumption	\leq 30mA	
Control output	NPN open-collector output	PNP open-collector output
Switch mode	L.on	
Protection circuit	Short circuit protection, reverse polarity protection, anti-interference protection	
Response time	Action/Reset: < 3ms	
Ambient brightness	Sunlight \leq 10000lux, Incandescent Lamp \leq 3000lux	
Ambient temperature	Operation: $-25^{\circ}\text{C} \sim +55^{\circ}\text{C}$, Storage: $-30^{\circ}\text{C} \sim +70^{\circ}\text{C}$ (No freezing, No condensation)	
Ambient humidity	Operation: 30~85% RH, Storage: 35~95% RH	
Insulation resistance	> 20M Ω	
Withstand voltage	500 V/AC 50/60Hz 1min	
Anti-vibration	10 to 55 Hz with 1.5mm up&down amplitude for 2 hours each in X, Y, and Z directions	
Impact resistance	500m/s ² for 3 times each in X, Y, Z directions	
Degree of protection	IP65	
Connection method	2M 3core cable	
Weight	Approx 80g	
Material	Stainless steel	
Accessories	Mounting screws	
Model No.	PM08-D03NO HOT	PM08-D03PO

Dimensions

Unit: mm

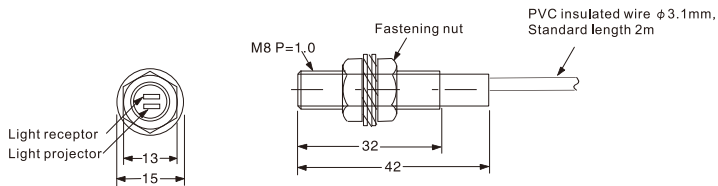

Circuit diagram

NPN Output

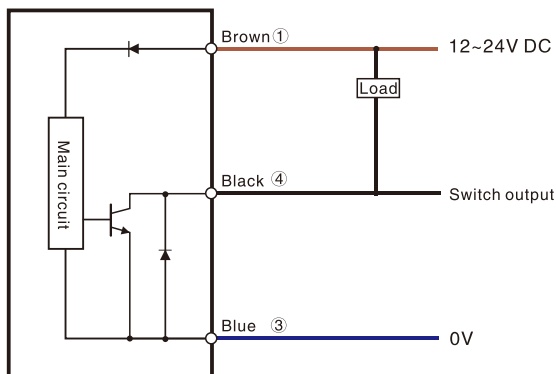

PNP Output

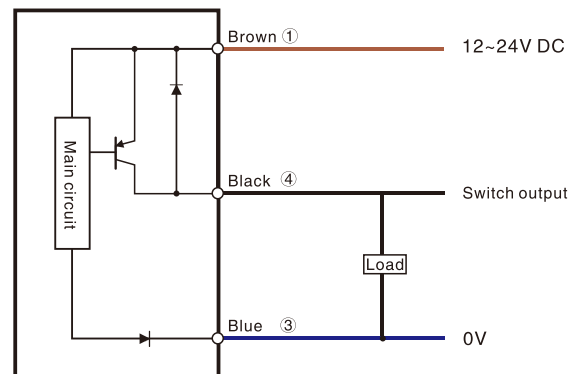



Appearance

Sensing type	Diffuse reflection		Thru-beam		Retro-reflection	
Sensing distance	10cm(fixed)	40cm(adjustable)	1000cm(fixed)	2000cm(fixed)	300cm(fixed)	
Hysteresis	3~20%		...			
Repeat accuracy	< 5%					
Output type	NPN/PNP Open-collector					
Switch type	Selectable L.on/D.on					
Indicator	Yellow LED		Green LED(Emitter)/Yellow LED(Receiver)		Yellow LED	
Response time	< 8.2 ms					
Light source	Infrared LED(880nm)					
Operating voltage	10~30V DC					
Voltage drop	< 2.5V					
Current consumption	< 25mA					
Load current	< 200mA					
Protection circuit	Reverse polarity, short circuit, surge protection					
Ambient temperature	-15°C~+55°C, No freezing					
Ambient humidity	35%~95%RH, No condensation					
Degree of protection	IP67					
Material	Nickel copper alloy					
Connection method	2M 4core cable					
Accessories	Mounting screws					
Model No.	NPN	PM18-D10NR	PM18-D40NR	PM18-TM10NR	PM18-TM20NR	PM18-R300NR
	PNP	PM18-D10PR	PM18-D40PR	PM18-TM10PR	PM18-TM20PR	PM18-R300PR

- Fiber Optic
- Slot Sensors
- Photoelectric**
- Laser
- Proximity
- Displacement
- Magnetic
- Contact
- Area
- Ultrasonic
- Vision
- Code Readers
- Vibration
- Temperature
- Accessories

Dimensions

Unit: mm

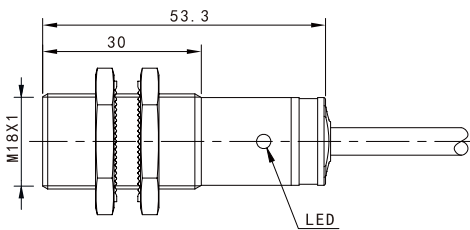

Reflector for PM18-R300

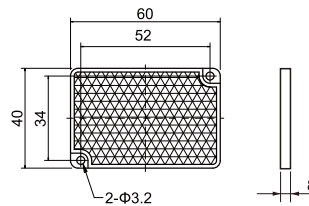

(Standard TD-09)

Circuit diagram

NPN Output

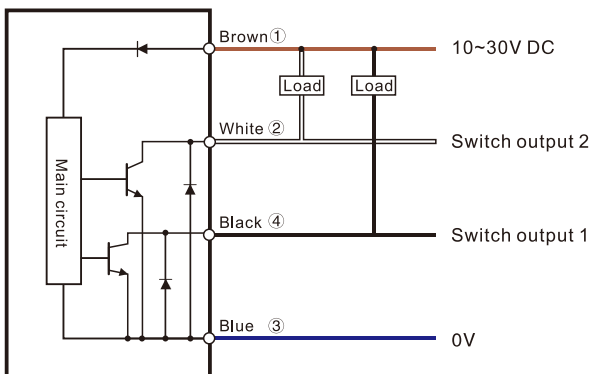

PNP Output

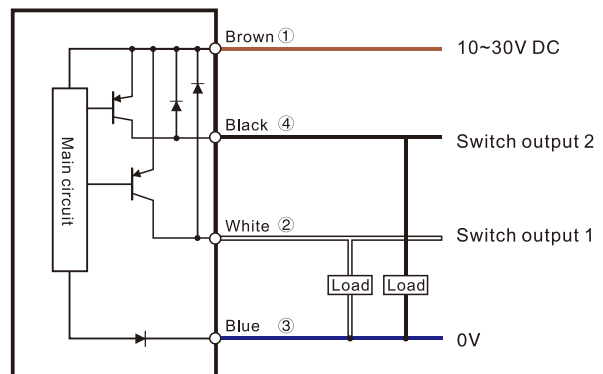

Guidance

Photoelectric

Cylindrical

Square

Flat type

Thin type

BGS

Transparent detection

Color/Mark Detection

TOF type

IP59K high protection type

Anti-glare type

IO-Link type

Reflectors

Reflectors

Cylindrical

PM18 Series

Economical Type



Appearance

	Disffuse Reflection	Thru-beam			
Sensing type	Disffuse Reflection	Thru-beam			
Sensing distance	10cm(fixed)	5m(fixed)	20m(fixed)		
Detected object	100mm × 100mm 90% whiteness white paper	> φ 18mm, opaque			
Output type	NPN Open-collector	NPN/PNP Open-collector			
Switch type	L.on	Selectable L.on/D.on			
Indicator	Motion indicator light: yellow	Transmitter end: power indicator: green; Receiving end: action indicator light: yellow			
Response time	0.5ms	33ms			
Light source	Infrared LED 940nm (modulation)	Infrared LED 850nm (modulation)			
Operating voltage	10~30V DC	12~24V DC	10~24V DC		
Residual voltage	< 2V				
Current consumption	< 25mA	Transmitter < 20 mA; Receiver < 20mA	Transmitter < 25 mA; Receiver < 25mA		
Load current	< 150mA	< 100mA			
Circuit protection	Reverse polarity, short circuit, surge protection				
Ambient temperature	-20°C~+55°C, No freezing	-20°C~+60°C, No freezing			
Storage temperature	-25°C~+65°C	-25°C~+70°C	-20°C~+60°C		
Ambient humidity	35~90%RH, No condensation				
Storage humidity	35~90%RH				
Withstand Voltage	± 1000V 50/60Hz 60s				
Electrostatic	± 4000V				
group value	± 2000V				
Resistance	10~50Hz, 0.5mm amplitude, X, Y, Z direction 2 hours each				
Ambient illuminance	Incandescent lamp: < 3000lux, sunlight: < 10000lux				
Degree of protection	IP67				
Material	Nickel copper alloy				
Connection method	2M 3core cable				
Accessories	Mounting screws				
Model No.	NPN PNP	PM18-D10NO PM18-D10NC	PM18-TM05NO PM18-TM05PO	PM18-TM20NO PM18-TM20PO	PM18-TM20NC PM18-TM20PC

Dimensions

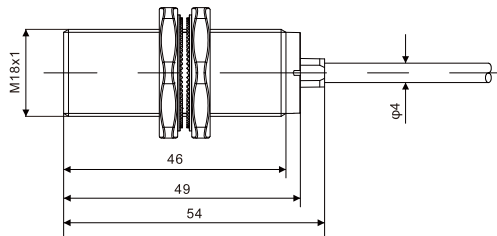

Unit: mm

PM18-D10NO(NC)

NPN Output

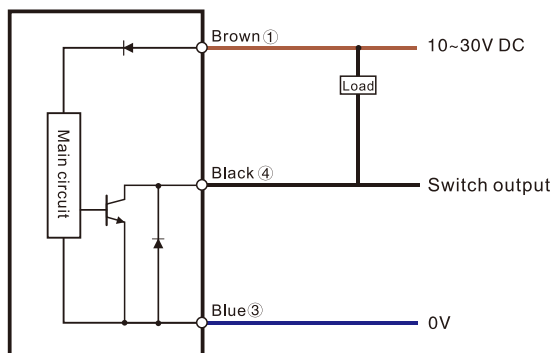

PM18-TM05N(P)O

NPN Output

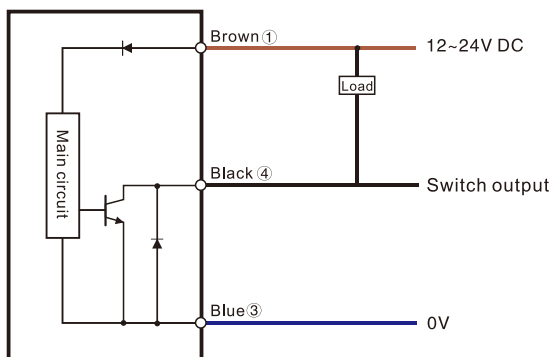

PNP Output

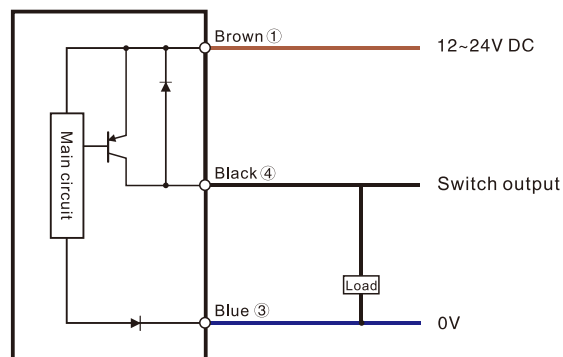

PM18-TM20N(P)O(C)

NPN Output

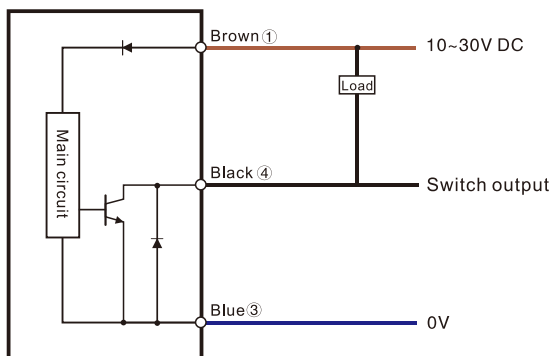

PNP Output

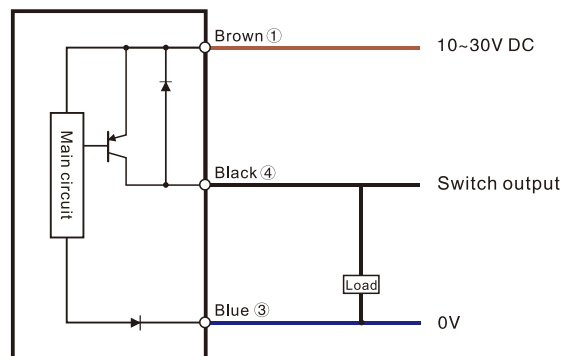

Fiber Optic

Slot Sensors

Photoelectric

Laser

Proximity

Displacement

Magnetic

Contact

Area

Ultrasonic

Vision

Code Readers

Vibration

Temperature

Accessories

Guidance

Photoelectric

Cylindrical

Square

Flat type

Thin type

BGS

Transparent detection

Color/Mark Detection

TOF type

IP69K high protection type

Anti-glare type

IO-Link type

Reflectors

Reflectors

TOF Type Photoelectric

PM18-TF Series

TOF Principle



Appearance

Sensing type	Reflection
Sensing distance	1.2m
Spot divergence angle	30°
Output	NPN / PNP open collector
Switch type	L.on/ D.on selectable
Indicator	Operation: green, Motion: Red
Sensitivity adjustment	multi-turn adjuster
Light source	Laser 940nm (Modulated), class 1
Operating voltage	10~30V DC
Volatge drop	< 1.5V
Current consumption	≦20mA
Load current	≦100mA
Circuit protection	Short circuit,reverse polarity,surge protection
Ambient temperature	-10°C~50°C No freezing
Ambient humidity	35~85% RH, No condensation
Withstand voltage	± 1000V 50/60Hz 60s
Static electricity	± 8000V (air discharge)
Group pulse	± 2000V (5kHz/50kHz)
Impact resistance	10~55Hz amplitude 1.5mm;X, Y, Z 3 directions, 2 hours each
Ambient illuminance	Incandescent lamp: <3,000 lux, Sunlight < 5,000 lux
Degree of protection	IP67
Material	Nickel-copper alloy
Connection	2M 3-core cable
Accessories	Mounting screws
Model No.	NPN PM18-TF120N PNP PM18-TF120P

Dimensions

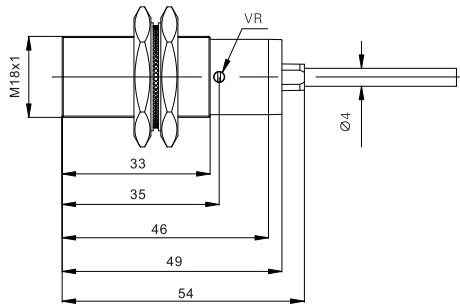

Unit: mm

Circuit diagram

NPN Output

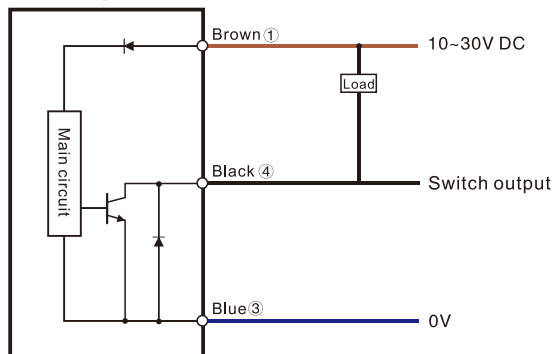

PNP Output

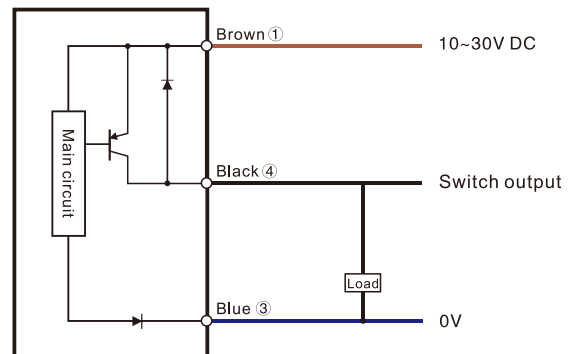

IP69K Type



Appearance	
Sensing type	Disffuse Reflection
Sensing distance	400mm
Light source	IR 880 nm
Hysteresis	≤10%
Repeatability	5%
Tolerance	+15/-5% Sn
Operating voltage	10-30V DC
Ripple factor	≤10%
No load current	Max. 35mA (30V)
Load current	≤100mA
LED	Green: teach-in Yellow: Excess gain
Output voltage drop	2Vmax.IL=100mA
Output type	NPN
Switch frequency	500Hz
Start delay	200ms
Ambient illuminance	Incandescent lamp: <5,000 lux, Sunlight < 10,000 lux
Ambient temperature	-25°C-80°C , no condensation
Circuit protection	Reverse polarity protection, short-term overvoltage protection
Output protection	Short circuit protection (Automatic reset)
Sensitivity	Teach-in
Temperature drift	10%Sr
Degree of protection	IP67; IP68 (1m, 7m /days); IP69K (40050-9 standard)
Material	stainless steel 316
Accessories	Mounting screws
Model No.	PM18K-D40NR

- Fiber Optic
- Slot Sensors
- Photoelectric**
- Laser
- Proximity
- Displacement
- Magnetic
- Contact
- Area
- Ultrasonic
- Vision
- Code Readers
- Vibration
- Temperature
- Accessories

Guidance

Photoelectric

- Cylindrical**
- Square
- Flat type
- Thin type
- BGS
- Transparent detection
- Color/Mark Detection
- TOF type
- IP69K high protection type
- Anti-glare type
- IO-Link type

Reflectors

- Reflectors

Dimensions

Unit: mm

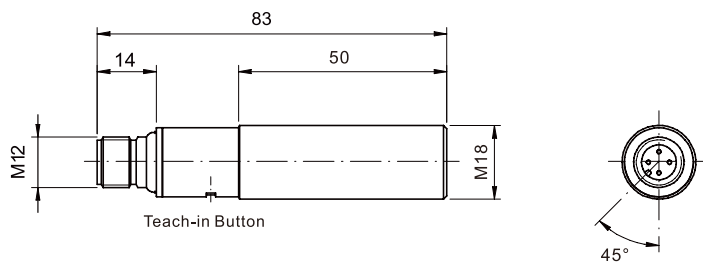

Circuit diagram

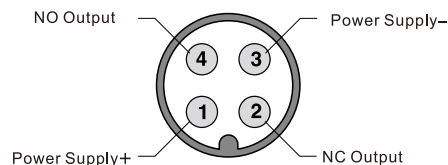
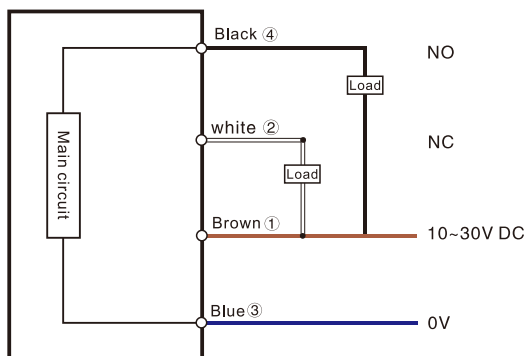

Cylindrical

PSM12 Series



NEW!

Appearance							
Sensing type	Through beam						
Sensing distance	5m						
Light source	Infrared LED						
Detected object	opaque object, $\phi > 8\text{mm}$						
Output	NPN / PNP for option						
Switch type	Light on/ Dark on selectable						
Response time	<2ms						
Indicators	Power: Green, Operation indicator: Orange						
Power supply	12~24V DC $\pm 10\%$ Ripple P-P10% or less						
Residual voltage	< 1 V (When input current is equal to 50 mA)						
Current consumption	Emitter < 18 mA, Receiver < 15 mA						
Load current	<50mA						
Circuit protection	Short circuit protection						
Ambient temperature	Operation: $-25\sim 55^{\circ}\text{C}$; storage: $-30\sim 70^{\circ}\text{C}$, no freezing						
Ambient humidity	Operation: 30~90% RH, storage: 35~85% RH, no condensation						
Degree of protection	IP67						
Material	Housing, lens: PC						
Connection	Emitter: 2m 2 core cable; Receiver: 2m 2 core cable						
Weight	Approx.25g						
Model No.	<table border="1"> <tr> <td>NPN</td> <td>PSM12-TM05NO</td> <td>PSM12-TM05NC</td> </tr> <tr> <td>PNP</td> <td>PSM12-TM05PO</td> <td>PSM12-TM05PC</td> </tr> </table>	NPN	PSM12-TM05NO	PSM12-TM05NC	PNP	PSM12-TM05PO	PSM12-TM05PC
NPN	PSM12-TM05NO	PSM12-TM05NC					
PNP	PSM12-TM05PO	PSM12-TM05PC					

Dimensions

Unit: mm

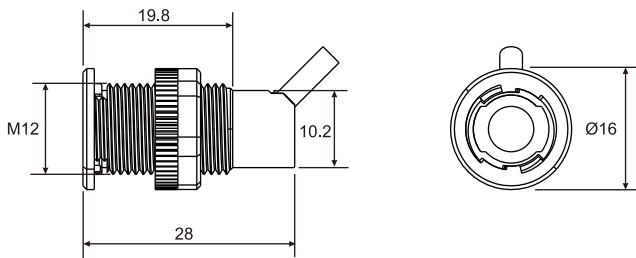

Circuit diagram

NPN Output

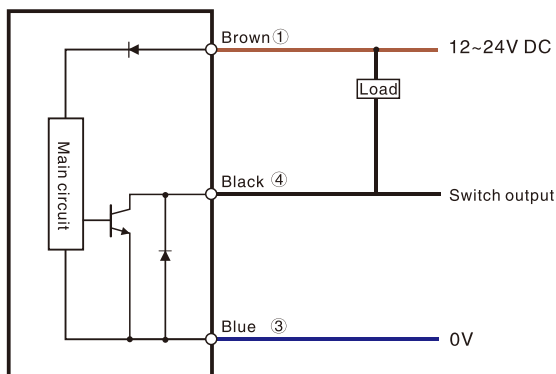

PNP Output

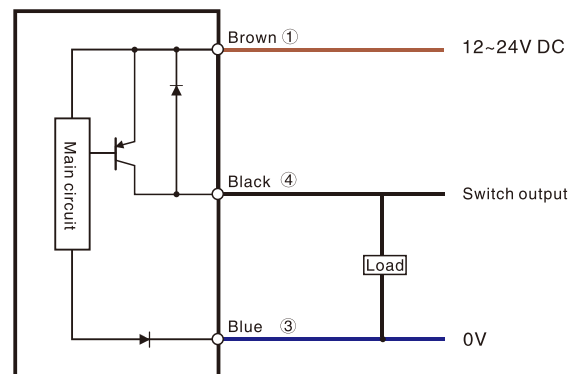



Appearance	
Sensing type	Diffuse reflective
Sensing distance	10~40 cm (adjustable)
Light source	Red light LED
Detected object	opaque object, $\phi > 7$ mm
Output	NPN / PNP for option
Switch Type	Light on/ Dark on selectable
Indicators	Power: Green, Operation indicator: Red
Power supply	10~30V DC
Residual voltage	<1.5V
Current consumption	<25mA
Load current	<120mA
Response time	<2ms
Circuit protection	reverse polarity protection, short circuit protection
Ambient temperature	-15~55°C, no freezing
Ambient humidity	35~90% RH, no condensation
Ambient illuminance	LED \leq 450 Lux
Withstand voltage	\pm 1000V 50/60Hz 60s
Static electricity	\pm 8000V
Group pulse	\pm 2000V 5KHz/100KHz
Anti-vibration	10~50Hz, amplitude 0.5mm; 2 hours each in X, Y, Z directions
Degree of protection	IP67
Material	PC
Connection	2m 4 wire cable
Model No.	NPN PSM18-D40N PNP PSM18-D40P

- Fiber Optic
- Slot Sensors
- Photoelectric
- Laser
- Proximity
- Displacement
- Magnetic
- Contact
- Area
- Ultrasonic
- Vision
- Code Readers
- Vibration
- Temperature
- Accessories

Guidance

Photoelectric

Cylindrical

Square

Flat type

Thin type

BGS

Transparent detection

Color/Mark Detection

TOF type

IP59K high protection type

Anti-glare type

IO-Link type

Reflectors

Reflectors

Dimensions

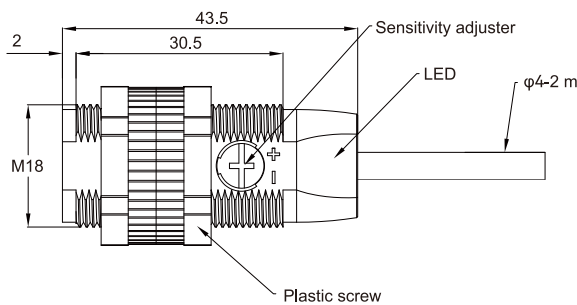

Unit: mm

Circuit diagram

NPN Output

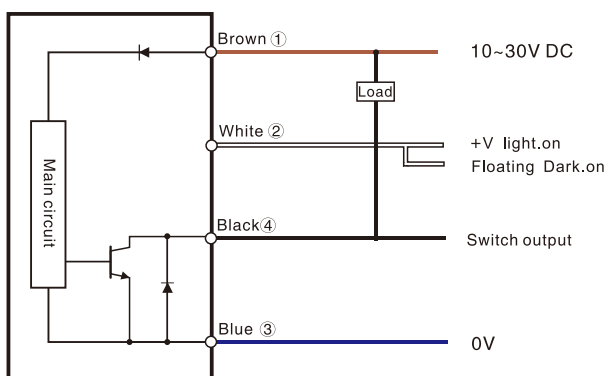

PNP Output

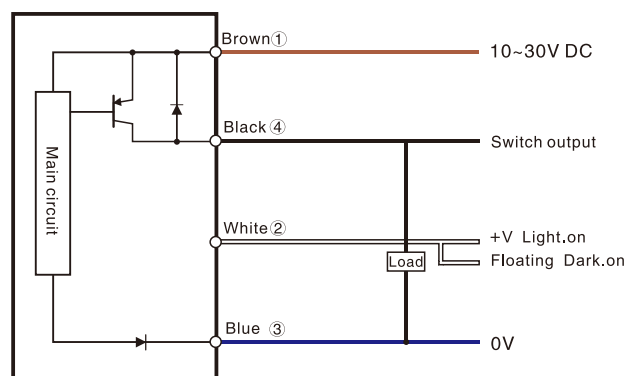

Cylindrical

PXM18 Series



Appearance

Sensing type	Diffuse reflection	
Sensing distance	10cm(adjustable)	40cm(adjustable)
Hysteresis	≤10%	
Repeat accuracy	5%	
Output type	NPN/PNP Open-collector	
Switch type	Selectable L.on/D.on	
Response time	20ms	
Indicator	Red LED(660nm)	Red LED(880nm)
Operating voltage	10~30V DC(±10%)	
Voltage drop	2V max 1L=100mA	
Leakage current	10 μA	
Current consumption	30mA	
Load current	100mA	
Circuit protection	Reverse polarity protection, output short circuit protection, pulse overvoltage protection	
Ambient temperature	-25°C~+70°C, No freezing	
Ambient illuminance	Sunlight ≤10000 lux, Incandescent lamp ≤3000 lux	
Degree of protection	IP67	
Tightening torque	1Nm	
Material	Housing: PBT, Lens: PC	
Weight	≈50g	
Connection method	2M 4core cable	
Accessories	Mounting screws	
Model No.	NPN	PXM18-D10N
	PNP	PXM18-D10P
		PXM18-D40N
		PXM18-D40P

Dimensions

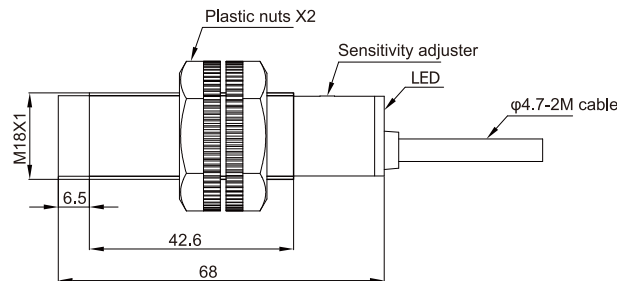

Circuit diagram

NPN Output

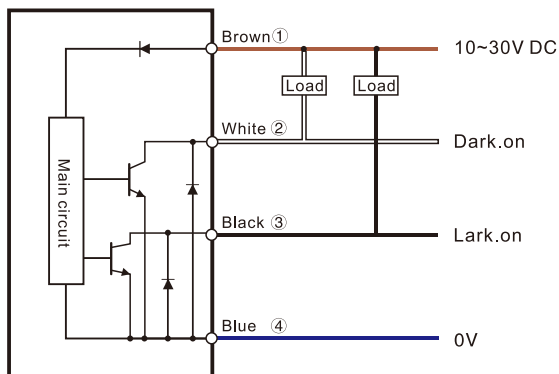

PNP Output

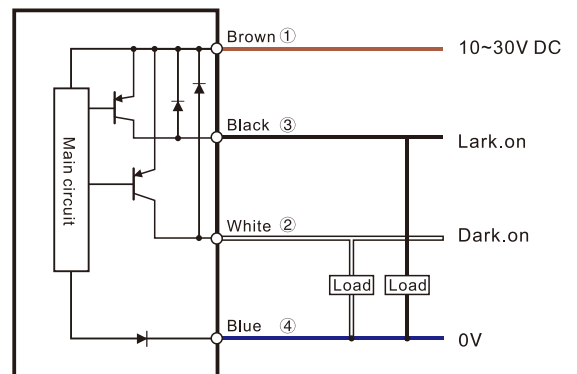



Economical Type

Appearance

Sensing type	Diffuse reflection		Convergent reflective	Retro-reflection			
Sensing distance	10–300mm	5–1000mm	5–140mm	10–200mm	2m	3m	
Spot size	≈ φ 16mm / 300mm	≈ φ 50mm / 1000mm	≈ φ 9mm / 140mm	φ 10mm / 20cm	φ 50mm / 2m	φ 90mm / 3m	
Output type	NPN or PNP open collector, ≤100mA (30V DC)						
Switch type	L.on / D.on Switchable						
Indicator	Motion indicator: Red ; Operating indicator: Green						
Response time	<1ms		1ms	<1ms			
Sensitivity adjustment	Single-turn potentiometer						
Light source	Red light LED 623 nm (modulated)						
Operating voltage	10–30V DC						
Current consumption	≤25mA			≤20mA			
Ambient illuminance	Sunlight ≤ 10000 Lux; Incandescent Lamp ≤ 3000 Lux						
Ambient temperature	–25°C~+55°C, No freezing						
Ambient humidity	35%~85%RH, No condensation						
Anti-vibration	10 ~ 50Hz, 0.5mm amplitude, 2 hours each in X, Y, Z directions						
Circuit protection	Power reverse polarity protection, output reverse polarity protection, surge protection, short circuit protection						
Degree of protection	IP65						
Connection method	2M/3 cores cable, φ 4mm						
Material	PBT+Fiberglass (Housing) , PMMA (Lens)						
Accessories	Screwdriver		Screwdriver, reflective sticker	Screwdriver, reflector			
Model No.	NPN	PTE-D30N	PTE-D70N	PTE-X09N	PTE-R20N	PTE-R200N	PTE-R300N
	PNP	PTE-D30P	PTE-D70P	PTE-X09P	PTE-R20P	PTE-R200P	PTE-R300P

Dimensions

Unit: mm

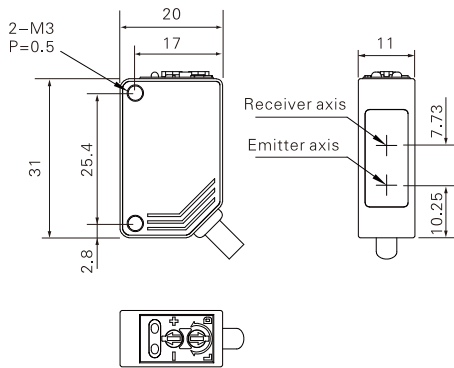

Reflector for PTE-R200

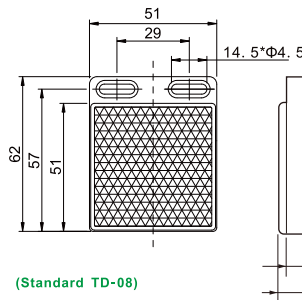

Reflector for PTE-R300

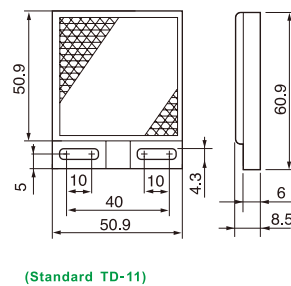

PTE-R20 Reflective Stickers

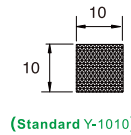

Circuit diagram

NPN Output

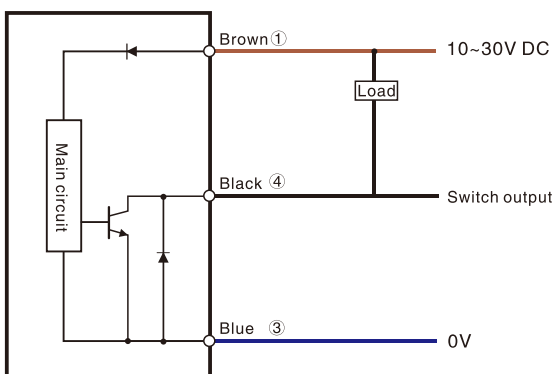

PNP Output

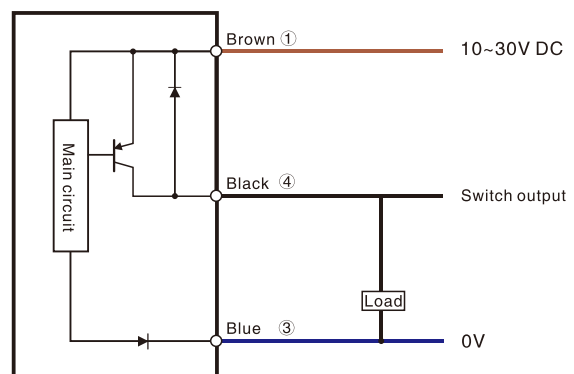

- Fiber Optic
- Slot Sensors
- Photoelectric**
- Laser
- Proximity
- Displacement
- Magnetic
- Contact
- Area
- Ultrasonic
- Vision
- Code Readers
- Vibration
- Temperature
- Accessories

Guidance

Photoelectric

- Cylindrical
- Square**
- Flat type
- Thin type
- BGS
- Transparent detection
- Color/Mark Detection
- TOF type
- IP59K high protection type
- Anti-glare type
- IO-Link type

Reflectors

- Reflectors

Square

PTE Series



Economical Type

Appearance			
Sensing type	Thru-beam Reflection		
Sensing distance	10m		
Detected object	$\phi > 12\text{mm}$, opaque		
Output type	NPN / PNP open collector		
Switch Type	L.on/D.on selectable		L.on/D.on switchable
Indicator	Status indicator: green, output indicator: red		Emitter: Power: green; Receiver: Operation: green, Motion: red
Response time	33ms		
Sensitivity	Not adjustable		Single turn potentiometer
Light source	IR LED 623nm (modulated)		
Operating voltage	10~30V DC		
Current consumption	Emitter $\leq 20\text{mA}$; Receiver $\leq 20\text{mA}$		
Ambient illuminance	Sunlight $\leq 10,000$ Lux, Incandescent lamp $\leq 3,000$ Lux		
Ambient temperature	$-25^{\circ}\text{C} \sim +55^{\circ}\text{C}$, No freezing		
Ambient humidity	35%~85% RH, No condensation		
Anti-vibration	10 to 50 Hz with 0.5mm amplitude for 2 hours each in X, Y, and Z directions		
Circuit protection	Power reverse polarity protection, short circuit protection		
Degree of protection	IP65		
Connection	2M / 3 cores cable 4mm diameter		
Material	Fiberglass (housing), PMMA(lens)		
Accessories	Screwdriver		
Model No.	NPN	PTE-TM10NO	PTE-TM10NC
	PNP	PTE-TM10PO	PTE-TM10PC
			PTE-TM10AN
			PTE-TM10AP

Dimensions

Unit: mm

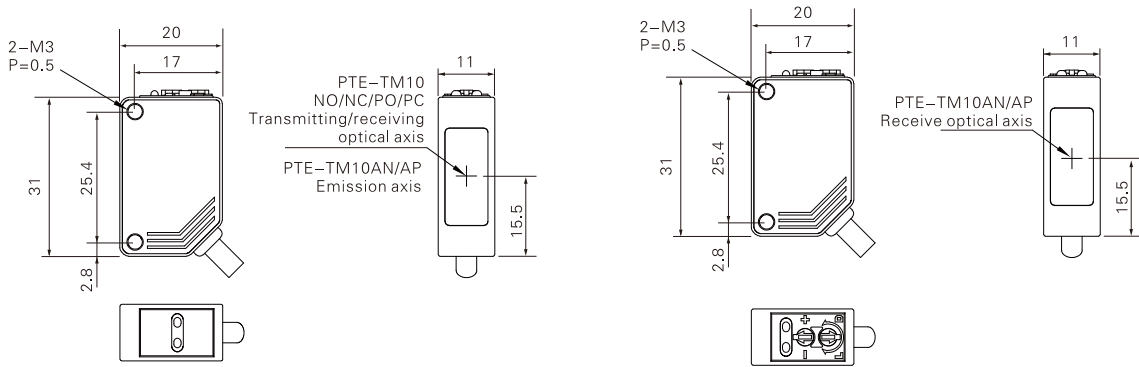

Circuit diagram

NPN Output

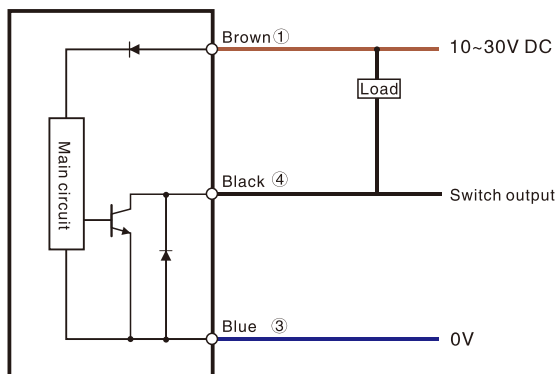

PNP Output

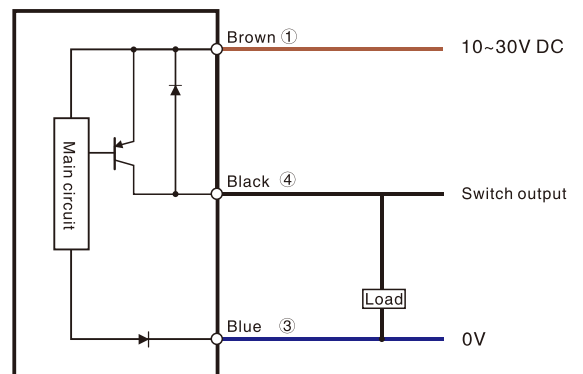



Wide Facula Type

Appearance			
Sensing type	Disffuse refection		
Sensing distance	5-200mm	10cm	20cm
Spot diameter	130*130mm/20cm	-	-
Output type	NPN / PNP open collector		
Switch type	L.on /D.on selectable		
Indicator	Operation indicator: Green, Motion indicator: Red		
Response time	1ms		
Sensitivity	Single-turn potentiometer		
Light source	Red LED 623nm (modulation)	Infrared LED 940nm (modulation)	
Operating voltage	10~30V DC		
Current consumption	<25mA	≤20mA	
Load current	<100mA	≤100mA	
Ambient illuminance	Sunlight ≤10000Lux, Incandescent lamp ≤3000Lux		
Ambient temperature	-25℃~+55℃, No freezing		
Ambient humidity	35%~85%RH, No condensation		
Anti-vibration	10 to 50 Hz with 0.5mm amplitude for 2 hours each in X, Y, and Z directions		
Circuit protection	Power reverse polarity protection, output reverse polarity protection, surge protection, short circuit protection		
Degree of protection	IP65		
Connection	2M 3 core cable, φ 4mm		
Material	PBT+Fiberglass (body), PMMA(lens)		
Accessories	Screwdriver		
Model No.	NPN	PTEW-D20N	PTVW-D10N
	PNP	PTEW-D20P	PTVW-D10P
			PTVW-D20N
			PTVW-D20P

Dimensions

Unit: mm

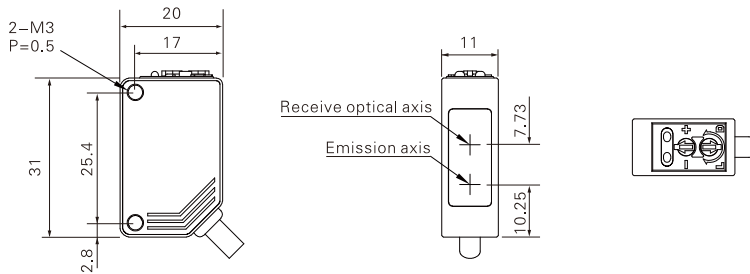

Circuit diagram

NPN Output

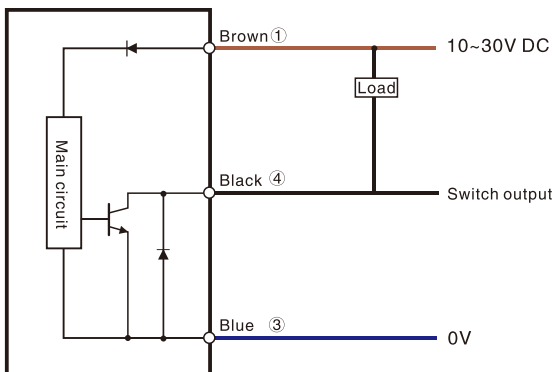

PNP Output

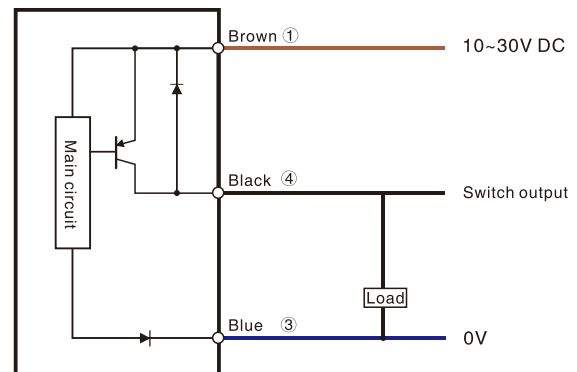

- Fiber Optic
- Slot Sensors
- Photoelectric**
- Laser
- Proximity
- Displacement
- Magnetic
- Contact
- Area
- Ultrasonic
- Vision
- Code Readers
- Vibration
- Temperature
- Accessories

Guidance

- Photoelectric
- Cylindrical
- Square**
- Flat type
- Thin type
- BGS
- Transparent detection
- Color/Mark Detection
- TOF type
- IP69K high protection type
- Anti-glare type
- IO-Link type

Reflectors

- Reflectors

Anti-glare Type

PTL Series



Appearance		
Sensing type	Diffuse reflection-BGS	
Sensing distance	5~100mm	10~300mm
Setting distance	20~100mm	50~300mm
Spot diameter	≈ Ø10mm/100mm	≈ Ø30mm/300mm
Hysteresis	≦3%	≦5%
Output type	NPN / PNP open collector	
Switch type	L.on/D.on selectable	
Indicator	Operating indicator: orange, Status indicator: green	
Response time	≦1ms	
Sensitivity	6-turn potentiometer	4-turn potentiometer
Light source	Red LED	
Operating voltage	10~30V DC	
Current consumption	≦30mA	
Load current	≦100mA	
Ambient illuminance	Sunlight ≦ 50,000 Lux, Incandescent lamp ≦ 5,000 Lux	
Ambient temperature	-25°C~+55°C, No freezing	
Ambient humidity	35%~85%RH, No condensation	
Anti-vibration	10 to 50 Hz with 0.5mm amplitude for 2 hours each in X, Y, and Z directions	
Degree of protection	IP67	
Connection	ABS (body), PMMA (lens)	
Accessories	Screwdriver	
Model No.	NPN PTL-D10N	PTL-D30N
	PNP PTL-D10P	PTL-D30P

Dimensions

Unit: mm

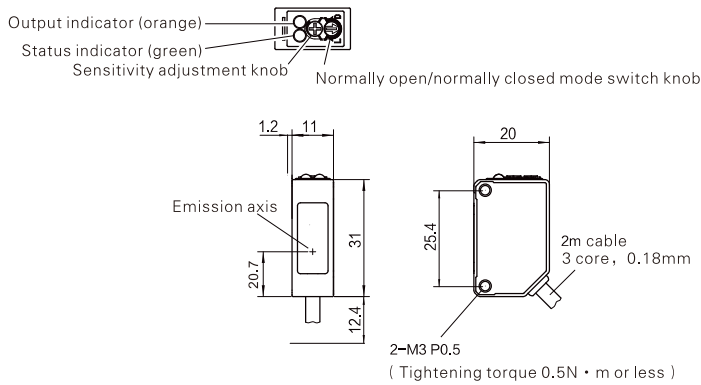

Circuit diagram

NPN Output

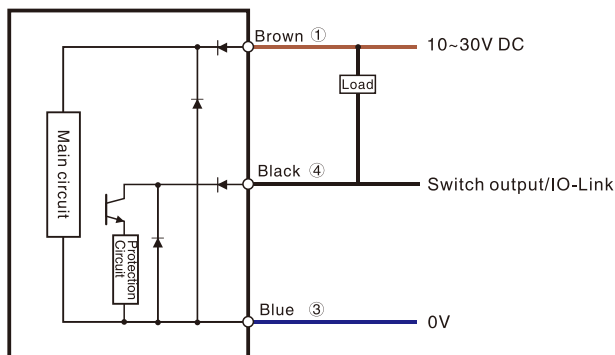

PNP Output

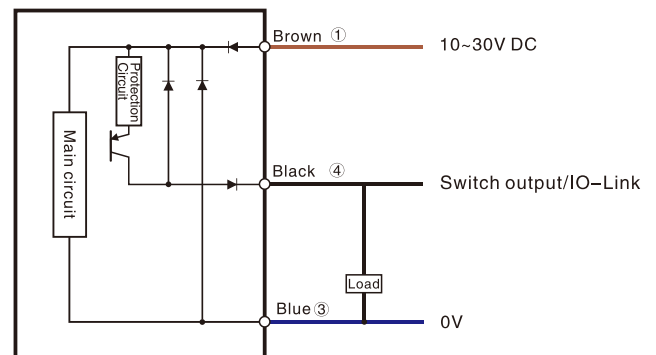



Appearance

Sensing type	Diffuse reflection		Convergent reflective	
Sensing distance	10–300mm	5–1000mm	5–140mm	
Output type	NPN/PNP Open-collector			
Switch type	Selectable L.on/D.on			
Response time	< 1ms			
Light source	Infrared LED(940nm modulation)			
Operating voltage	10~30V DC			
No-load supply current	< 25mA			
Load current	< 100mA			
Ambient temperature	-25°C~+55°C, No freezing			
Ambient humidity	35%~85% RH, No condensation			
Circuit protection	Power reverse polarity, output reverse polarity, surge, short circuit			
Degree of protection	IP65			
Material	PBT+Fiberglass (Housing) , PMMA (Lens)			
Connection method	2M 3core cable			
Weight	≈ 50g			
Accessories	Screwdriver			
Model No.	NPN	PTV-D30N HOT	PTV-D70N	PTV-X09N
	PNP	PTV-D30P	PTV-D70P	PTV-X09P

Dimensions

Unit: mm

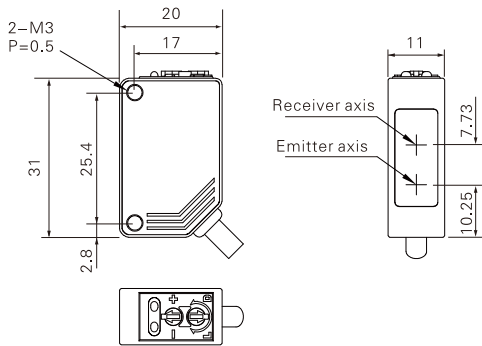

Circuit diagram

NPN Output

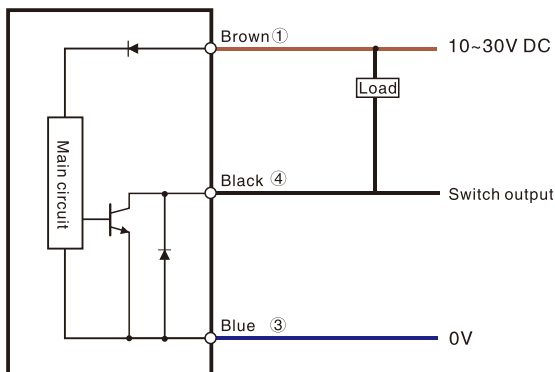

PNP Output

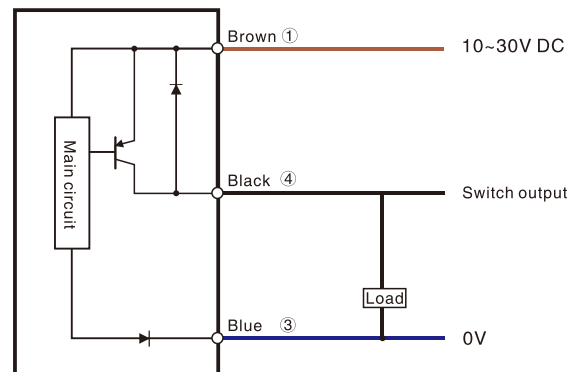

- Fiber Optic
- Slot Sensors
- Photoelectric**
- Laser
- Proximity
- Displacement
- Magnetic
- Contact
- Area
- Ultrasonic
- Vision
- Code Readers
- Vibration
- Temperature
- Accessories

Guidance

Photoelectric

- Cylindrical
- Square**
- Flat type
- Thin type
- BGS
- Transparent detection
- Color/Mark Detection
- TOF type
- IP69K high protection type
- Anti-glare type
- IO-Link type

Reflectors

- Reflectors

Square

PTV Series



Appearance

Sensing type	Thru-beam				
Sensing distance	20m(fixed)	20m	5m		
Output type	NPN/PNP Open-collector				
Switch type	Selectable L.on/D.on, Model optional		Selectable L.on/D.on		
Response time	< 5ms				
Light source	Infrared LED(940nm modulation)				
Operating voltage	10~30V DC				
No-load supply current	Transmitter: <20mA; Receiver end: <20mA				
Load current	<100mA				
Ambient temperature	-25°C~+55°C, No freezing				
Ambient humidity	35%~85%RH, No condensation				
Circuit protection	Power reverse polarity,output reverse polarity,surge,short circuit				
Degree of protection	IP65				
Material	PBT+Fiberglass (Housing) , PMMA (Lens)				
Connection method	2M 3core cable				
Weight	≈50g				
Accessories	Screwdriver				
Model No.	NPN	PTV-TM20NO	PTV-TM20NC	PTV-TM20AN	PTV-T500N
	PNP	PTV-TM20PO	PTV-TM20PC	PTV-TM20AP	PTV-T500P

Dimensions

Unit: mm

PTV-TM20NO/PO/NC/PC

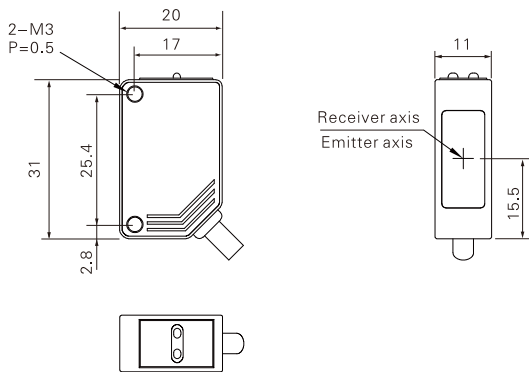

PTV-TM20AN/AP、PTV-T500N/P

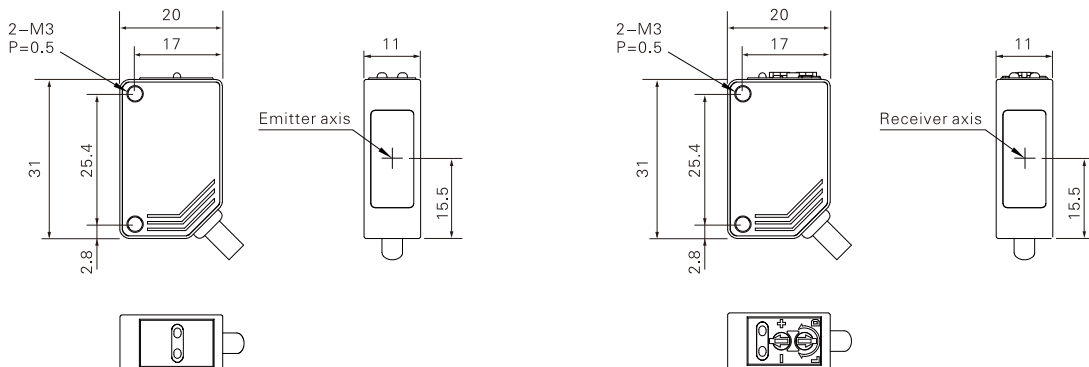

NPN Output

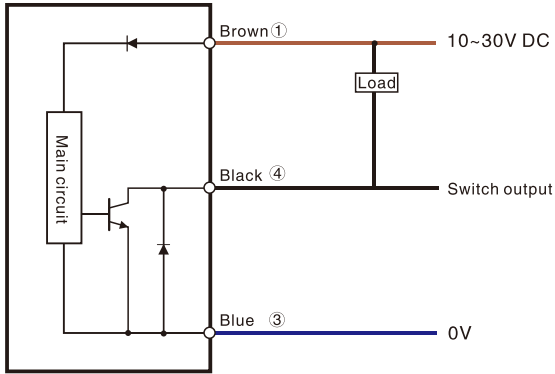

PNP Output

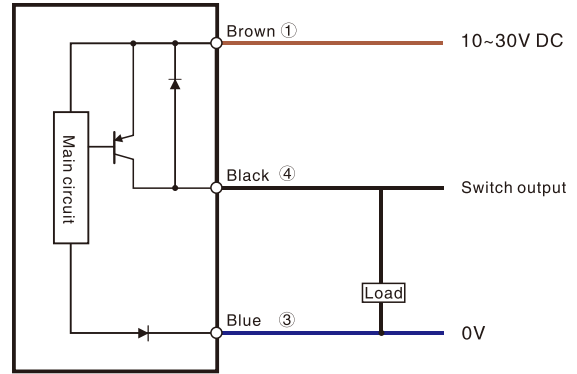

- Fiber Optic
- Slot Sensors
- Photoelectric**
- Laser
- Proximity
- Displacement
- Magnetic
- Contact
- Area
- Ultrasonic
- Vision
- Code Readers
- Vibration
- Temperature
- Accessories

Guidance

Photoelectric

- Cylindrical
- Square**
- Flat type
- Thin type
- BGS
- Transparent detection
- Color/Mark Detection
- TOF type
- IP69K high protection type
- Anti-glare type
- IO-Link type

Reflectors

- Reflectors



IO-Link

Appearance

Sensing type	Diffuse reflection	Thru-beam reflection	Retro-reflection	
Sensing distance	0~1m(white paper200X200mm)	0~25m	0.01~4m(with reflector)	
Spot diameter	φ 75mm / 1m	φ 1800mm / 25m	φ 280mm / 4m	
Output type	NPN/PNP Open-collector			
Switch type	L.on/D.on selectable			
Indicator	Input indicator: orange, Status indicator: green			
Response time	≤500us			
Sensitivity	Single turn adjuster			
Light source	Red light LED			
Operating voltage	10~30V DC ± 10%			
Current consumption	<20mA	Emitter<14mA, Receiver<20mA	<20mA	
Load current	≤100mA			
Hysteresis	≤20%		-	
Function	IO-LINK			
Ambient illuminance	Sunlight≤5000Lux, Incandescent lamp≤5000Lux			
Ambient temperature	-25°C~+55°C, no freezing			
Ambient humidity	35%~85%RH, No condensation			
Degree of protection	IP67			
Connection	2m 3 core cable(2m 2 core cable for thru-beam models)			
Material	ABS (housing) +PMMA (lens)			
Accessories	-			
Model No.	NPN	PTZ-D70N-C	PTZ-TM25N-C	PTZ-R400N-C
	PNP	PTZ-D70P-C	PTZ-TM25P-C	PTZ-R400P-C

Guidance

Dimensions

Unit: mm

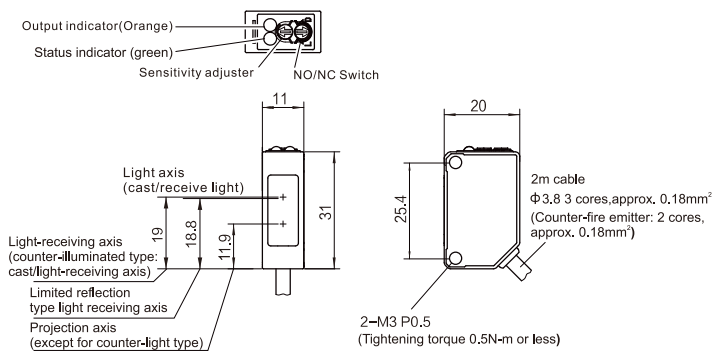

Reflector for PTZ-R400-C

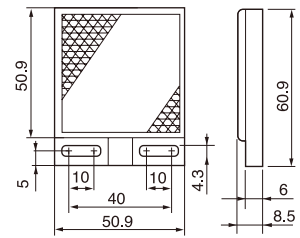

NPN Output

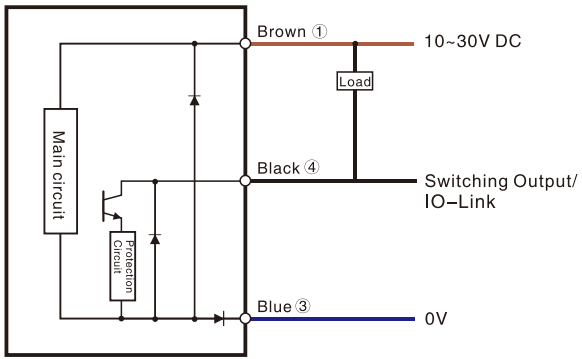

PNP Output

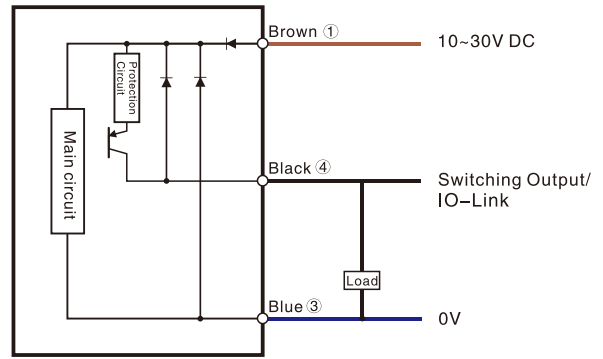

Thru-beam Emitter

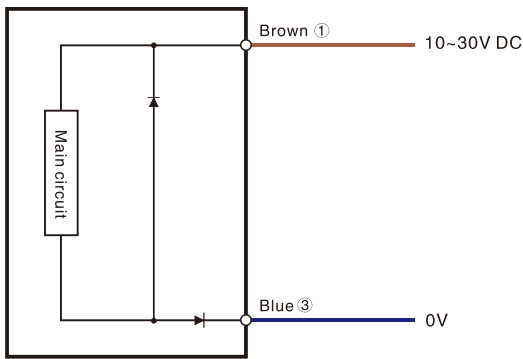

- Fiber Optic
- Slot Sensors
- Photoelectric**
- Laser
- Proximity
- Displacement
- Magnetic
- Contact
- Area
- Ultrasonic
- Vision
- Code Readers
- Vibration
- Temperature
- Accessories

Guidance

Photoelectric

- Cylindrical
- Square
- Flat type
- Thin type
- BGS
- Transparent detection
- Color/Mark Detection
- TOF type
- IP69K high protection type
- Anti-glare type
- IO-Link type**

Reflectors

- Reflectors

Square

PTN Series



Appearance

Sensing type	Diffuse reflection	Thru-beam
Sensing distance	5cm, White board 100*100mm (> 5cm)	50cm
Output type	NPN/PNP Open-collector	
Switch type	L.on	D.on
Response time	≤ 1 ms	
Light source	Infrared LED (940nm)	
Operating voltage	12~24V DC ± 10%	
Current consumption	≤ 20mA	≤ 30mA
Load current	≤ 100mA (24V DC)	
Circuit protection	Reverse polarity protection, short circuit protection	
Ambient temperature	-10°C~+45°C, No freezing	
Ambient humidity	35%~85% RH, No condensation	
Storage temperature	-10°C~+55°C, No freezing	
Storage humidity	35%~95% RH, No condensation	
Withstand voltage	1000 V/AC 50/60Hz 1min	
Insulation resistance	≥ 20MΩ/500V DC	
Degree of protection	IP64	
Material	ABS	
Connection method	φ 2.4*2M 3core cable	(Receiver) φ 2.4*2M 3core cable/ (Emitter) φ 2.4*2M 3core cable
Weight	≈ 20g	≈ 40g
Accessories	Mounting screws	
Model No.	NPN	PTN-D05N
	PNP	PTN-D05P
		PTN-T50N
		PTN-T50P

Dimensions

Unit: mm

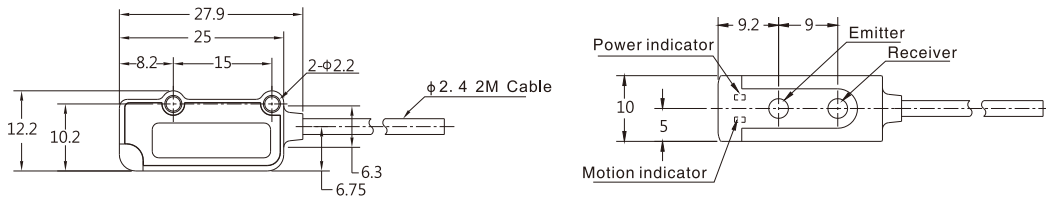

Circuit diagram

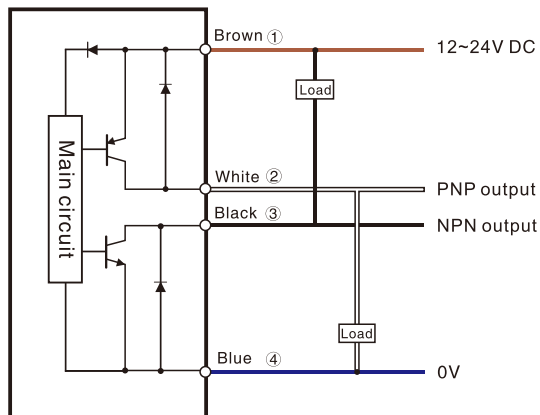



Appearance			
Sensing type	Thru-beam		
Sensing distance	80cm (fixed)	150cm (fixed)	
Detected object	Opaque objects above $\phi 6\text{mm}$		
Output type	NPN/PNP Open-collector		
Switch type	Selectable L.on/D.on, Model optional		
Response time	33ms		
Indicator	Transmitter: Power indicator: green; Receiver: Action indicator: yellow		
Light source	Infrared LED 850nm (Modulated)		
Operating voltage	12~24V DC		
Residual voltage	2V or less (when the current is 50mA)		
Current consumption	The transmitting end < 20mA, Receiving end < 20mA		
Load current	< 50mA		
Circuit protection	Reverse polarity , short circuit		
Ambient illuminance	Sunlight $\leq 10000\text{Lux}$, Incandescent lamp $\leq 3000\text{Lux}$		
Ambient temperature	$-20^{\circ}\text{C}\sim+50^{\circ}\text{C}$, No freezing		
Voltage drop	35~90% RH, Storage: 35~90% RH		
Storage temperature	$-30^{\circ}\text{C}\sim+70^{\circ}\text{C}$, No freezing		
Withstand voltage	$\geq 20\text{M}\Omega/500\text{V DC}$		
Pressure strength	AC1000V(50/60Hz)1minute		
Shock resistance	10~55Hz reciprocating amplitude 1.5mm, X, Y, Z directions 2 hours		
Impact resistant	500m/s ² XYZ three directions		
Degree of protection	IP 64		
Housing Material	PC/ABS		
Connection method	2M 3core cable		
Accessories	-		
Model No.	NPN D.on	PTJ-T80NO-I	PTJ-T150NO-I
	NPN L.on	PTJ-T80NC-I	PTJ-T150NC-I
	PNP D.on	PTJ-T80PO-I	PTJ-T150PO-I
	PNP L.on	PTJ-T80PC-I	PTJ-T150PC-I

- Fiber Optic
- Slot Sensors
- Photoelectric**
- Laser
- Proximity
- Displacement
- Magnetic
- Contact
- Area
- Ultrasonic
- Vision
- Code Readers
- Vibration
- Temperature
- Accessories

Guidance

Photoelectric

Cylindrical

Square

Flat type

Thin type

BGS

Transparent detection

Color/Mark Detection

TOF type

IP59K high protection type

Anti-glare type

IO-Link type

Reflectors

Reflectors

Dimensions

Unit: mm

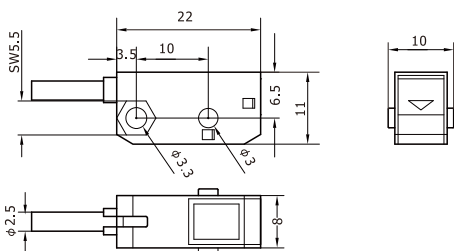

Circuit diagram

NPN Output

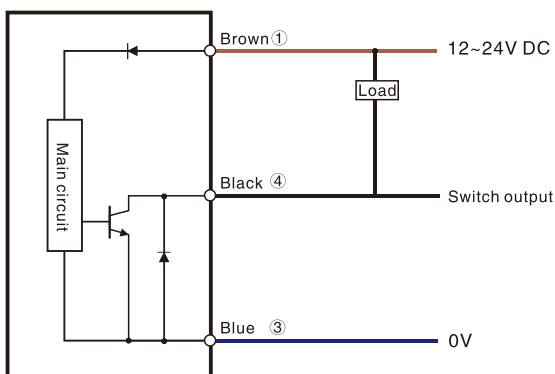

PNP Output

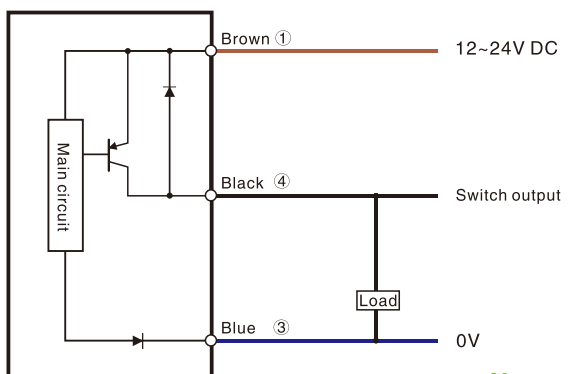

TOF Type

PX Series



TOF Type
NEW!

Appearance		
Sensing type	TOF (Time of flight) 1 point teaching	
Sensing distance	100cm	300cm
Setting range	5 ~ 100cm (White paper 200 × 200mm)	20 ~ 300cm (White paper 200 × 200mm)
Light source	Infrared LED (940nm)	Infrared LED (850nm)
Detected object	above 200*200mm	above 200*200mm
Output	NPN/PNP Open-collector	
Sensitivity adjustment	Tech-in	
Indicators	Power: green, output indicator: red, When the teaching is successful: the green light flashes and then keeps on; when the teaching fails: the red and green lights flash alternately for 6s	
Response time	< 30 ms	< 100 ms
Hysteresis	Range 5~10cm, hysteresis < 1cm; Range 10~100cm, hysteresis < 10%	Range 20~50 cm, hysteresis < 4cm; Range 50~300 cm, hysteresis < 10%
Repeatability	Range 5~10cm, hysteresis < 0.5cm; Range 10~100cm, hysteresis < 5 %	< 1.5 cm
Operating voltage	12~24V DC ± 10%	
Residual voltage	< 1.5 V (load current < 125mA)	
Current consumption	≤ 30mA	≤ 25mA
Load current	≤ 100mA (24V DC)	
Circuit protection	reverse polarity protection, short circuit protection	
Ambient temperature	Operation temperature: -10°C~60°C, no freezing; storage temperature: -20°C~70°C	
Ambient humidity	Working: 35~90% RH ; storage: 35~90% RH, no condensation	
Withstand voltage	± 1000V 50/60Hz 60s	
Static electricity	± 4000V(Contact discharge)	
Group pulse	± 2000V/5kHz/100kHz	
Anti-vibration	10~50Hz, amplitude 0.5mm; 2 hours each in X, Y, Z directions	
Ambient light	Incandescent light ≤ 5,000Lux	
Material	Aluminum alloy	
Connection	φ = 4mm, 2m 3 wire cable	
Model No.	NPN PX-F09N PNP PX-F09P	PX-F30N PX-F30P

Dimensions

Unit: mm

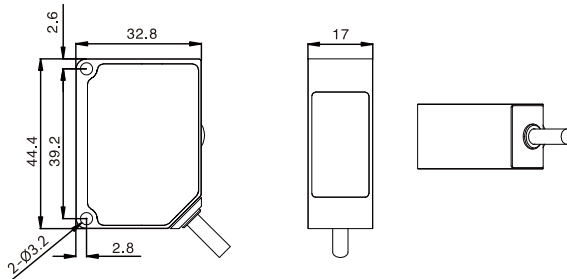

Circuit diagram

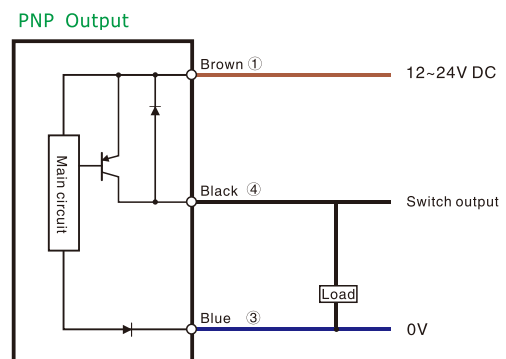
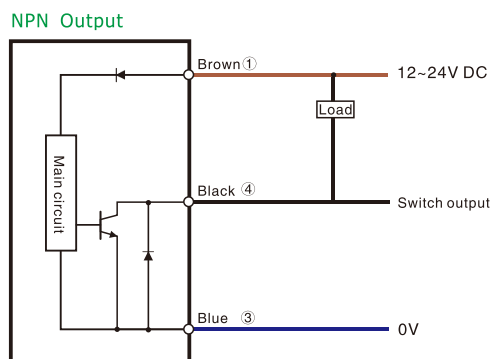



Appearance	Front	Head		
Detection surface	Diffuse reflection			
Sensing type	2.5~8mm(black object 3mm)			
Sensing distance	<20%			
Hysteresis	Infrared LED(880nm)			
Light source	<1ms			
Response time	12~24V DC			
Operating voltage	<2.5V (load current is 100mA)			
Voltage drop	Below 3V (load current 100mA/ 2m cable)			
Residual voltage	Red LED			
Indicator	L,on/D,on model selectable			
Switch type	Surge protection, reverse polarity protection			
Circuit protection	Operation: -10°C~55°C, Storage: -25°C~80°C(No freezing)			
Storage temperature	Operation: 45%~85% RH, Storage: 35%~90% RH (No condensation)			
Storage humidity	≤3500Lux			
Ambient illuminance	When the rated power supply voltage range fluctuates within ± 15%, the sensing distance will be changed within ± 1%.			
Voltage influence	> 50MΩ/500V DC			
Insulation resistance	AC1000V, 50/60Hz, 1min			
Withstand voltage	10~55Hz, Upper and lower amplitude 1.5mm, 2 hours in X, Y, Z direction			
Vibration resistance	500m/s ² 10 times in X,Y,Z			
Impact resistance	IP50			
Degree of protection	PC			
Housing Material	2m 3 core cable			
Connection method	-			
Accessories				
Model No.	NPN	Dark.on	MP2-410N-WD	MP2-412N-WD
		Light.on	MP2-410N-WL	MP2-412N-WL
	PNP	Dark.on	MP2-410P-WD	MP2-412P-WD
		Light.on	MP2-410P-WL	MP2-412P-WL

- Fiber Optic
- Slot Sensors
- Photoelectric**
- Laser
- Proximity
- Displacement
- Magnetic
- Contact
- Area
- Ultrasonic
- Vision
- Code Readers
- Vibration
- Temperature
- Accessories

Guidance

Photoelectric

- Cylindrical
- Square
- Flat type**
- Thin type
- BGS
- Transparent detection
- Color/Mark Detection
- TOF type
- IP69K high protection type
- Anti-glare type
- IO-Link type

Reflectors

- Reflectors

Dimensions

MP2-410□-WD

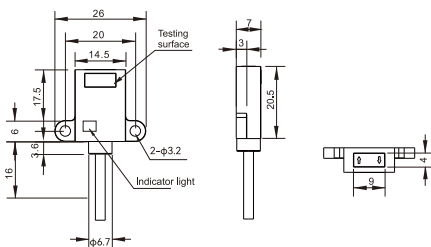

MP2-412□-WD

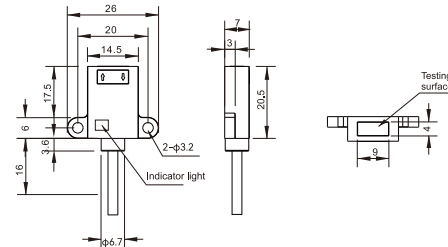

Unit: mm

Circuit diagram

NPN Output

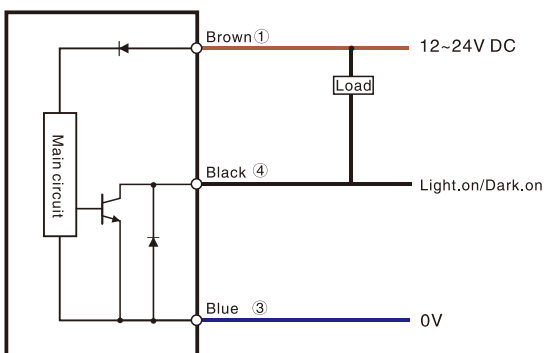

PNP Output

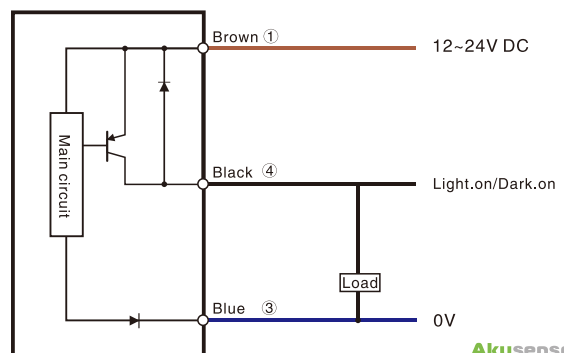

Flat Type

MP2 Series Connector Type

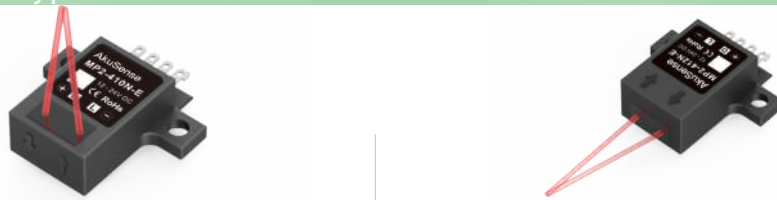

Appearance	Front	Head	
Detection surface	Front	Head	
Sensing type	Diffuse reflection		
Sensing distance	40mm (50 x 50 white matte paper)		
Hysteresis	< 20%		
Output type	NPN/PNP Open-collector		
Switch type	Selectable L.on/D.on		
Response time	< 1 ms		
Light source	Infrared LED (850nm)		
Operating voltage	12~24V DC		
Current consumption	< 20mA	< 25mA	
Voltage drop	< 2.5V (load current is 100mA)		
Load current	< 100mA(24V DC)		
Withstand voltage	AC 1000V 50/60Hz 1min		
Ambient temperature	Operation: -20°C~+55°C, Storage: -25°C~+80°C(No freezing)		
Ambient humidity	Operation: 45%~+85%RH, Storage: 35%~90%RH (No condensation)		
Insulation resistance	> 20MΩ/500V DC		
Ambient illuminance	Incandescent lamp ≦ 3000Lux, Sunlight ≦ 10000Lux		
Degree of protection	IP50		
Material	PC		
Connection method	connector		
Accessories	Mounting screws		
Model No.	NPN	MP2-410N-E HOT	MP2-412N-E
	PNP	MP2-410P-E	MP2-412P-E

Dimensions

Unit: mm

MP2-410N(P)-E

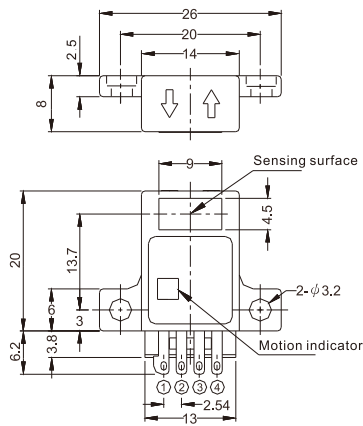

MP2-412N(P)-E

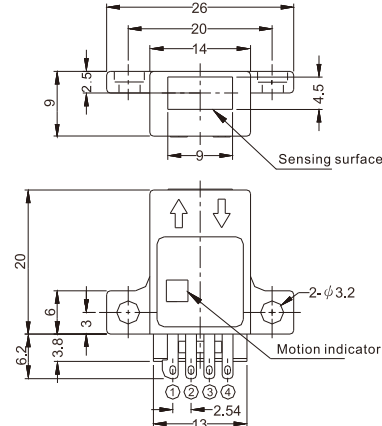

- ①: ○ Brown
- ②: ○ OUT1 White
- ③: ○ OUT2 Black
- ④: ○ Blue

Connection cable: ME-1007 (To O-11)

Circuit diagram

NPN Output

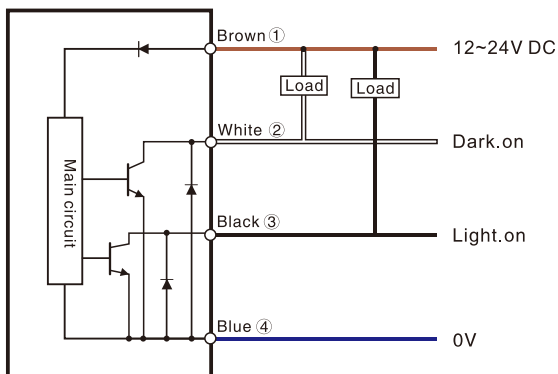

PNP Output

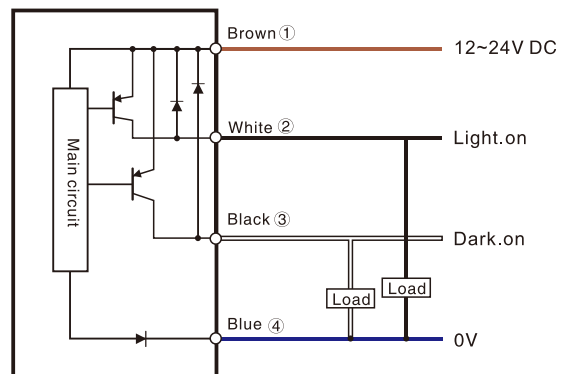



Sensing type	Convergent reflective		Thru beam						
Sensing distance	2~15mm	2~25 mm (fixed)	500mm (fixed)	1m (fixed)					
Light source	Infrared light 850nm (modulated)	Infrared light 950nm (Modulated)	Infrared light	Red light					
Detectable object	all objects	50*50mm white paper	Opaque, $\phi > 2$ mm						
Output	NPN/PNP Open-collector, ≤ 100 mA								
Switch type	L.on								
Indicator	Motion indicator: orange; Power: green								
Response time	1.2ms	≤ 1.2 ms							
Power-up delay	50ms		-						
Operating voltage	10~30V DC $\pm 10\%$								
Residual voltage	< 2 V (load current < 50 mA)								
Current consumption	≤ 20 mA								
Load current	< 100 mA	< 50 mA							
Circuit protection	Overload protection/reverse connection protection/short circuit protection	Reverse polarity protection/surge protection/short circuit protection							
Ambient illuminance	Sunlight $\leq 10,000$ Lux, Incandescent lamp $\leq 3,000$ Lux								
Ambient temperature	Working: $-25^{\circ}\text{C} \sim +55^{\circ}\text{C}$, no freezing; storage: $-10^{\circ}\text{C} \sim +55^{\circ}\text{C}$								
Ambient humidity	Working: 35%~85%RH; Storage: 35%~95%RH, no condensation								
Withstand voltage	± 500 V 50/60Hz 60s								
Static electricity	± 8000 V								
Group pulse	± 2000 V (5kHz/50kHz/100kHz)								
Anti-vibration	10~55Hz, amplitude 1.5mm, 2 hours each in X, Y, Z directions	10~50Hz, 0.5mm amplitude, 2 hours each in X, Y, Z directions							
Degree of protection	IP67								
Connection	$\phi 2.5$ * 2M /3 core cable								
Material	PC								
Accessories	Mounting screws								
Model No.	NPN	ESL-15NO	ESL-15NC	ESL-25NO	ESL-25NC	ESL-T50NO	ESL-T50NC	ESL-TM01NO	ESL-TM01NC
	PNP	ESL-15PO	ESL-15PC	ESL-25PO	ESL-25PC	ESL-T50PO	ESL-T50PC	ESL-TM01PO	ESL-TM01PC

- Fiber Optic
- Slot Sensors
- Photoelectric**
- Laser
- Proximity
- Displacement
- Magnetic
- Contact
- Area
- Ultrasonic
- Vision
- Code Readers
- Vibration
- Temperature
- Accessories

Guidance

Photoelectric

- Cylindrical
- Square
- Flat type
- Thin type**
- BGS
- Transparent detection
- Color/Mark Detection
- TOF type
- IP69K high protection type
- Anti-glare type
- IO-Link type

Reflectors

- Reflectors

Dimensions

Unit: mm

ESL-15

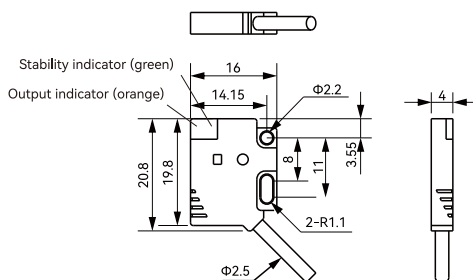

ESL-25

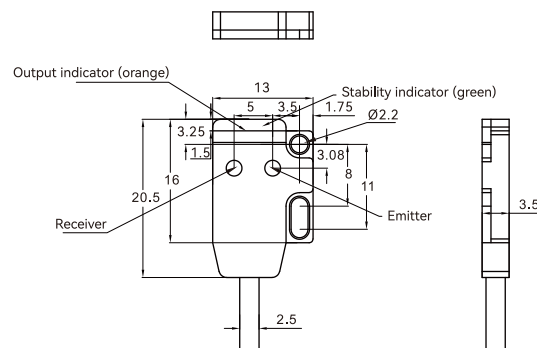

ESL-T50/TM01

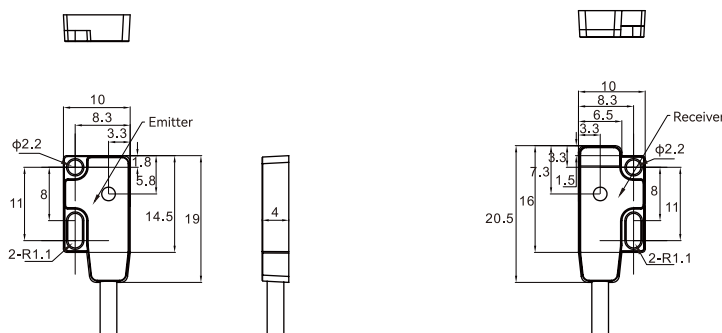

Thin Type

Circuit diagram

NPN Output

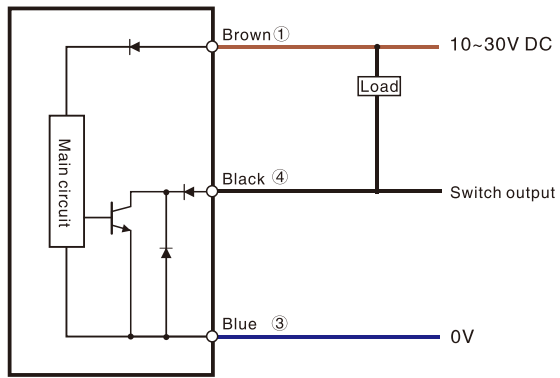

PNP Output

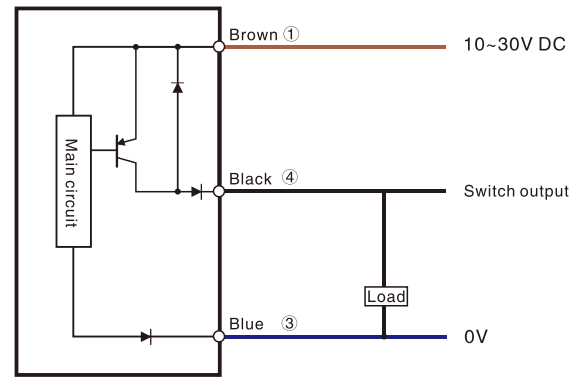

Fiber Optic

Slot Sensors

Photoelectric

Laser

Proximity

Displacement

Magnetic

Contact

Area

Ultrasonic

Vision

Code Readers

Vibration

Temperature

Accessories

Guidance

Photoelectric

Cylindrical

Square

Flat type

Thin type

BGS

Transparent detection

Color/Mark Detection

TOF type

IP69K high protection type

Anti-glare type

IO-Link type

Reflectors

Reflectors



Appearance			
Sensing type	Disffuse refection-BGS		
Sensing distance	5 ~ 100mm(White non-glossy paper)	5mm ~ 150mm(White non-glossy paper)	0 ~ 300mm (White non-glossy paper)
Setting distance	30 ~ 100mm	40 ~ 150mm	40 ~ 300mm
Spot size	≈ Ø1.5mm/10cm	≈ Ø9mm/15cm	≈ Ø16mm/30cm
Hysteresis	≤5%	≤20%	≤5%
Output type	NPN/PNP Open-collector, ≤100mA/30V DC		
Switch type	L.on/D.on selectable		
Indicator	Operation indicator: Green Motion indicator: Red		
Response time	≤2ms	5ms	≤2ms
Sensitivity adjustment	Adjuster(6 turns)	Adjuster (single turns)	Adjuster(6 turns)
Light source	Red LED small spot 623nm (modulation)	Red LED 623nm (modulation)	
Operating voltage	10~30V DC ± 10%	10~24V DC ± 10%	10~30V DC ± 10%
Current consumption	<20mA		<25mA
Load current	<100mA		
Ambient illuminance	Sunlight ≤5,000Lux, Incandescent lamp ≤3,000Lux		
Ambient temperature	-25℃~55℃ no freezing		
Ambient humidity	35~85%RH, No condensation		
Degree of protection	IP65		
Connection method	2M/3 core cable		
Material	PBT+fiberglass(body); PMMA(Lens)		
Accessories	Screwdriver		
Model No.	NPN	ESB-S10N	ESB-15N
	PNP	ESB-S10P	ESB-15P
			ESB-30N
			ESB-30P

Dimensions

Unit: mm

ESB-S10/15N(P)

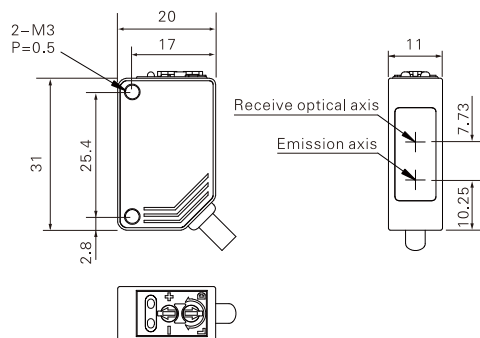

ESB-30N(P)

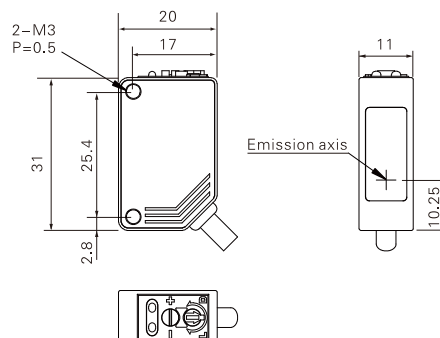

ESB-S10/15/30N(P)

NPN Output

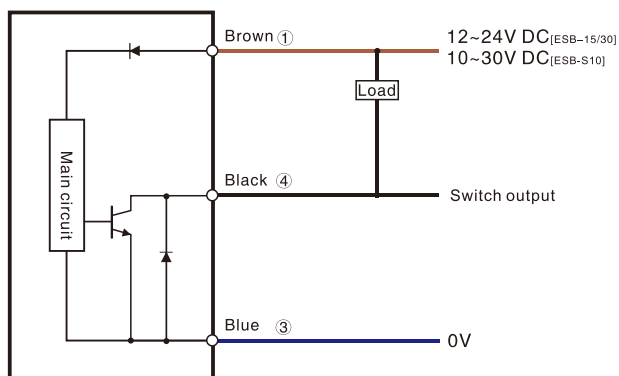

PNP Output

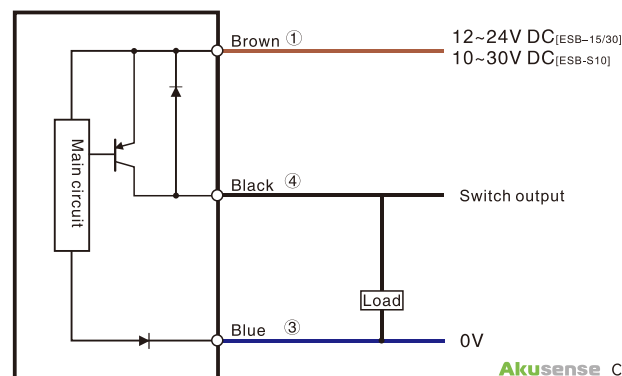

- Fiber Optic
- Slot Sensors
- Photoelectric**
- Laser
- Proximity
- Displacement
- Magnetic
- Contact
- Area
- Ultrasonic
- Vision
- Code Readers
- Vibration
- Temperature
- Accessories

Guidance

Photoelectric

- Cylindrical
- Square
- Flat type
- Thin type
- BGS**
- Transparent detection
- Color/Mark Detection
- TOF type
- IP69K high protection type
- Anti-glare type
- IO-Link type

Reflectors

- Reflectors



NEW!

Sensing type	Diffuse reflective – Background suppression	
Sensing distance	10 ~ 300mm	10 ~ 200mm
Setting distance	40 ~ 300mm	40 ~ 200mm
Spot size	-	≈ ∅12mm/200mm
Hysteresis	≤ 5%	
Output	NPN/PNP Open – collector	
Switch type	L.on /D.on switchable	
Indicators	Power: green; motion indicator: red	
Response time	≤ 2ms	
Sensitivity adjustment	6 turns adjuster	
Light source	Infrared LED 940nm (modulation)	Red LED 623nm (modulation)
Supply voltage	10~30V DC ± 10%	
Residual voltage	< 1.5V	
Current consumption	≤ 25mA	
Load current	≤ 100mA	
Circuit protection	Power reverse polarity protection/surge protection/short circuit protection	
Ambient illuminance	Sunlight ≤ 5,000 lux, incandescent lamp ≤ 3,000 lux	
Ambient temperature	Working temperature: -25°C~+55°C, no freezing; storage: -30 ~ +70°C	
Ambient humidity	Working: 35%~85%RH; storage: 35%~95%RH,; no condensation	
Insulation resistance	20MΩ	
Withstand voltage	± 1000V 50/60Hz 60s	
Static electricity	± 8000V	
Group pulse	± 2000V (5kHz/50kHz)	
Anti-vibration	10~50Hz, 0.5mm amplitude, 2 hours each in X, Y, Z directions	
Degree of protection	IP65	
Connection	φ 4 mm, 2 m 3 wire cable	
Material	PBT+glass fiber (housing); PMMA (lens)	
Accessories	screwdriver	
Model No.	NPN	ESB-V30N
	PNP	ESB-V30P
		ESB-C20N
		ESB-C20P

Dimensions

Unit: mm

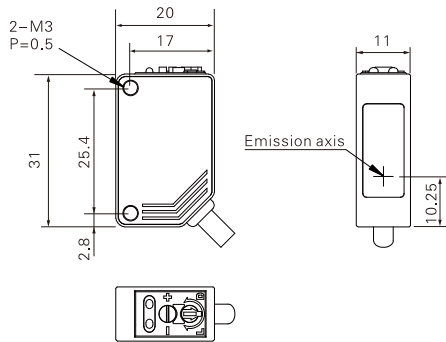

NPN Output

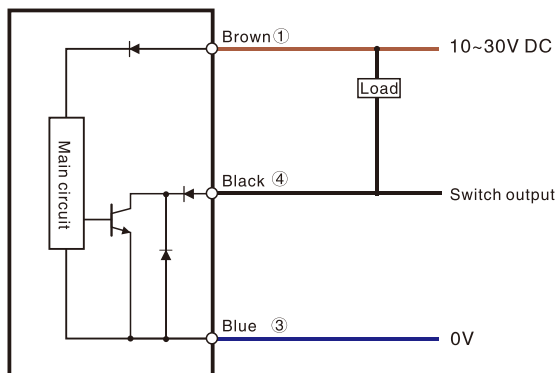

PNP Output

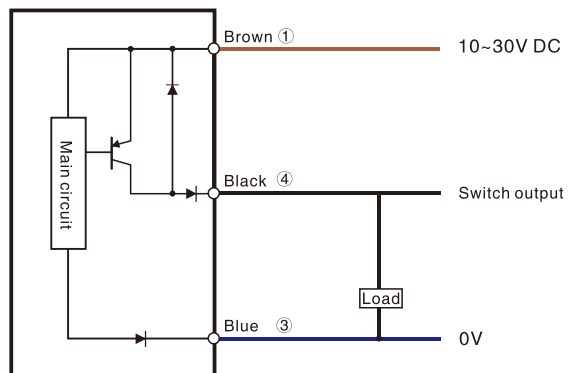

- Fiber Optic
- Slot Sensors
- Photoelectric**
- Laser
- Proximity
- Displacement
- Magnetic
- Contact
- Area
- Ultrasonic
- Vision
- Code Readers
- Vibration
- Temperature
- Accessories

Guidance

Photoelectric

- Cylindrical
- Square
- Flat type
- Thin type

BGS

- Transparent detection
- Color/Mark Detection
- TOF type
- IP69K high protection type
- Anti-glare type
- IO-Link type

Reflectors

- Reflectors

Transparent Detection

EST Series

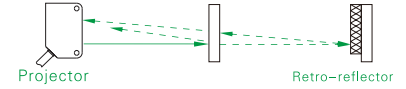

Appearance		
Sensing type	Retro-reflection	
Spot size	General Type	Coaxial beam
Sensing distance	0.01~2m	0~2m
Spot size	φ 300mm/200cm	φ 60mm/200cm
Output type	NPN/PNP Open-collector, ≤100mA/30V DC	
Switch type	Selectable L.on/D.on	
Indicator	Work indicator: Green; Output indicator: Orange	Output indicator: Orange
Response time	0.5 ms	
Light source	Red light LED(660nm)	
Operating voltage	10~30V DC ± 10%	
Current consumption	<20mA	
Load current	≤100mA	
Ambient illuminance	Sunlight≤10000Lux, Incandescent lamp≤3000Lux	
Ambient temperature	-25℃~+55℃, No freezing	
Ambient humidity	35%~85%RH, No condensation	
Degree of protection	IP67	
Connection method	2M 3 core cable	
Material	ABS with glass fiber (Housing); PMMA(Lens)	
Accessories	reflector	Bracket, reflector, mounting screw
Model No.	NPN EST-200N PNP EST-200P	EST-X200N (HOT) EST-X200P

Dimensions

Unit: mm

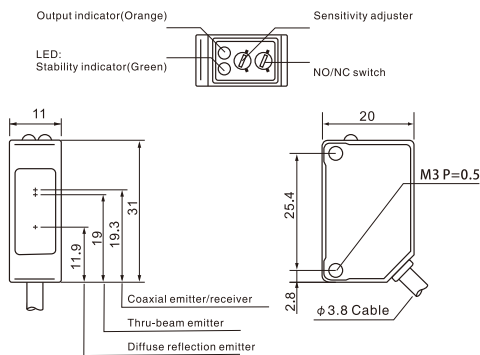

EST-200 Reflector:

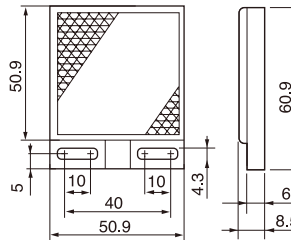

(Standard TD-11)

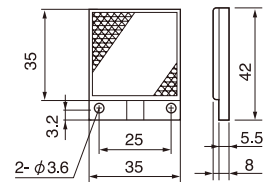

(Optional TD-12)

Noted:
Coaxial products only have one orange LED output indicator.

EST-X200 Reflector:

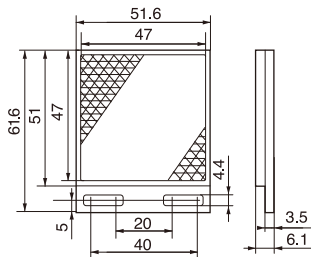

(Standard TD-13)

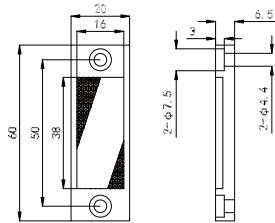

(Optional TD-14)

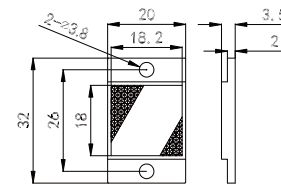

(Optional TD-15)

NPN Output

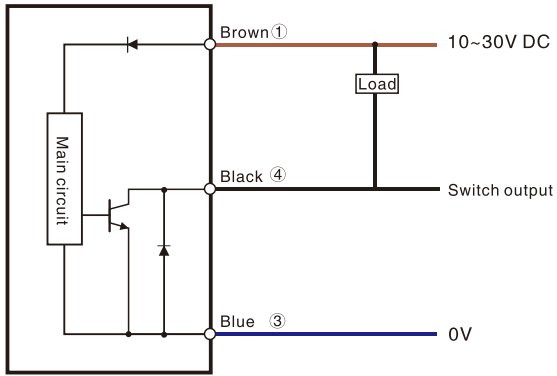

PNP Output

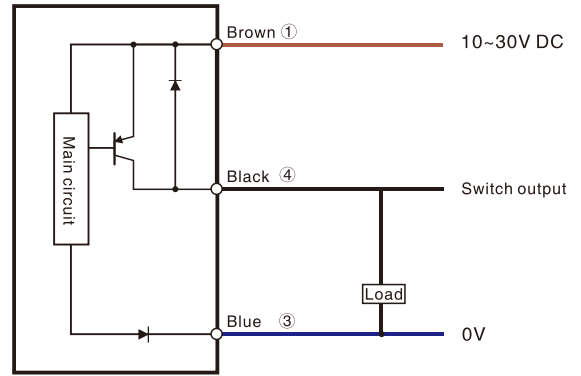

- Fiber Optic
- Slot Sensors
- Photoelectric**
- Laser
- Proximity
- Displacement
- Magnetic
- Contact
- Area
- Ultrasonic
- Vision
- Code Readers
- Vibration
- Temperature
- Accessories

Guidance

Photoelectric

- Cylindrical
- Square
- Flat type
- Thin type
- BGS
- Transparent detection**
- Color/Mark Detection
- TOF type
- IP69K high protection type
- Anti-glare type
- IO-Link type

Reflectors

- Reflectors

Color/Mark Detection

ESC Series



Appearance

Sensing type	Diffuse reflection
Sensing distance	18 ± 2mm
Spot size	φ 6mm/18mm
Output type	NPN/PNP Open-collector, ≤100mA/30V DC
Switch type	Selectable L.on/D.on
Indicator	Output indicator: Orange; Work indicator: Green
Digital display	7 segments, 3 digit display (Red and Green LED)
Response time	Mask mode: H1/0.25 ms, H2/0.5 ms, L/1.2 ms Color mode: H1/0.8 ms, H2/1.6 ms, L/4 ms
Time delay function	OFF delay/ ON delay/ Single pulse delay (0~990ms:10ms; 1~10s unit:1s)
Light source	RGB 3 color light source
Operating voltage	10~30V DC ± 10%
Current consumption	≤40mA
Load current	≤100mA
Ambient illuminance	Sunlight ≤10000Lux, Incandescent lamp ≤3000Lux
Ambient temperature	-25°C~+55°C, No freezing
Ambient humidity	35%~85%RH, No condensation
Insulation resistance	≥20 Ω (500V DC)
Impact resistance	50G(500m/s ²), XYZ three directions
Degree of protection	IP67
Connection method	2M 4 core cable
Material	Housing: ABS, Lens: PMMA
Accessories	Bracket, mounting screw
Model No.	NPN ESC-18N PNP ESC-18P

Dimensions

Unit: mm

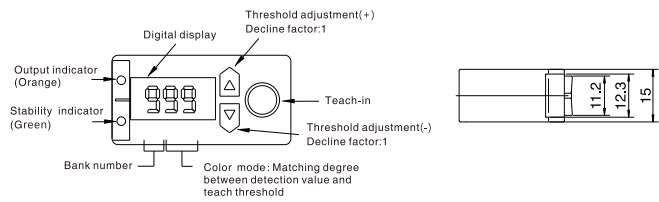
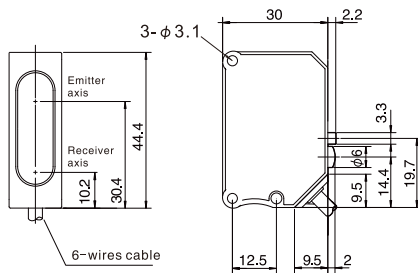

Circuit diagram

NPN Output

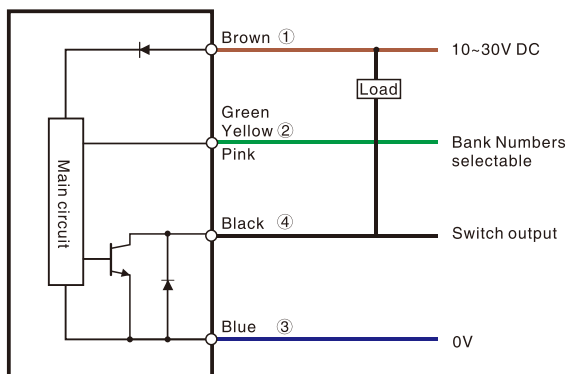

PNP Output

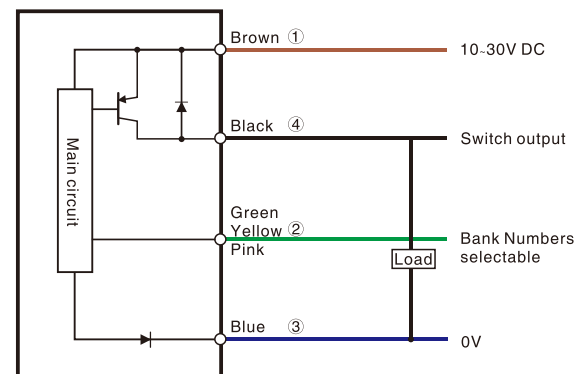



NEW!

Appearance	
Sensing type	Diffuse reflective
Sensing distance	20mm ± 3mm
Spot size	1x5mm (setting distance: 20mm)
Output	NPN / PNP for option
Switch type	L.on /D.on switchable
Indicators	Work indicator: Green, motion indicator: Red
Response time	Mark mode: 0.5ms; color mode: 2ms
Digital display	4 digits
Power supply	12~24V Dc ± 10%
Residual voltage	< 1.5 V (load current < 50 mA)
Current consumption	<35mA (24V)
Load current	< 50mA
Circuit protection	Reverse polarity protection / short circuit protection
Ambient temperature	-10~55°C, no freezing
Storage temperature	-20°C~70°C
Ambient humidity	35~85%RH, no condensation
Storage humidity	35~85%RH
Withstand voltage	± 1000V 50/60Hz 60s
Static electricity	± 8000V
Degree of protection	IP67
Group pulse	± 2000V
Anti-vibration	10~50Hz, amplitude 1.5 mm; 2 hours each in X, Y, Z directions
Ambient luminance	Incandescent lamp: ≤3,000 lux, Sunlight: ≤10000 lux
Model No.	NPN ESE-20N PNP ESE-20P

- Fiber Optic
- Slot Sensors
- Photoelectric**
- Laser
- Proximity
- Displacement
- Magnetic
- Contact
- Area
- Ultrasonic
- Vision
- Code Readers
- Vibration
- Temperature
- Accessories

Guidance

Photoelectric

- Cylindrical
- Square
- Flat type
- Thin type
- BGS
- Transparent detection
- Color/Mark Detection**
- TOF type
- IP59K high protection type
- Anti-glare type
- IO-Link type

Reflectors

- Reflectors

Dimensions

Unit: mm

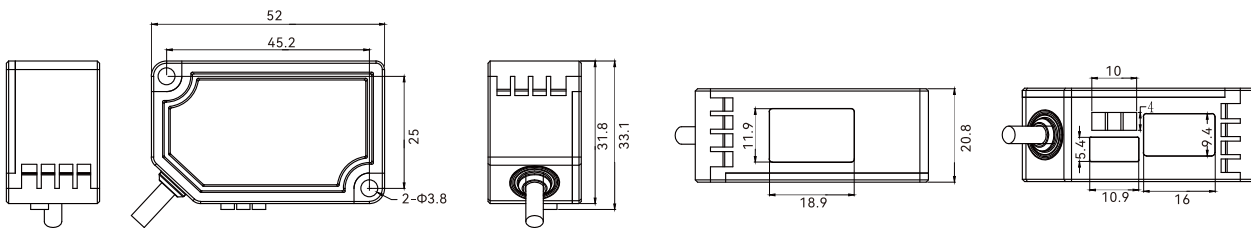

Circuit diagram

NPN Output

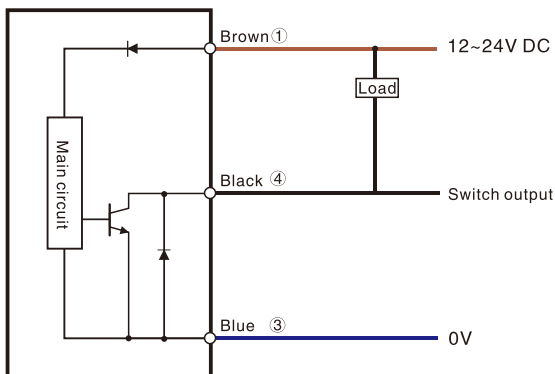

PNP Output

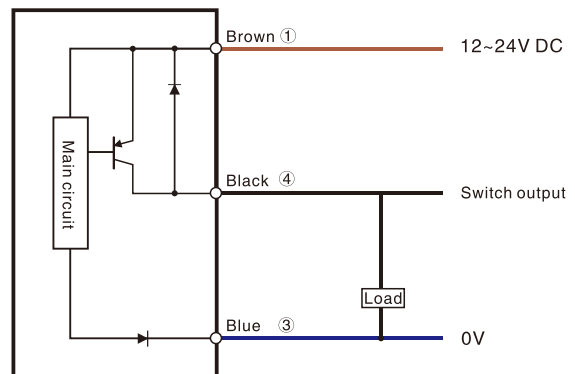

Reflectors

Dimensions

Unit:mm

STD-06

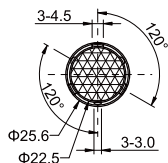

Thickness: 8mm

TD-04

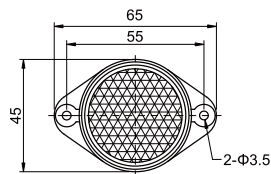

Thickness: 8mm

TD-05

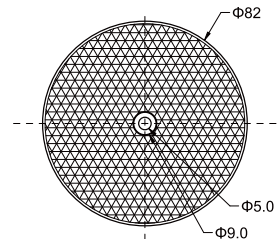

Thickness: 8mm

TD-09

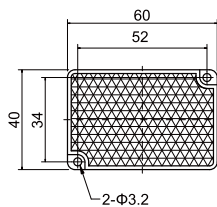

Thickness: 8mm

TD-02

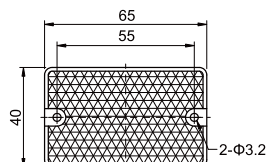

Thickness: 8mm

TD-08

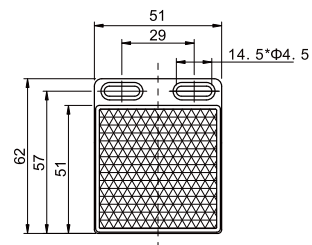

Thickness: 8mm

TD-01

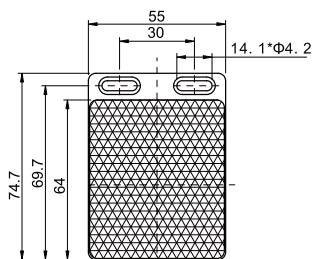

Thickness: 8mm

TD-03

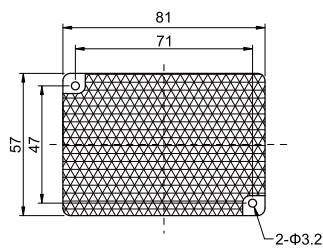

Thickness: 8mm

TD-01-3

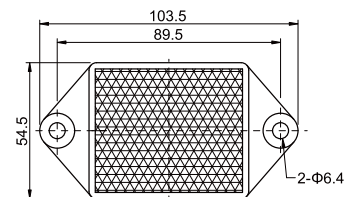

Thickness: 8mm

TD-10

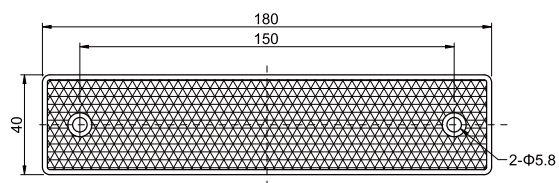

Thickness: 8mm

- Fiber Optic
- Slot Sensors
- Photoelectric
- Laser
- Proximity
- Displacement
- Magnetic
- Contact
- Area
- Ultrasonic
- Vision
- Code Readers
- Vibration
- Temperature
- Accessories

Guidance

Photoelectric

- Cylindrical
- Square
- Flat type
- Thin type
- BGS
- Transparent detection
- Color/Mark Detection
- TOF type
- IP69K high protection type
- Anti-glare type
- IO-Link type

Reflectors

Reflectors

TD-11

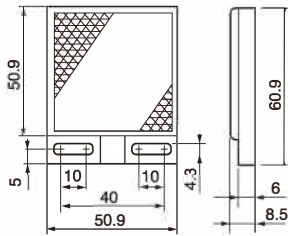

TD-12

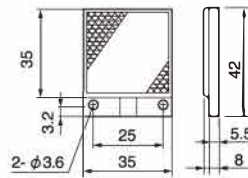

TD-13

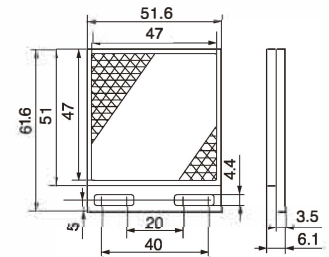

TD-14

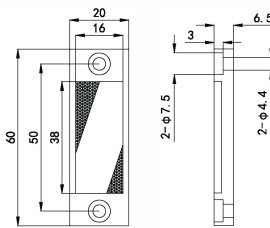

TD-15

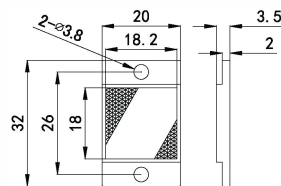

TD-22

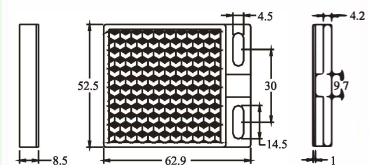

- Fiber Optic
- Slot Sensors
- Photoelectric**
- Laser
- Proximity
- Displacement
- Magnetic
- Contact
- Area
- Ultrasonic
- Vision
- Code Readers
- Vibration
- Temperature
- Accessories

Guidance

Photoelectric

Cylindrical

Square

Flat type

Thin type

BGS

Transparent detection

Color/Mark Detection

TOF type

IP69K high protection type

Anti-glare type

IO-Link type

Reflectors

Reflectors

ООО "РусАвтоматизация"

454010 г. Челябинск, ул. Гагарина 5, оф. 507

тел. 8-800-775-09-57 (звонок бесплатный), +7(351)799-54-26, тел./факс +7(351)211-64-57

info@rusautomation.ru; rusavtomatizatsiya.pf; www.rusautomation.ru