

# QA115HLS series

LED Strobe Warning Lights for Heavy-Duty Equipment

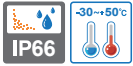

QA115HLS-Ø115mm  
QA115HLSP-Ø115mm

Adopted Qlight's new developed light diffusion system.



QA115HLS



QA115HLSP



## Common Specifications(QA115HLS/ QA125HLS)

LED Strobe warning lights for heavy-duty equipment applications, featuring superior luminous efficiency with Qlight's exclusive light diffusion system

- Ability to compensate for signal attenuation phenomenon that occurs during daytime operation with a powerful xenon lamp.
- Can select between pole mount and direct mount type to fit your application needs
- Materials : Lens-PC, Housing-PC
- Ambient operation temperature : -30°C to +50°C
- Protection rating : IP66
- Vibration resistant and shock-proof : Can withstand 15g of vibration and 100g of shock



## QA115HLS/ QA115HLSP LED Strobe Warning Lights

- Pole mount type model consists of a shock-proof rubber body; this feature provides excellent durability to vibration and shock
- Flashing rate : 45-55 flashes/min

Model number	Voltage	Current	Certificates	Weight	Color
QA115HLS	DC12V-24V	Max 0.730A	CE DC Only E11	1.06kg	● R-Red ● A-Amber
QA115HLSP				1.22kg	

※ DC type model has a free-voltage range of 10V-30V.



## Technical Diagram

(Units : mm)

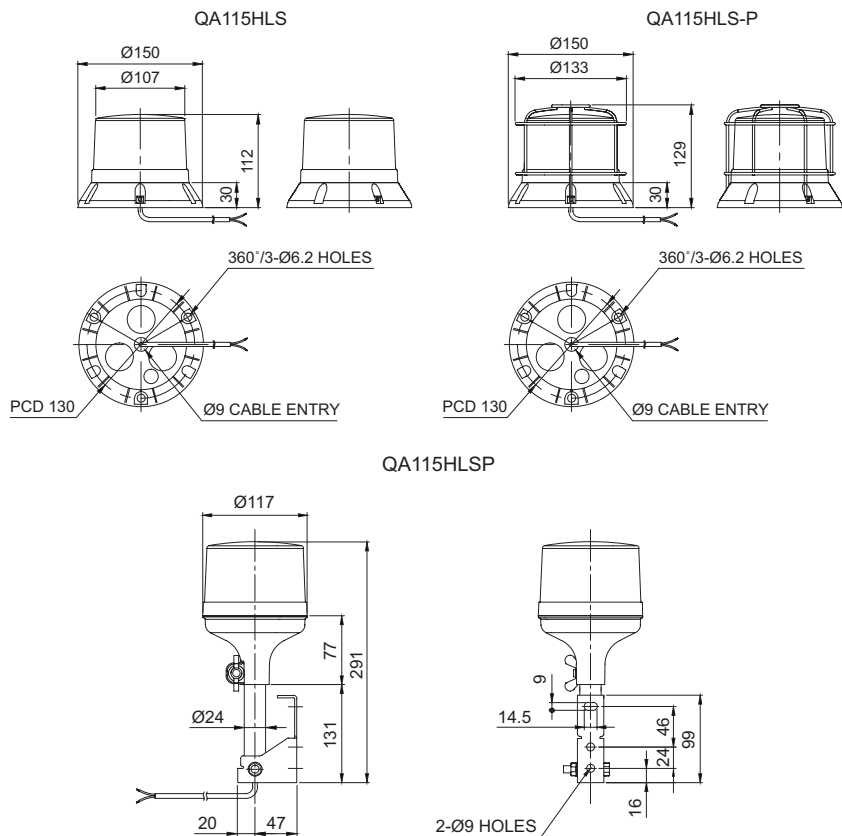

## Ordering Specification

QA115HLSP	-	12/24	-	R
[Model number]		[Voltage]		[Color]
• QA115HLS		• 12/24		• R-Red
• QA115HLSP		-DC12V-24V		• A-Amber



## Wiring Instructions

- External power line standard : UL2464 18AWG×2C 400mm
- Product can be wired regardless of polarity



## Customization

- User selected connector type available upon request
- Built-in protection cage (QA115HLS-P)