

INSTRUCTION MANUAL

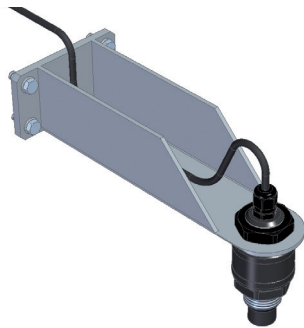

ULTRASONIC LEVEL METER ULM – 54



CONTENTS

1. Basic description	4
2. Range of application	4
3. Variants of sensors	5
4. Dimensional drawings	5
5. Installation and putting into operation	6
6. Mechanical mounting	6
7. Electrical connection	11
8. Connection examples ULM-54	12
8.1. Connection diagram of ULM-54 with UHC-01 converter	12
8.2. Connection diagram of ULM-54 with the PCU	15
8.3. Connection diagram of ULM-54 to the PDU	16
8.4. Connection diagram of ULM-54 to the MGU	16
9. Setting	15
9.1. Parametrization of connected level meter ULM-54 using PCU-100-H with the HART® protocol	17
9.2. Parameterization of ULM-54 using HART® protocol with UHC-01 communicator	24
10. Function and status indication	25
11. Order code	26
12. Accessories	27
13. Safety, protection and compatibility	27
14. Use, operation and maintenance	28
15. Marking of labels	28
16. Technical specifications	29
17. Packing, shipping and storage	30

USED SYMBOLS

To ensure maximum safety of control processes, we have defined the following safety instructions and information. Each instruction is labelled with the appropriate pictogram.



Alert, warning, danger

This symbol informs you about particularly important instructions for installation and operation of equipment or dangerous situations that may occur during the installation and operation. Not observing these instructions may cause disturbance, damage or destruction of equipment or may cause injury.



Information

This symbol indicates particularly important characteristics of the device.



Note

This symbol indicates helpful additional information.

SAFETY



All operations described in this instruction manual have to be carried out by trained personnel or by an accredited person only. Warranty and post warranty service must be exclusively carried out by the manufacturer.

Improper use, installation or set-up of the sensor can lead to crashes in the application.

The manufacturer is not responsible for improper use, loss of work caused by either direct or indirect damage, and for expenses incurred at the time of installation or during the period of use of the level sensors.

1. BASIC DESCRIPTION

The **ULM-54 ultrasonic level meters** are compact measurement devices including an electroacoustics converter, central processor unit and display module. Using the electro acoustics converter, the level meters transmit the sequence of ultrasonic pulses that propagate towards the level. The converter receives reflected acoustic waves that are subsequently processed in the electronic module. The intelligent evaluation block filters out interfering signals, compares the cleaned received signal with the false reflection map (e.g. from mixers, ladders, reinforcement etc.) and selects a suitable reflection (echo). Based on the period during which the individual pulses propagate towards the level and back and based on the measured temperature in the tank, the instant distance to the level is calculated. According to the level height, the level meter output is set: current 4 -20 mA with HART® protocol.

2. RANGE OF APPLICATION

The level meters are suited to level measurement of various liquid materials, sewerage waters, mash and paste materials, suspensions in closed or open vessels, sumps, reservoirs and open channels. In case the level of bulk solids is measured, the measurement range is reduced. We recommend to consult the use with the manufacturer.

Impossible use for strongly evaporating media, organic solventy or powders.

3. VARIANTS OF SENSORS

VARIANTS		
code	measuring range	description
ULM-54N-02	od 0,15 m do 2 m	all-plastic performance, PVDF emitter, process connection via G 1" screwing (upper or lower threads)
ULM-54N-06	od 0,25 m do 6 m	all-plastic performance, PVDF emitter, process connection via lower G 1½" or upper G 1" screwing
ULM-54N-10	od 0,4 m do 10 m	all-plastic performance, PVDF emitter, process connection via lower G 2¼" or upper G 1" screwing. Plastic flange connection can also be selected from the accessories menu.

4. DIMENSIONAL DRAWINGS

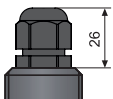
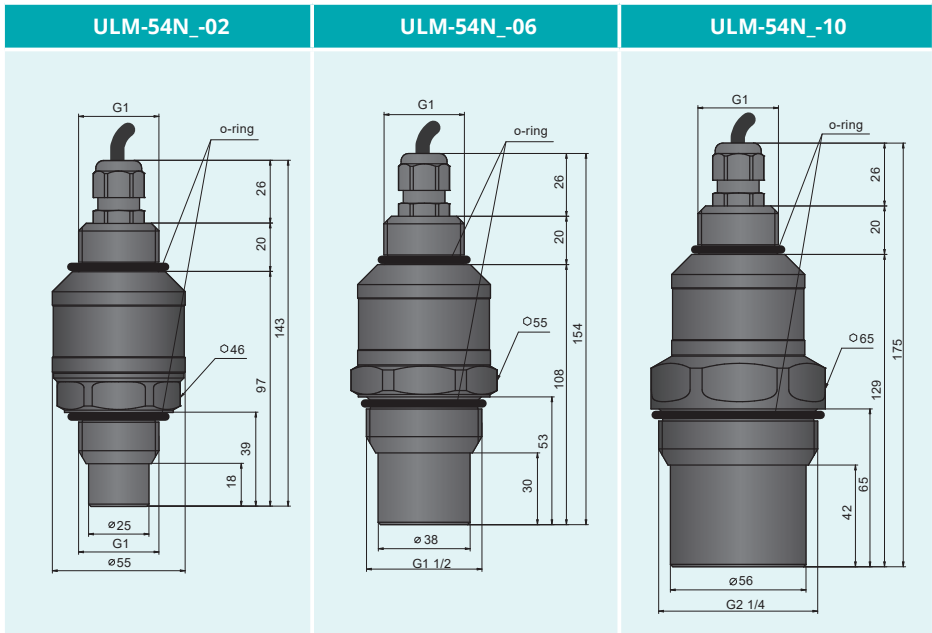

Variant "B" with short cable terminal PG11

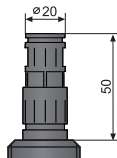

Variant "H" with outlet for protective conductor

5. INSTALLATION AND PUTTING INTO OPERATION

Please follow next 4 steps:

- **Mechanical mounting** - see chapter 6
- **Electrical connection** - see chapter 7
- **Settings** - see chapter 9

6. MECHANICAL MOUNTING

- The level meter is installed in a **vertical position** on the console or into the upper lid of the tank or reservoir using a lug, a fastening nut or a flange in such a way that the axis of the device is perpendicular to the level of the measured liquid (Fig. 1b). The level meter shall be installed in places with no risk of mechanical damage to the front of the sensor.

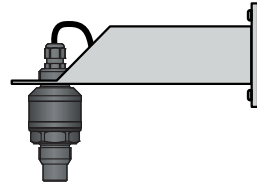

Fig. 1a: Recommended installation level meter ULM-54 on the console

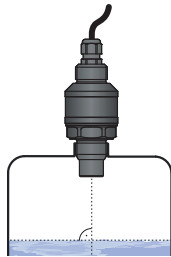

Fig. 1b: Recommended installation of the ULM-54 level meter in the tank using the bottom thread

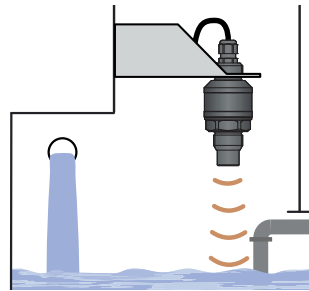

Fig. 1c: Recommended installation of the ULM-54 level meter in the tank via the upper thread

- The **minimum distance** when you are installing level meter into the lid or the ceiling of the tank are listed in Fig. 2.

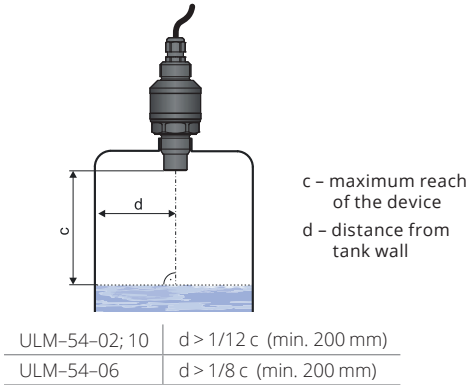

Fig. 2: Distance of the device from the tank wall

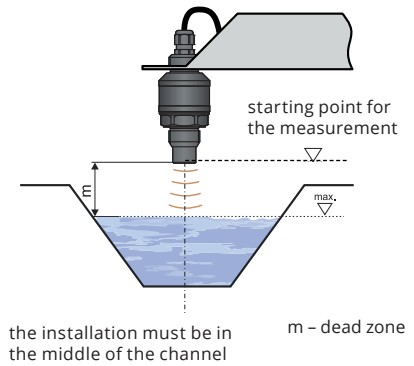

Fig. 3: Dead zone of the device

- When mounting in drains, the perpendicularity of the level meter axis to the measured level must be strictly observed and it is also recommended to install the level meter in the center of the drain so that the level meter is as far away from both edges of the drain as possible. Furthermore, it is necessary to choose the installation location so that at the maximum possible level, this level does not interfere with the dead zone of the level meter. If the situation allows, it is recommended to install the level meter in a quiet part of the drain, where the level does not clear.

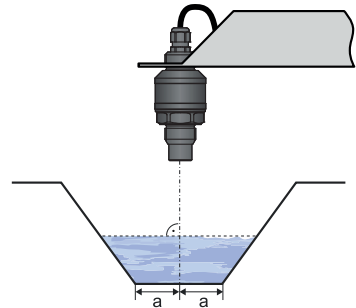
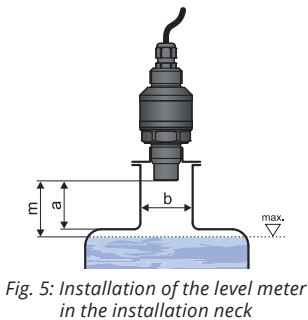

Fig. 4: Installation in the channel

- Only if the maximum level in the tank gets into the dead zone, the device shall be mounted into a higher **installation neck**. The tank can be then filled nearly up to the maximum volume. The neck's inner level shall be even and smooth (without edges and welded joints), the inner edge should be rounded in the spot where the ultrasonic wave leaves the pipe. Choose the largest possible neck diameter, but keep the neck height as low as possible. The recommended dimensions of the inlet neck are listed in Fig. 5.



ULM-70-02; 06	$a < 3 b$ $b > 100 \text{ mm}$
ULM-70-10	$a < 1,5 b$ $b > 100 \text{ mm}$

a – neck height from source edge
b – neck width
m – dead zone

- If the emitted acoustic signal of the level meter is affected by nearby objects (edges of drains and channels, unevenness on the tank walls, various partitions, stirrers, etc.), it is necessary to create a map of false reflections by activating the "**LEARNING**" mode. In the case of installed stirrers, it is necessary to move the stirrers to the position below the level meter (direct the stirrer blade to the place of the ultrasonic signal), see Fig. 6 and 7.

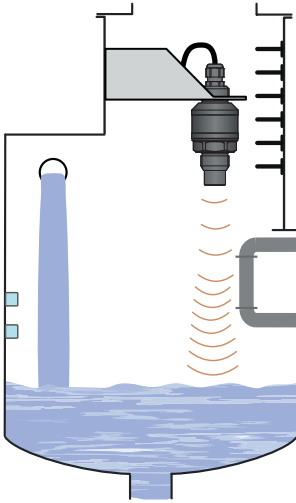

Fig. 6: False reflection from barrier

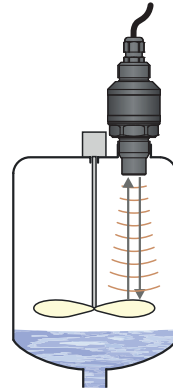
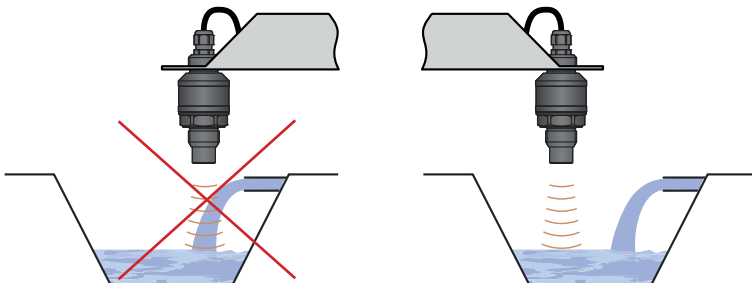

Fig. 7: False reflection from mixer blades

- Do not install the device in or above the filling point (Fig. 8). The measurement could be affected by the inflowing medium.



Obr. 8: Installation of the device out of reach of filling circulation

- **Foam** may be produced on the level of the measured liquid during filling, mixing and other processes. The thick foam significantly absorbs the ultrasound signal and may cause malfunction of the device (Fig. 9). In those cases it is necessary to set "SENSITIVITY" to the value "HIGH" and test the level meter in advance, or contact the manufacturer. In case of a thin layer of foam, it is also possible to use directional horn for improving receipt of the reflected echo.

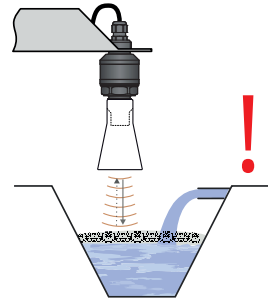

Fig. 9: Thick foam on the level

- In case the level of **bulk solids** is measured, the measurement range is reduced due to absorption of acoustic waves by a bulk medium, shortening of the measuring range occurs by up to 50% depending on the grain size. We therefore recommend selecting a level meter with greater range than the maximum range of measuring the medium. It is also appropriate to use a directional horn (see image 8), which reduces the shortening of the measuring range, because it better concentrates acoustic energy while preserving the same beam angle, and improves the sensitivity when receiving the reflected echo. We recommend to consult the use with the manufacturer.

- The ultrasonic signal can be scattered or attenuated if the level is **moderately stirred or rippled** (due to a mixer, inflow of liquid, etc.). This may result in reduction of the measurement range or unreliable operation of the device (Fig. 10).
- False level reflections of the ultrasonic signal and unreliable operation of the device might result from the mixer's **rotating blades** that ripple the level (Fig. 10). **For a rippled or swirling level, you can use the directional horn to eliminate scattering of the ultrasonic signal.**

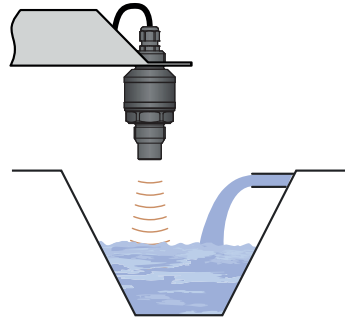

Fig. 10: wavy level

- If the level sensor is mounted to bottlenecks and places with barriers, or near uneven walls or the filling area, where the transmission signal could be distorted, we recommend using a guide tube (acoustic horn). The tube must be made from a single material with a smooth inner surface (see image 12a, 12b). The minimum tube diameter must have the dimension "b" according to image 4 on page 5. After installing, you must perform the procedure "LEARNING". **We recommend consulting with the manufacture on the construction of the guide tube.**

ULM-54-02	$h \geq 70 \text{ mm}$
ULM-54-06	$h \geq 100 \text{ mm}$
ULM-54-10	$h \geq 150 \text{ mm}$

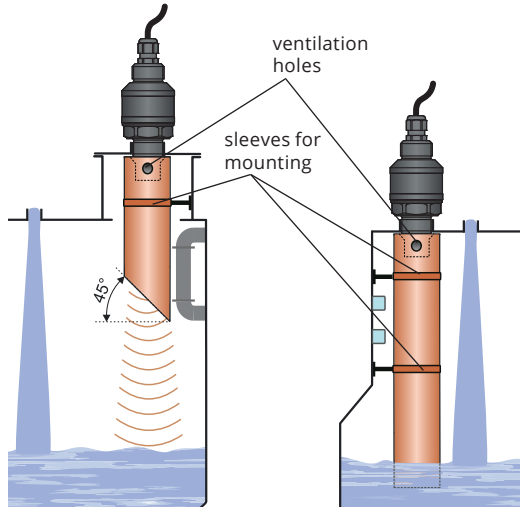

Fig. 11a: Short guide tube installation

Fig. 11b: Total guide tube installation

- The measuring device shall not be installed in **places with direct sunlight** and shall be protected against weather conditions. If installation in places with direct sunlight is inevitable, it is necessary to mount a shielding cover above the device (Fig. 12).
- It is advisable to keep cable under the **cable gland** (sagging down) as shown in Fig. 13 to prevent penetration of moisture. Rain and condensing water can be therefore drained away freely.
- The cable gland as well as the connector shall be **tightened sufficiently** to prevent penetration of moisture.

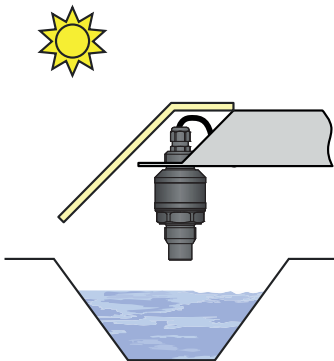

Fig. 12: Shielding cover against direct sunlight

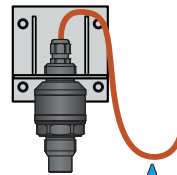
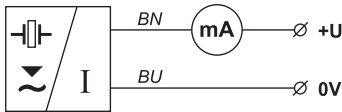

Fig. 13: Protection against penetration of moisture

7. ELECTRICAL CONNECTION

ULM-54 level meters with cable gland type B or H are equipped by 5m PVC cable (standard) for connection to evaluation (display) units by PVC cable 5 m long. Standard glands M16 x 1.5 (B) or protection glands (H). The connection diagram is shown in the figure.



Connection diagram

The positive supply pole +U is connected to the brown wire, the negative pole is connected to the blue wire.

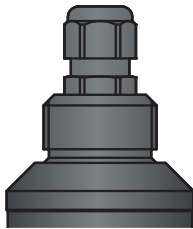

Performance „B“ with short cable gland

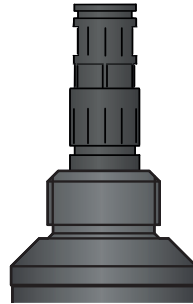

Performance „H“ with cable gland for protective hose



Wiring operations shall only be carried out without voltage!

The supply source should be preferably designed as a stabilized source of safe voltage with galvanic separation. If a switching power supply is used, its design must effectively suppress common mode interference. If the switching power supply is equipped with a PE protective terminal, it must be earthed!

If the sensor is located outdoors at a distance of more than 20 m from an outdoor switchboard or from an enclosed building, the electrical supply to the sensor must be supplemented with suitable over voltage protection.

In case of strong ambient electromagnetic interference, concurrence of the supply cable with the power line, or its length greater than 30 m, we recommend grounding the level meter (see above) and using a shielded cable. Ground the cable shield on the side of the power supply.

8. CONNECTION EXAMPLES ULM-54

A) Examples of connection to devices with current input 4 - 20 mA with the possibility of parameterization of ultrasonic level meter ULM-54 via HART communication protocol

8.1. CONNECTION DIAGRAM OF ULM-54 WITH UHC-01 CONVERTER

Parameterization is performed using UniScada Dinel software, which must be installed on the PC. The connection of the UHC-01 converter to a PC is typically made with a standard USB-A <-> USB-B cable.

The following sections show all possible connection variants. All figures show the output side of the converter towards the level meter, including communication LEDs and a switch for switching the communication HART resistor on or off.

Connection of ULM-54 powered by an internal source when using an internal communication HART resistor 250 Ω

This connection is used in case of connection of one level meter where no power supply is available or is not required and at the same time there is no communication HART resistor in the current loop. The switch is set to the ON position (highlighted in green).

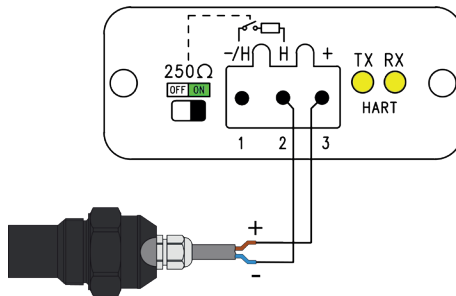

Obr. 14: Connection of a level meter which is powered by an internal source when using an internal communication HART resistor 250 Ω

Connection of ULM-54 powered by an internal source when using an external communication HART resistor 250 Ω

This connection is used in the case of connecting one level meter where no power supply is available or is not required and at the same time there is a communication HART resistor in the current loop. The switch is set to OFF (highlighted in green).

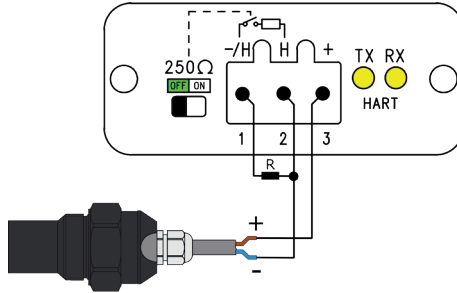

Obr. 15: Connection of a level meter which is powered by an internal source when using an external communication HART resistor 250 Ω

Connection of ULM-54 powered by an external source when using an internal communication HART resistor 250 Ω

This connection is used in the case of connecting one level meter where the use of an external power supply is required and at the same time there is no communication HART resistor in the current loop. The switch is set to the ON position (highlighted in green). The external power supply is marked as U in the connection.

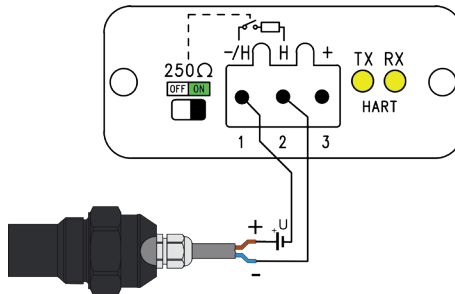

Obr. 16: Connection of a level meter which is powered by an external source when using an internal communication HART resistor 250 Ω

Connection of ULM-54 by the internal source when using the internal communication HART resistor 250Ω

This connection is used in the case of connecting one level meter where a power supply is not available or is not required and at the same time there is no communication HART resistor in the current loop. The switch is set to the ON position (highlighted in green).

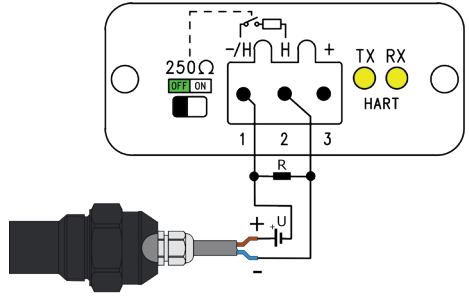

Obr. 17: Connecting a level meter powered by an internal source when using an internal communication HART resistor 250Ω

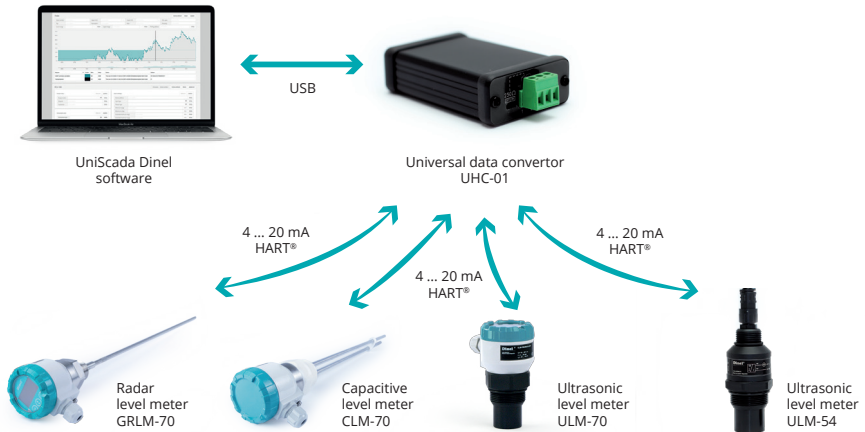

Obr. 18: UHC-01 converter connection options

8.2. CONNECTION DIAGRAM OF ULM-54 WITH THE PCU

Parameterization is performed directly from the PCU menu (see chapter 9 Level meter settings) or using the UniScada Dinel software, which must be installed on the PC. The PCU is connected to the PC with a standard USB-A <-> USB-B cable.

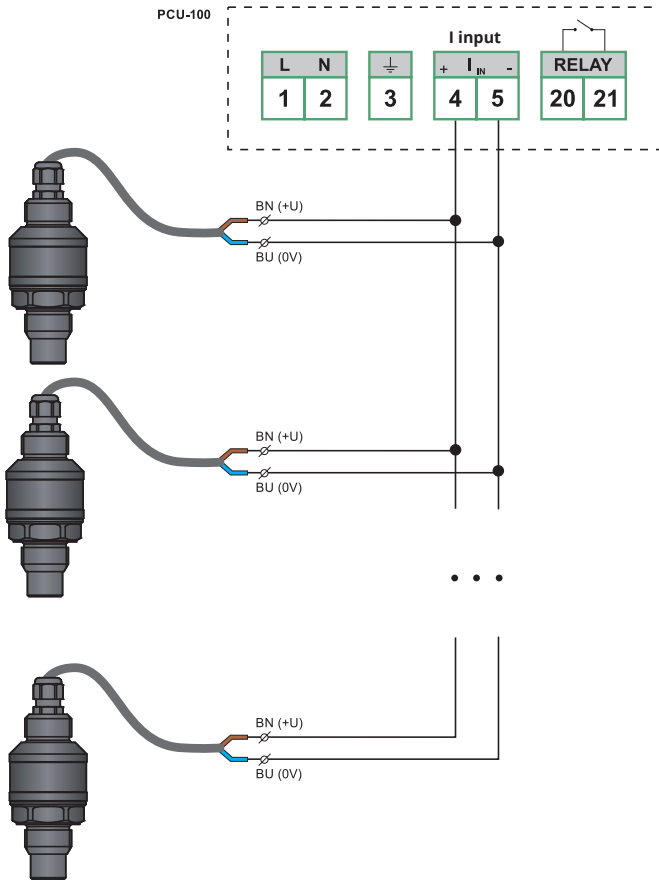

Obr. 19: Connecting multiple level meters to the PCU-100

B) Examples of connection to devices with current input 4 - 20 mA without the possibility of parameterization of ultrasonic level meter ULM-54

8.3. CONNECTION DIAGRAM OF ULM-54 TO THE PDU

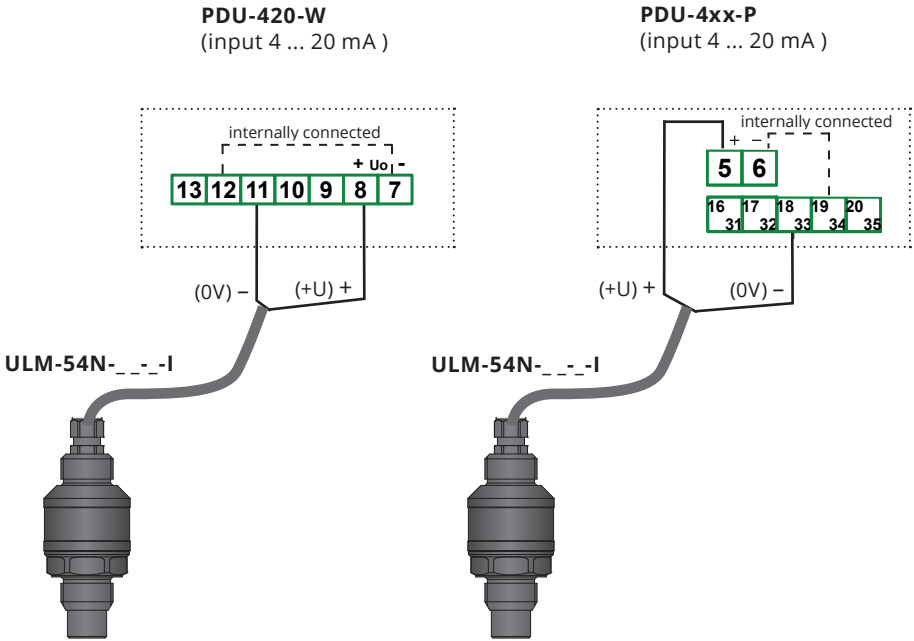

The PDU-420-W connection is valid for firmware version 6.00 or higher. For older versions (up to version 5.99), the level meter output + U is connected to terminal 7 and the 0 V output to terminal 10.

8.4. CONNECTION DIAGRAM OF ULM-54 TO THE MGU

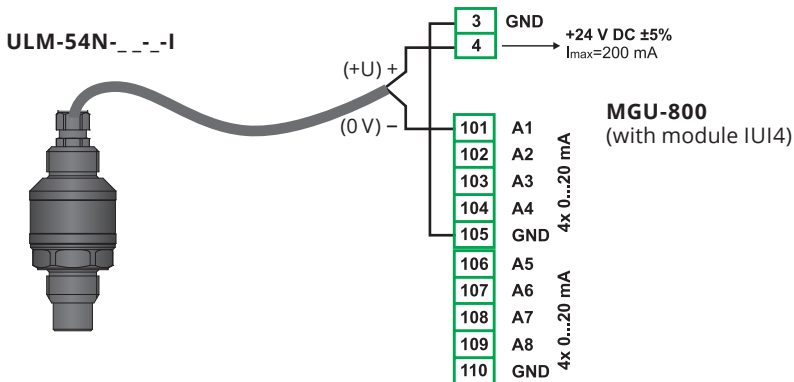

9. SETTING

9.1. Parametrization of connected level meter ULM-54 using PCU-100-H with the HART® protocol

The unit in PCU-100-H version makes it possible to communicate with measuring devices / level meters using the HART® protocol. HART® (Highway Addressable Remote Transducer) is a communication protocol used for setting up, reading measured data, and measuring device diagnostics. Communication proceeds via a 4–20 mA current loop and no additional wires are required. The unit allows communication via the HART® protocol with ULM-54, ULM-70, GRLM-70, and CLM-70 level meters from Dinel s.r.o. It also allows you to communicate with third-party measuring devices that comply with the HART® Protocol Revision 5 to 7 as defined in the protocol standard.

The menu for communication with the measuring probe using the HART® protocol is accessible only after successful connection to this device.

If the display shows 'DEVICE SEARCH', periodic attempts are made to establish communication with the measuring device.

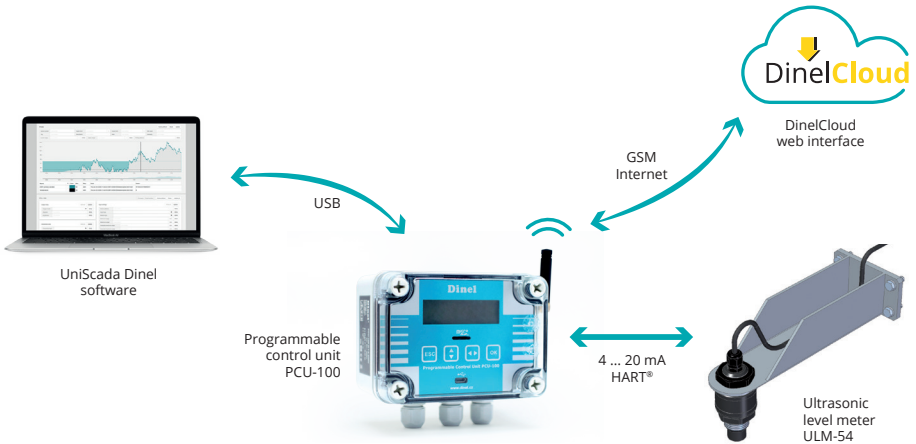

Fig. 16: PCU-100 connection diagram

9.1.1. Parametrization of Dinel level meters with the HART® protocol support

This part of the menu is intended only for setting the ULM-54, ULM-70, GRLM-70, and CLM-70 level meters from Dinel, s.r.o. It is not displayed when a different device is connected. The basic settings for these probes can also be carried out in the BASIC PARAMETRIZATION. In the mentioned menu, however, it is possible to set, in addition to the basic parameters, also some other parameters that are specific for the mentioned devices.

Lower range setting of the measured magnitude in the level meter

The value of the measured magnitude at which the level meter output will be at the minimum (4 mA) is entered here.

For level meter ULM-54 using the reflex method the data is entered in millimeters and represents the distance of the level from the front of the ultrasonic transducer. The value is always a floating-point decimal number.

- **Menu: MIN LEVEL (ID 072)**
- **[↔] - Movement between characters, [↑] - Increase in the value of the marked digit (at marked decimal point, a shift by one order occurs)**

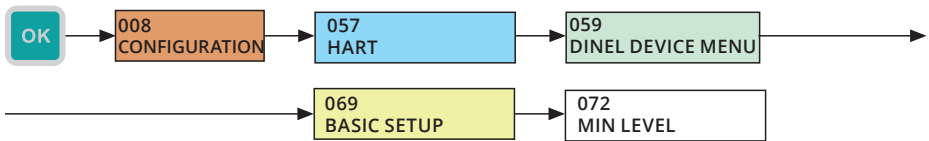

Upper range setting of the measured magnitude in the level meter

The value of the measured magnitude at which the level meter output will be at the maximum (20 mA) is entered here.

For level meter ULM-54 the value is entered in millimetres and it represents a distance of the level from the transducer face or from the beginning of the electrode. The value is always a floating comma number.

- **Menu: MAX LEVEL (ID 073)**
- **[↔] - Movement between characters, [↑] - Increase in the value of the marked digit (at marked decimal point, a shift by one order occurs)**

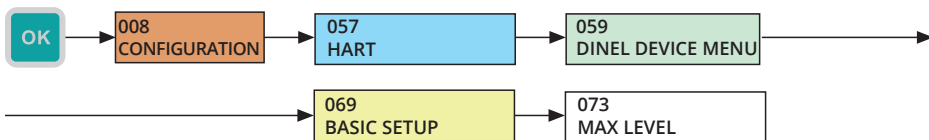

Physical units setting of the measured magnitude in the level meter

- mm – distance in millimetres
- cm – distance in centimetres
- m – distance in meters
- in – distance in inches
- ft – distance in feet
- pf - distance in picofarad

- **Menu: UNITS (ID 074)**

- **[↑] - Changing the unit**

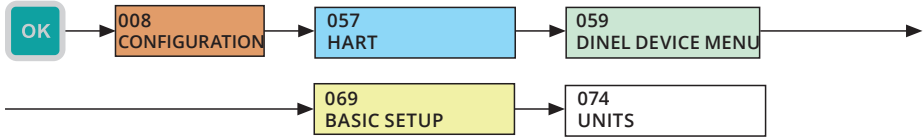

Averaging setting of the measured magnitude in the level meter

Setting of measurement response rate. It is useful to use the function for the suppression of fluctuations on the display at fast and jump changes in the level (whirling level). The subsequent reaction time will depend on the exponential curve. Damping with defined delay in seconds indicates the time that the exponential curve reaches 2/3 of its maximum value. The value is always a floating comma number.

- **Menu: DAMPING (ID 075)**

- **[↔] - Movement between characters, [↑] - Increase in the value of the marked digit (at marked decimal point, a shift by one order occurs)**

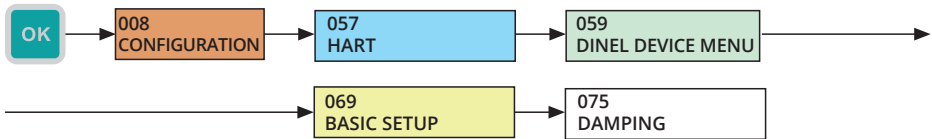

Reset of the level meter

This function restarts the measuring device. The option must be confirmed with "YES".

- **Menu: RESET (ID 083)**

- **[↔] - Change of the YES / NO option**

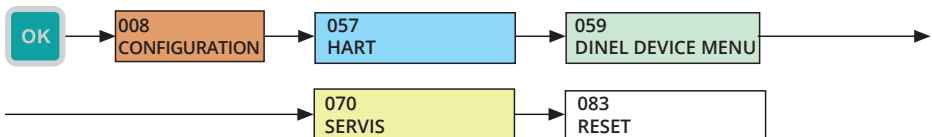

Sending a message to the level meter

The type and contents of supported messages depend on the connected device.

- Menu: **MESSAGE (ID 068)**
- [↔] - Movement between characters, [↑] - Character change

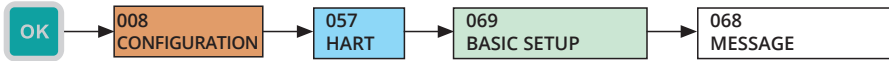

Sensitivity setting of the level meter

Preset sensor sensitivity levels are LOW (1), MEDIUM (3), and HIGH (5). To change the sensor sensitivity, select the appropriate item and confirm it.

The setting defines the sensitivity of the ULM-54 level meters in three steps:

- "LOW" - reduced sensitivity in case of ambient interference affecting the measurement.
 - "MEDIUM" - medium sensitivity (suitable for most applications)
 - "HIGH" - increased sensitivity for media partially absorbing the ultrasonic signal (bulk materials, foam).
- Menu: **SENSITIVITY (ID 076)**
 - [↑] - Sensitivity change

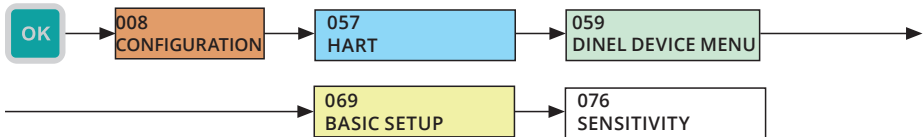

Start teaching in the level meter

A more detailed description is given in the instruction manual for each level meter. The indication of teaching that is running is shown in the DEVICE INFO menu in the STATUS line, where the TEACHING RUNNING text is displayed. After teaching is complete, the text changes to TEACHING ACTIVE.

The mode is used to suppress **false reflections** caused by the reflection of the ultrasonic signal from unevenness on the tank walls, various partitions, stirrers or other obstacles. After starting this mode, the sensor detects false reflections and stores them in memory. After that, these false reflections will not affect the subsequent measurement (they are masked).

Before starting the mode, it is necessary to drain the tank as much as possible (preferably completely).

In the case of installed stirrers, it is necessary to move the stirrers to a position below the level meter (direct the stirrer blade into the ultrasonic signal beam).

Note: If significant obstacles occur in the upper half of the tank, multiple false reflections may occur, especially in closed tanks. In such cases, it is necessary to drain the level in the tank as low as possible so that these possible multiple false reflections are properly masked.

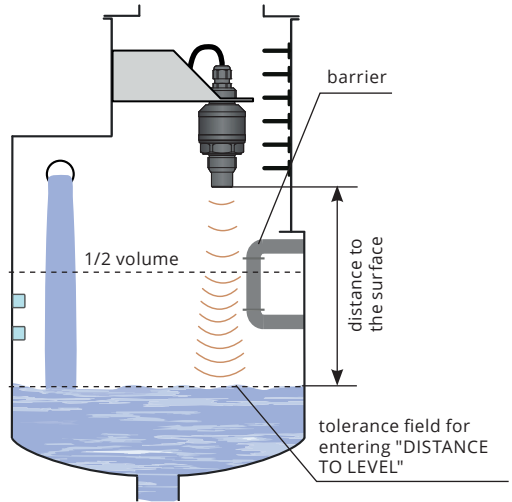

Obr. 17: Water level for entering a value „Set level distance“

- Menu: **TEACHING (ID 078)**
- [↔] - Change of the YES / NO option

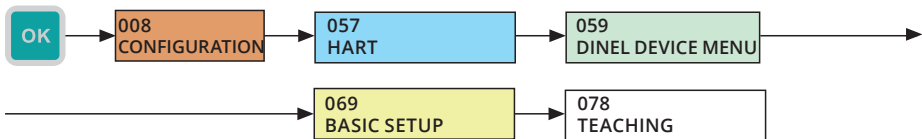

Setting of the medium temperature in the level meter

In this part of the menu, the medium temperature is set.

MEDIA TEMPERATURE

The level meter contains **automatic temperature compensation**. For example, if there is a 10 ° C **difference** in the tank between the temperature of the measured substance (medium) and the temperature at the installation site of the level meter (see "DIAGNOSTICS" mode p. 22), the measurement accuracy is reduced by approx. 1% of the set range. If this function is activated, this temperature difference can be compensated.

When starting the **zone temperature compensation** mode, it is necessary to enter the temperature at the level of the measured medium. The level meter then calculates the average value from the medium temperature and the temperature at the installation site of the level meter. This average temperature is taken into account when determining the speed of propagation of acoustic waves and when determining the position of the level.

- Menu: **MEDIUM TEMPERATURE (ID 080)**
- [↔] - Movement between the characters; [↑↓] - Change of value

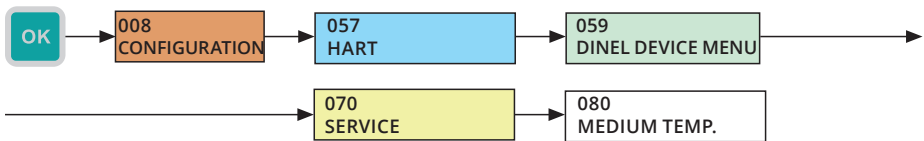

Factory default of the level meter

It allows you to delete all user-set changes and return the level meter to the factory default settings.

- Menu: **FACTORY DEFAULT (ID 082)**
- [↔] - Change of the YES / NO option

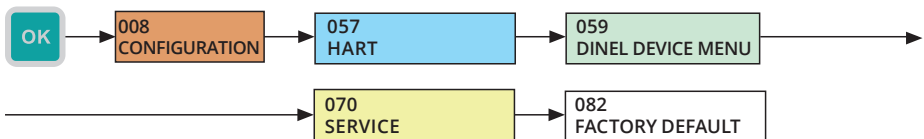

- **POLLING ADDRESS**
The numerical address of the device in the range of 0–15, serving for identification and recognition of individual level meters connected to the PCU.
- **TAG**
Device text identifier.
- **DESCRIPTION**
Additional text description of the connected device.
- **STATUS**
Information on the actual status of the connected device. It is displayed only in Dinel s.r.o. products. (ULM-54, ULM-70, GRLM-70, and CLM-70). It can acquire the following values:
 1. **ECHO OK:** The echo (reflection) was captured in the last measurement.
 2. **LEVEL_ABOVE_RANGE:** The measured level is above the measuring range or within the dead zone.
 3. **LEVEL_BELOW_RANGE:** The measured level is below the measuring range.
 4. **TEACHING_RUNNING:** TEACHING is running (an empty tank curve is created) or electrode is changed.
 5. **TEACHING_ACTIVE:** TEACHING: is active (a newly created empty tank curve is used).
 6. **LOW_VOLTAGE:** Low supply voltage.
- **CURRENT**
Current in loop in mA.
- **PV**
Primary measured value. For the ULM-54, ULM-70, and GRLM-70 level meters it is a distance to the level, for CLM-70 it is a capacity.
- **SV**
Secondary value. This value is shown on the display of the level meter.
- **TV**
Tertiary value. For the ULM-54 and ULM-70 probes it is the temperature in °C. Not used for the GRLM-70 and CLM-70 probes.
- **QV**
Quaternary value. For the GRLM-70, ULM-54 and ULM-70 level meters, it is a height of level. For the CLM-70 level meters, this value and the primary value are identical.
- **UPPER LIMIT**
The highest possible primary value that the level meters can measure.
- **LOWER LIMIT**
The lowest possible primary value that the level meters can measure.
- **END OF RANGE**
The actual maximum possible value of the primary quantity measured. It can be changed in the menu [link to menu 9.6.2] in the range given by the LOWER LIMIT and UPPER LIMIT values.

- **START OF RANGE**
The actual minimum possible value of the primary quantity measured. It can be changed in the menu [link to menu 9.6.2] in the range given by the LOWER LIMIT and UPPER LIMIT values.
- **DAMPING**
An averaging value that allows you to suppress unwanted fluctuations at fast and jump changes in the measured quantity. It can be changed in menu [link to menu 9.6.4]
- **SERIAL NUMBER**
Device serial number.

9.2. Parameterization of ULM-54 using Hart® protocol with UHC-01 communicator

To set up the level meter and collect the measured data, it is necessary to have a HART® communicator, which can be used to communicate directly with the level meter or use it to mediate communication with a peripheral device, see Fig. 18.

For this purpose, Dinel® offers the UHC-01 converter, which is designed for connection of all level meters supporting the HART® communication protocol over the current loop in order to configure them and read the measured values via the appropriate software on a PC. The supplied software from Dinel s.r.o can be used as software. or possibly another that can communicate via the HART® protocol via a virtual serial port.

The UHC-01 converter allows you to switch the communication HART® resistor (250 Ω) on or off using a mechanical switch.

In addition to the input and output for HART® communication, the UHC-01 transmitter also contains a power supply for measuring probes (24 V / 45 mA) with short-circuit protection.

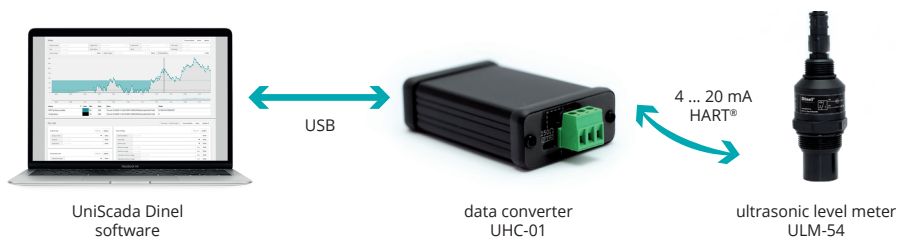

Obr. 18: Connection of peripheral devices via HART® protocol using UHC-01

HART specification for ULM-54 level meter

Revision

The implemented HART protocol is revision No. 5

Universal commands

0	Read unique identifier
1	Read primary variable
2	Read current and percent of range
3	Read current and four (predefined) dynamic variables
6	Write polling address
11	Read unique identifier associated with tag
12	Read message
13	Read tag, descriptor, date
14	Read PV sensor information
15	Read output information
16	Read final assembly number
17	Write message
18	Write tag, descriptor, date
19	Write final assembly number

Standard (practical) commands

34	Write damping value
35	Write range values
40	Enter/exit fixed current mode
42	Perform master reset
44	Write PV units
49	Write PV sensor serial number

10. FUNCTION AND STATUS INDICATION

Fault status signaling is performed by means of:

- fault currents, see table of default settings, page 27

11. ORDER CODE

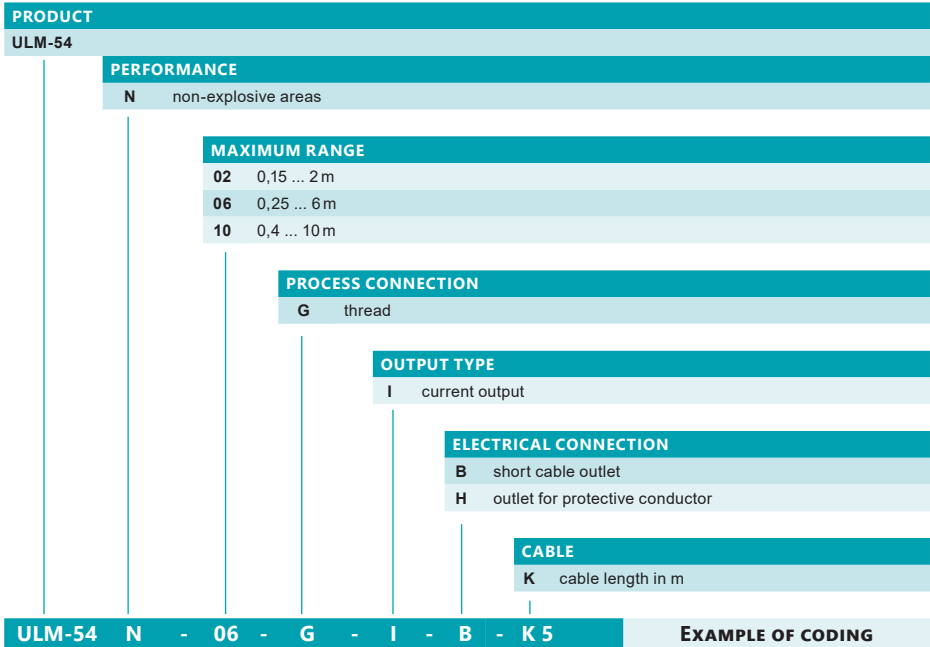

12. ACCESSORIES

ACCESSORIES			
2x seals (o-ring) (material: NBR)	included in the price		
Universal USB to HART® converter	at extra cost	UHC-01	
Horn adapter	at extra cost	ST-G 1 ST-G 1½ ST-G 2¼	
Plastic fixing nuts	at extra cost	PUM-G 1 PUM-G 1½ PUM-G 2¼	
Weld flanges stainless steel (NN) or carbon steel (ON)	at extra cost	NN-G1 ON-G1 NN-G1½ ON-G1½	
protecting hose (for H cable gland)	at extra cost		

13. SAFETY, PROTECTION AND COMPATIBILITY

Level meter ULM-54 is equipped with protection against electric shock on the electrode, reverse polarity, output current overload, short circuit and against current overload on output.

Protection against dangerous contact is provided by low safety voltage according to 33 2000-4-41.

Electromagnetic compatibility is provided by conformity with standards EN 55011/B, EN 61326-1 and EN 61000-4-2 to 6.



The device must be installed in such a way that mechanical damage to the sensor face cannot occur.

14. USE, OPERATION AND MAINTENANCE

The level meter does not require any operation for operation. During operation, the operator of the technological unit is informed about the level of the measured substance by means of a follow-up display device and a level meter display at the installation site.

The maintenance of the device consists in checking the integrity of the level meter and the supply cable. Depending on the nature of the measured substance, we recommend checking the cleanliness of the radiating level of the ultrasonic transducer at least once a year, or clean it. If any visible defects are found, the manufacturer or dealer of the device must be contacted immediately.



It is forbidden to make any changes or interventions on the ULM-54 level meter without the consent of the manufacturer. Any repairs must only be carried out by the manufacturer or a service organization authorized by him.

The assembly, installation, commissioning, operation and maintenance of the ULM-54 level meter must be carried out in accordance with these instructions and the provisions of the applicable standards for the installation of electrical equipment must be observed.

15. MARKING OF LABELS

Data on the plate of the unit of ULM-54N-__-I-__

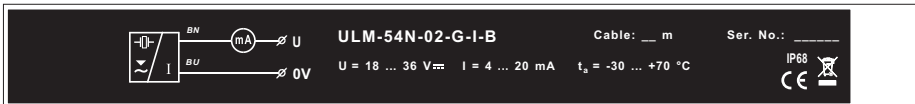

Example of a label for a device of type ULM-54N-02-G-I-B

Temperature range by type:	02	ta = -30 ... +70°C
	06	ta = -30 ... +70°C
	10	ta = -30 ... +60°C

Symbol of producer: logo Dinel®

Internet address: www.dinel.cz

Type of level meter: ULM-54N-__-I-__

Product serial number: Ser. No.: xxxxx - (from left: year of manufacture, serial production No.)

Supply voltage range: U = 18 ... 36 V =

Output current range: I = 4 ... 20 mA

Ambient temperature range: t_a = -30 ... +__ °C (Temperature range according to the type)

protection: IP68

mark of conformity: **CE**

mark for take-back of electrical waste:



The size of the labels is 175 x 20 mm, the size shown does not correspond to reality.

16. TECHNICAL SPECIFICATIONS

TECHNICAL SPECIFICATIONS – LEVEL METER		
Measuring range ¹⁾	ULM-54_-02 ULM-54_-06 ULM-54_-10	0,15 ... 2 m 0,25 ... 6 m 0,4 ... 10 m
Adjustable measuring range		min. 200 mm
Supply voltage	ULM-54N-__	18 ... 36 V DC
Output	ULM-54_-__-_-I	4...20 mA (Limit values 3,9...20,5 mA), HART®
Current consumption	ULM-54_-__-_-I	4 ... 20 mA / max. 22 mA
Resolution	ULM-54_-02; 10 ULM-54_-06	< 1 mm < 2 mm
Accuracy (within the total range)		0,15 %
Temperature error		max. 0,04 % / K
Operating frequency	ULM-54_-02 ULM-54_-06 ULM-54_-10	120 kHz 75 kHz 50 kHz
Beamwidth (-3 dB)	ULM-54_-02; 10 ULM-54_-06	10° 14°
Ambient temperature range	ULM-54_-02 ULM-54_-06 ULM-54_-10	-30 ... +70 °C -30 ... +70 °C -30 ... +60 °C
Short-time temperature stress resistance		+90 °C / 1 hour
Max. operation overpressure (on transmission level)		0,1 MPa
Sensitivity		3 steps (low – medium – high)
Damping		0 ... 99 s
Measuring period		1 ... 4 s
Rise time		cca. 30 s
Status signaling		echo loss 3,75 mA level in the dead zone ²⁾ 22 mA
Protection class		IP68
Mechanical connection	ULM-54_-02 ULM-54_-06 ULM-54_-10	screwing with thread G 1" (upper or lower threads) screwing with thread G 1½" and upper thread G 1" screwing with thread G 2¼" and upper thread G 1"
Cable	ULM-54_-__-_-I	PVC 2 x 0,75 mm ²
Maximal resistance of current output load (U = 24 V DC)	U = 24 V DC U = 22 V DC U = 20 V DC U = 19 V DC	R _{max} = 270 Ω ³⁾ R _{max} = 180 Ω R _{max} = 90 Ω R _{max} = 45 Ω
Weight	ULM-54_-02 ULM-54_-06 ULM-54_-10	0,2 kg 0,25 kg 0,65 kg

1) In case the level of bulk-solid materials is measured, the measurement range is reduced.

3) Dead zone = Blind zone = Blocking distance

4) Including 250Ω resistor in case of HART® connection.

USED MATERIALS

sensor part	variants	standard material
Housing with thread	All types	plastic PP
Electroacoustic converter	All types	plastic PVDF
Cable gland	All types	plastic PA

FACTORY DEFAULT

	ULM-54_-02	ULM-54_-06	ULM-54_-10
MIN LEVEL ¹⁾	2 000	6 000	10 000
MAX LEVEL ²⁾	150	250	400
UNITS	mm; %; °C	mm; %; °C	mm; %; °C
DAMPING	2	5	10
SENSITIVITY	MEDIUM	MEDIUM	MEDIUM
MEDIUM TEMPERATURE	NO	NO	NO
FAILURE MODE - NO ECHO	3,75 mA	3,75 mA	3,75 mA
FAILURE MODE - DEAD ZONE ³⁾	22 mA	22 mA	22 mA
POOLING ADDRESS (HART®)	00	00	00
PASSWORD	No password	No password	No password

¹⁾ Distance to min. level

²⁾ Distance to max. level

³⁾ Dead zone = Blind zone = Blocking distance

17. PACKING, SHIPPING AND STORAGE

The ULM-54 is wrapped in a polyethylene bag and the whole consignment is placed in a card box. In the carton box, appropriate padding is used to prevent mechanical damage during transport.

Remove the device from the packaging just before its use, you may avoid possible damage.

The transport to the customer is realized by means of a forwarding company. After a prior agreement, personal taking of the ordered goods from headquarters is also possible. When taking over, please make sure that the consignment is complete and corresponds to the extent of the order, and that no damage occurred to the device when transporting. Do not use a device obviously damaged during transport, but contact the manufacturer in order to address the situation.

If the device is to be transported further, then only wrapped in the original packaging and protected against shocks and weather conditions.

Store the device in the original packaging in dry areas covered from the weather conditions, with a moisture up to 85 % without any effects of Chemically active substances. Storage temperature range is -20 °C to +60 °C.



Level meters (sensors) of type variants ULM -54_ - 02, 06, 10 are equipped with protective covers to prevent damage to the ultrasonic sensor. Remove the cover before commissioning!