

Multi -channel modular temperature controller

TM Series

User Manual



TM Series



Preface

Thank you for purchasing an Autonics product.

Please familiarize yourself with the information contained in the **Safety Precautions** section before using this product.

This user manual contains information about the product and its proper use, and should be kept in a place where it will be easy to access.

User Manual Guide





This user manual contains information about the product and its proper use.

It should be kept in a place where it will be easy to access.

Please familiarize yourself with the information in this manual before using the product.

- This manual provides detailed information on the product's features. It does not offer any guarantee concerning matters beyond the scope of this manual.
- This manual may not be edited or reproduced in either part or whole without permission.
- A user manual is not provided as part of the product package.
Please visit www.autonics.com to download a copy.
- The manual's content may vary depending on changes to the product's software and other unforeseen developments within Autonics; therefore, the content of this manual is subject to change without prior notice.

User Manual Symbols

Symbol	Description
 Note	Supplementary information for a particular feature.
 Warning	Failure to follow instructions can result in serious injury or death.
 Caution	Failure to follow instructions can lead to a minor injury or product damage.
 Ex.	An example of the concerned feature's use.
※1	Annotation mark.

Safety Precautions

- Please follow safety precautions to ensure the safe and proper use of the product and prevent accidents, as well as minimizing possible hazards.
- Safety precautions are categorized as Warnings and Cautions, as defined below:

 Warning	Warning	Cases that may cause serious injury or fatal accident if instructions are not followed.
--	----------------	---

 Caution	Caution	Cases that may cause minor injury or product damage if instructions are not followed.
--	----------------	---

Warning

- In case of using this unit with machinery (Ex: nuclear power control, medical equipment, ship, vehicle, train, airplane, combustion apparatus, safety device, crime/disaster prevention equipment, etc) which may cause damages to human life or property, it is required to install fail-safe device.

It may cause a fire, human injury or damage to property.

- Always install the unit on a panel.

It may cause an electric shock if not followed.

- Never wire, repair, or inspect the unit while electricity is flowing through it.

It may cause an electric shock if not followed.

- Check the input power specifications and terminal polarity before connecting the wires.

It may cause a fire if not followed.

- Only Autonics technicians are authorized to service or modify the product.

It may cause an electric shock or fire if not followed.

Caution

- Do not use outdoors.

It may shorten the life of the product and/or cause an electric shock if not followed.

- Always use AWG 20 (0.5 mm²) or higher when wiring to the relay's output terminals.

It may pose a fire risk if not followed.

- Always use within the range of rated specifications and performance.

It may shorten the lifespan of the product and/or pose a fire risk if not followed.

- Do not allow loads in excess of the rated switching capacity on relays.

It may damage the insulation, relays and/or cause a fire or faulty connection if not followed.

- Do not use water or an oil-based solvent to clean the product. Use a dry towel instead.

It may pose an electric shock or fire risk if not followed.

- Do not use the product in a place where it is exposed to flammable or explosive gases, humidity, direct light, radiant heat, vibration, or impact.

It may pose a fire or an explosion risk if not followed.

- Do not allow dust or wiring fragments to get inside the product.

It may pose a fire or a malfunction risk if not followed.

- Check the terminal's polarity first to properly wire the temperature sensor.

It may pose a fire or an explosion risk if not followed.

Handling Precautions

These handling precautions address issues that can potentially cause the product to malfunction.

Power and Usage Environment

- Use the rated power only.
- Maintain the controller's ambient temperature between -10°C and 50°C.
- Turn the power on and allow the temperature controller to warm-up for twenty minutes before use.
- A power switch or a circuit-breaker is necessary to supply and cut off power to the product.
- Install the switch or circuit-breaker in the vicinity of the product to facilitate easy access.
- Use the product in a well-ventilated environment. Otherwise, arrange for ventilation if necessary.
- Recommended usage conditions are as follows:
 - Indoors
 - Below 2,000 m altitude
 - Pollution Degree 2
 - Installation Category II

Sensor Input

- If using in an environment where the margin of sensor error cannot be avoided, use the Input Bias feature to minimize the error margin.
- If using a thermocouple sensor, make sure to use prescribed compensation wire as extension wire. Failure to do so will produce temperature distortion at the junction between the thermocouple and the extension wire.
- If using a resistance temperature detector (RTD) sensor, always make connection with three-wire configuration. In addition, only use three wires of identical material, thickness and length if you need to extend the line. Variance in wire resistance will lead to temperature distortion.

- When changing an input sensor, first disconnect power to the product and then connect the new sensor. Restore power to the product and update the related parameters either directly from the product or using the PC loader program.
- Always use a line filter on the controller's power line. Also, use shielded wire for the input signal line, provided it is necessary for the power line and the input signal line must remain close to one another.

Noise Effect

- Isolate the product's wiring from high-voltage lines and power lines to prevent impulse noise.
- Avoid using the product in the vicinity of high-frequency noise generating devices, such as: welding machines, sewing machines, high-capacity SCR controllers, and high-capacity motors.
- Avoid using the product in the vicinity of radio, television, and wireless devices that may cause high-frequency interference.

Communication

- Only use twisted pair wires for the communication lines. Attach round ferrules at the ends of the lines to reduce the impact of external noise.
- Do not have the communication lines in close proximity of the AC power line.
- If possible, use a separate power source (24 VDC) for the communication converter (SCM-38I, sold separately).

Table of Contents

Preface	iii
User Manual Guide	iv
User Manual Symbols	v
Safety Precautions	vi
Handling Precautions	viii
Table of Contents	xi
1 Product Introduction.....	15
1.1 Features	15
1.2 Components and Accessories	16
1.3 Model Lineup	18
1.3.1 Model List and Descriptions	19
1.3.2 TM Series Related Products List (sold separately)	20
1.4 Parts and Features	21
1.4.1 Front Parts.....	21
1.4.2 Other Parts	23
2 Specifications.....	25
2.1 Ratings.....	25
2.2 Input Type	26
2.3 Input/Output Isolation.....	26
2.3.1 TM2 Series	26
2.3.2 TM4 Series	26
3 Dimensions.....	27
3.1 Installation.....	27
3.1.1 Connector Connection	27
3.1.2 Module Connection	28
3.1.3 DIN Rail Mounting	30
3.1.4 Bolts Inserting.....	32
4 Wiring Diagrams	33
4.1 TM2 Series.....	33
4.2 TM4 Series.....	34
4.3 Wiring Precautions.....	35

4.3.1	Sensor Connection	35
4.3.2	Power Supply Connection	37
4.3.3	Communication Line Wiring	37
4.3.4	Module Expansion	38
4.3.5	Basic Module Positioning	39
5	Preparation and Startup.....	41
5.1	General Process	41
5.2	Setup Values - Power On	41
5.3	Temperature Control Examples	42
5.3.1	Single Modules	42
5.3.2	Multiple Modules	44
6	Parameter Settings and Functions	45
6.1	Input	45
6.1.1	Input Type and Temperature Range	45
6.1.2	Input Type Settings	46
6.1.3	Temperature Unit Settings for Input Temperature Sensor	46
6.1.4	Input Bias Settings	47
6.1.5	Input Digital Filter	47
6.1.6	SV High/Low-limit Settings	48
6.2	Control Output	49
6.2.1	Control Output Operation Mode Settings	49
6.2.2	MV High/Low-limit Settings	55
6.2.3	Ramp Settings	56
6.2.4	Auto/Manual Control Settings	58
6.2.5	Output Settings	59
6.3	Temperature Control	61
6.3.1	Temperature Control Method Settings	61
6.3.2	ON/OFF Control	61
6.3.3	PID Control	62
6.3.4	Auto-tuning	65
6.4	Alarm Output	66
6.4.1	Alarm Output Target Channel Settings	67
6.4.2	Alarm Output Operating Mode Settings	67
6.4.3	Alarm Output Option Settings	68
6.4.4	Alarm SV setting	69
6.4.5	Alarm Output Hysteresis Settings	69
6.4.6	Alarm Output Method Settings	70
6.4.7	Alarm Output Delay Settings	71
6.4.8	Loop Break Alarm	71

6.4.9	Sensor Disconnection Alarm	74
6.4.10	Heater Disconnection Alarm.....	74
6.4.11	Alarm Output Off	76
6.4.12	Alarm Output Examples	77
6.5	Communications	80
6.5.1	Communication Exchange Number Settings	80
6.5.2	Communications Speed Settings	81
6.5.3	Communications Parity Bit Settings	82
6.5.4	Communication Stop Bit Settings.....	82
6.5.5	Response Wait Time Settings	82
6.5.6	Enable/Disable Communications Writing.....	83
6.5.7	USB-to-Serial Connection	83
6.6	Additional Features.....	84
6.6.1	Monitoring Functionality	84
6.6.2	Run/Stop.....	85
6.6.3	Multi SV	86
6.6.4	Digital Input	87
6.6.5	Error Detection	88
6.6.6	Parameter Initialization.....	89
7	Troubleshooting Tips.....	91
7.1	Error Display	91
7.2	Communication Related Tips.....	92
7.3	Control Related Tips	92
8	DAQMaster Program.....	93
8.1	Introduction	93
8.1.1	Overview	93
8.1.2	Features	94

1 Product Introduction

1.1 Features

TM series module type temperature controller realizes high-speed controlling with superior sampling cycle (TM4 – 100 ms, TM2 – 50 ms). Side connector connection makes less wiring work and close mounting possible for up to 31 units without additional power and communication wires for expansion modules. PC parameter setting and monitoring is possible via RS485 communication or dedicated USB cable. In addition, more reliable temperature controlling can be realized via various convenient functions.

- Max. 124 channel simultaneous controlling possible
- Each channel insulated – Dielectric strength 1,000VAC
- No communication and power supply for expansion modules required using module connectors : Up to 31 module (124 channels/62 channels) expansion possible
- High-speed sampling cycle (TM4:100 ms/TM2:50 ms)
- Heating/Cooling simultaneous controlling
- Heater Burn-Out detection via a current transformer (CT).
- PC parameter setting via USB cable and RS485 communication (Modbus RTU)
 - : DAQ-MASTER / ParaSet - PC loader program supported
 - : Dedicated USB cable - no separate power supply or connections required
- Easy maintenance via connector type connection
 - : Sensor input connector, control output connector, power/communication connector
- Multi-input/multi-range
- Applications: hot runners, electronic furnace, reflow, catapult and extruders

1.2 Components and Accessories

(1) Components

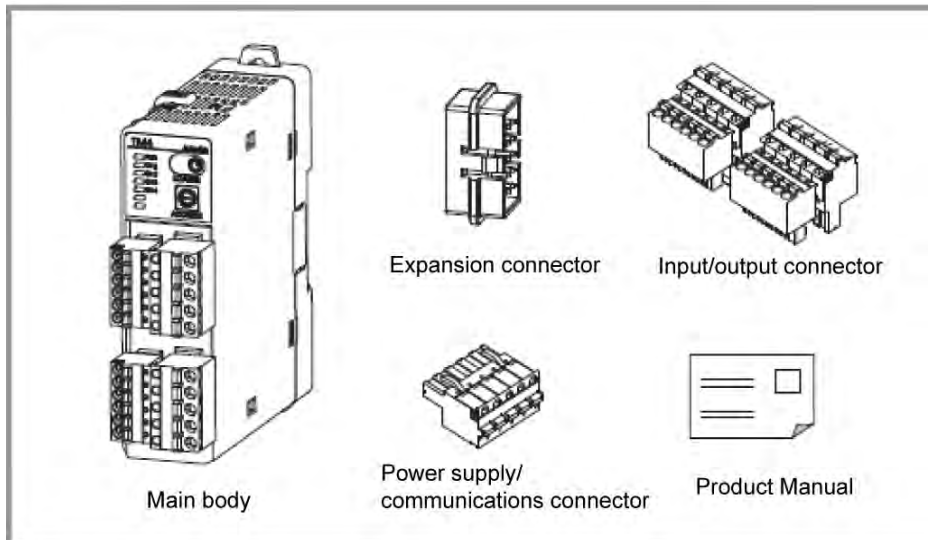

Note

- Make sure all listed components are included with your product before use. If any components are missing or damaged, please contact our sales department or your dealer.
- Note that power supply/communications connectors are provided with basic modules only.
- Please download the user manual from our website (www.autonics.com).

(2) Accessories (sold separately)

- Converter

SCM-38I (RS232C to RS485 converter)	SCM-US48I (USB to RS485 converter)	SCM-US(USB to Serial converter)
		

- Current transformer(CT)

CSTC-E80LN

Current measuring range: 100mA to 80A($R_b=10\Omega$),
 Wire wound resistance: $31\Omega \pm 10\%$, Current ratio: 1000:1,
 Accuracy: 2.0 grade(5A to 8A)

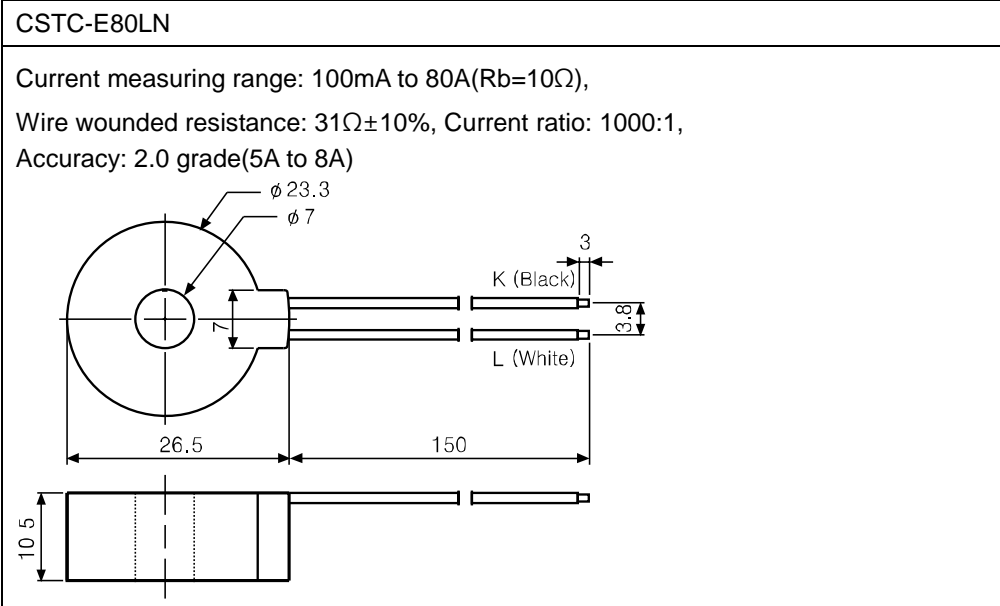

CSTC-E200LN

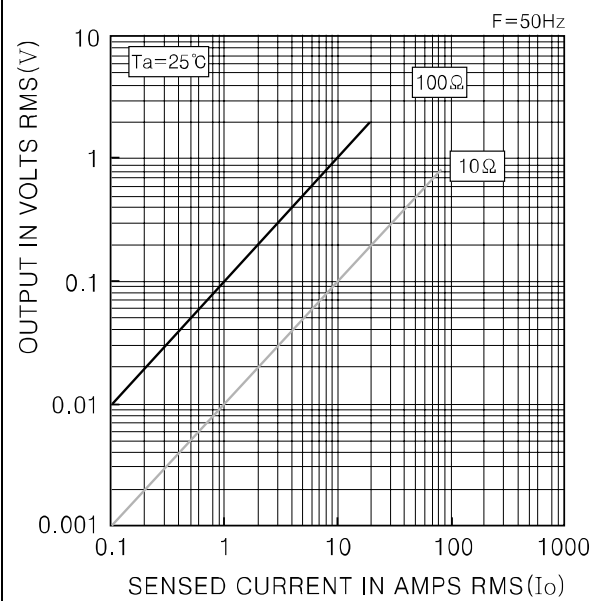

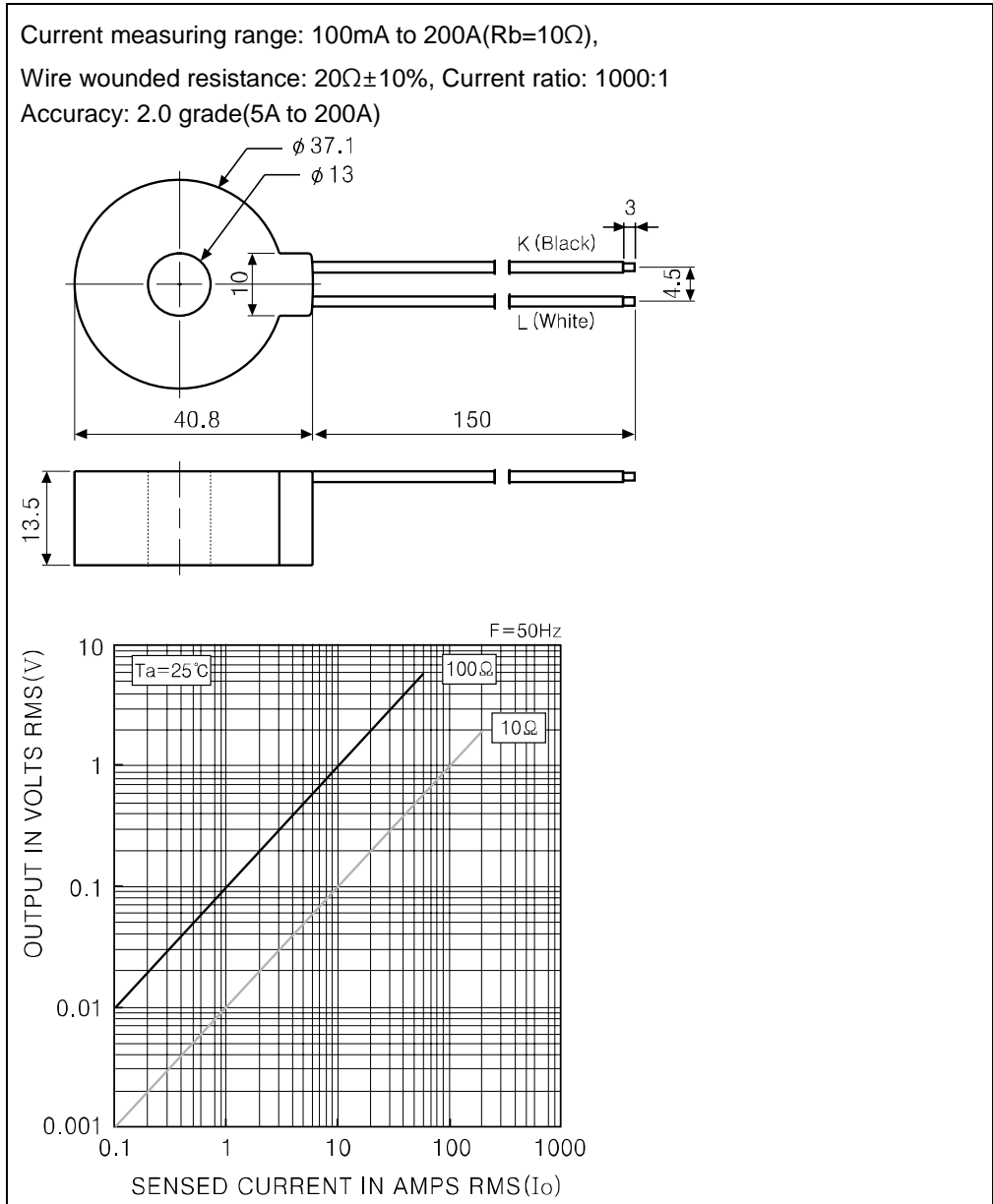

 <p>Note</p>	<ul style="list-style-type: none"> • Images of components and accessories may differ from actual products. • For detailed information about any of the above products, please refer to the concerned product's user manual. • Please download the user manual from our website (www.autonics.com)
--	--

1.3 Model Lineup

TM 4 - N 2 R B

①		②		③		④		⑤		⑥	
Category				Description							
① Model				TM	Multi-channel modular temperature controller						
② Channels				2	2-channel						
				4	4-channel						
③ Auxiliary Input/Output		2-channel		2	Alarm 1 + alarm 2 relay output						
				4	Alarm 1 + alarm 2 + alarm 3 + alarm 4 relay output						
③ Auxiliary Input/Output		4-channel		N	None (※No auxiliary input/output)						
				④ Power supply				2	24 VDC		
⑤ Control Output		2-channel		R	Relay output						
				C	Select either current or SSR output						
		4-channel		R	Relay output						
				S	SSR output						
⑥ Module type※ ¹				B	Basic module						
				E	Expansion module						

※1: Note that power supply/communications connectors are provided with basic modules only. Make sure to purchase both expansion module and basic module together since power supply/communication terminals are provided with basic modules only.

1.3.1 Model List and Descriptions

	Model Name	Control Output	Sub Output	Structure
TM2 Series※ ¹	TM2-22RB	Relay output	Alarm 1 + 2 relay output	Basic module
	TM2-22CB	Current or SSR output	Alarm 1 + 2 relay output	
	TM2-42RB	Relay output	Alarm 1 + 2 + 3 + 4 relay	

	Model Name	Control Output	Sub Output	Structure
			output	Expansion module
	TM2-42CB	Current or SSR output	Alarm 1 + 2 + 3 + 4 relay output	
	TM2-22RE	Relay output	Alarm 1 + 2 relay output	
	TM2-22CE	Current or SSR output	Alarm 1 + 2 relay output	
	TM2-42RE	Relay output	Alarm 1 + 2 + 3 + 4 relay output	
	TM2-42CE	Current or SSR output	Alarm 1 + 2 + 3 + 4 relay output	
TM4 Series	TM4-N2RB	Relay output	-	Basic module
	TM4-N2SB	SSR output	-	
	TM4-N2RE	Relay output	-	Expansion module
	TM4-N2SE	SSR output	-	

※1: For TM2 Series, the current transformer (C·T) input and digital input (DI) are provided.

1.3.2 TM Series Related Products List (sold separately)

Model	Description
SCM – 38I	A converter that switches RS485 signal to RS232.
SCM – US	A converter that switches serial signal to USB signal.
SCM-US48I	A converter that switches RS485 signal to USB signal.
GP – S044/S057/S0770	Graphics panel
LP-S044/S070	Logic panel
SPC1	SCR power regulator (35 A, 50 A)
SPA-030-24	Power supply, 30 W 1.5 A
SPA-050-24	Power supply, 50 W 2.1 A
SPA-075-24	Power supply, 75 W 3.2 A
SPA-100-24	Power supply, 100 W 4.2 A

1.4 Parts and Features

1.4.1 Front Parts

1.4.1.1 TM2 Series (2-channels)

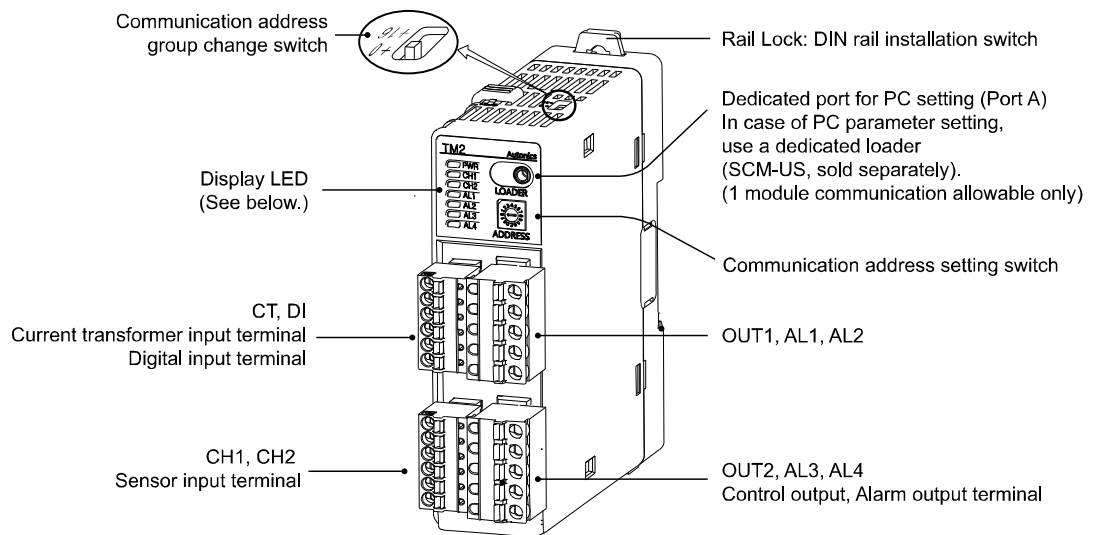

Indicating LED

Status Indicating LED	Initial power-on ^{※1}	Control output	Alarm output				Auto-tuning ^{※2}
			N.O Alarm occurred		N.C Alarm occurred		
			OFF(OPEN)	ON(CLOSE)	OFF(CLOSE)	ON(OPEN)	
PWR LED ^{※3}	Green	Green	-	-	-	-	Green
CH1 LED	2,400bps-Flickering	ON-Red	-	-	-	-	Flashes
CH2 LED	4,800bps-Flickering	ON-Red	-	-	-	-	Flashes
AL1 LED	9,600bps-Flickering	ON-Yellow ^{※4}	Light OFF	Light ON	Light OFF	Light ON	OFF
AL2 LED	19,200bps-Flickering	ON-Yellow ^{※5}	Light OFF	Light ON	Light OFF	Light ON	OFF
AL3 LED	38,400bps-Flickering	-	Light OFF	Light ON	Light OFF	Light ON	OFF
AL4 LED	-	-	Light OFF	Light ON	Light OFF	Light ON	OFF

- ※1: In case of initial power on, default communication speed will be flickering for 5 sec (1 sec cycle).
- ※2: Each CH□ LED will be flickering during auto tuning(1 sec cycle).
- ※3: PWR LED will be flickering while communicating with external units(1 sec cycle).
- ※4: Light ON when control type for CH1 is heating & cooling type and cooling output is provided(Alarm setting not available on AL1).

- ※5: Light ON when control type for CH2 is heating & cooling type and cooling output is provided (Alarm setting not available on AL2).
Please see "Chapter 7, Simple Troubleshooting Tips" for errors indication.

1.4.1.2 TM4 Series (4-channel)

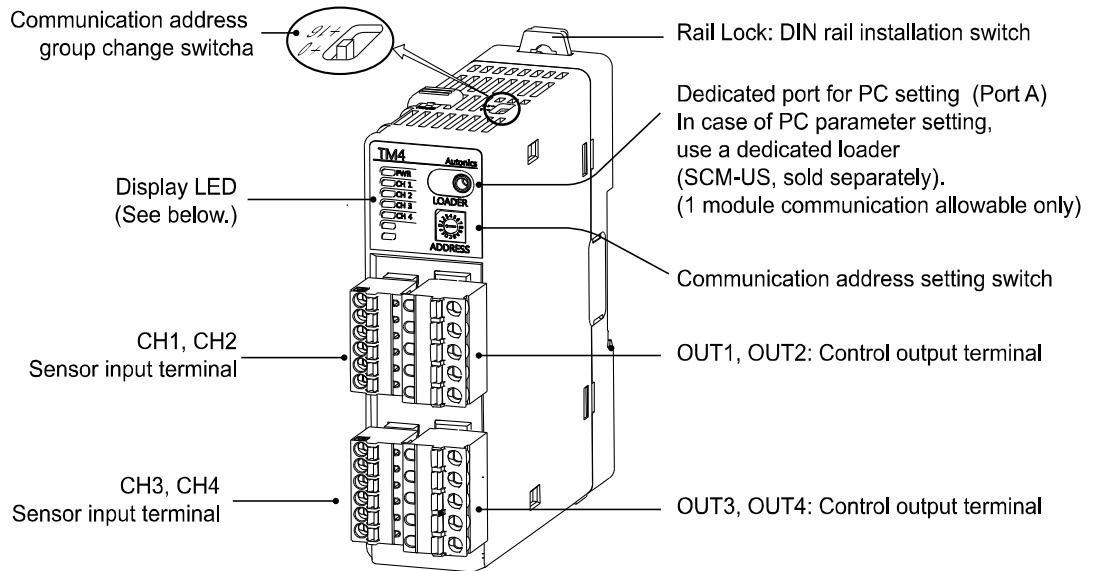

Indicating LED

Indicating LED \ Status	Initial power-on ^{※1}	Control output	Auto-tuning ^{※2}
PWR LED ^{※3}	Green	Green	Green
CH1 LED	2,400bps-Flickering.	ON-Red	Flickering
CH2 LED	4,800bps-Flickering.	ON-Red	Flickering
CH3 LED	9,600bps-Flickering.	ON-Red	Flickering
CH4 LED	19,200bps-Flickering.	ON-Red	Flickering
	38,400bps-Flickering.	-	-
	-	-	-

- ※1: In case of initial power on, default communication speed will be flickering for 5 sec (1 sec cycle).
- ※2: Each CH□ LED will be flickering during auto tuning(1 sec cycle).
- ※3: PWR LED will be flickering while communicating with external units(1 sec cycle).

Please refer to "Chapter 7, Simple Troubleshooting Tips" for error indication.

1.4.2 Other Parts

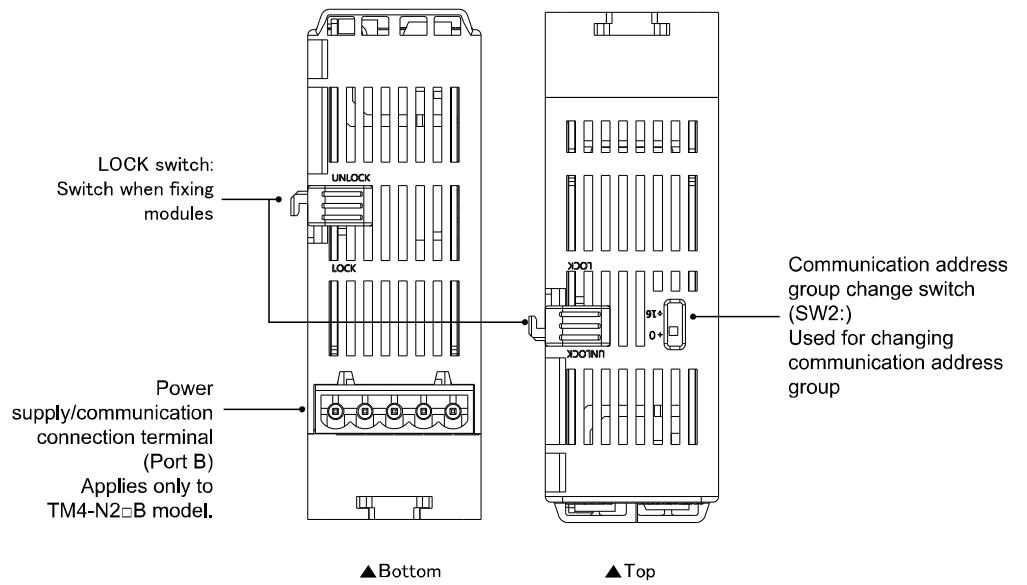
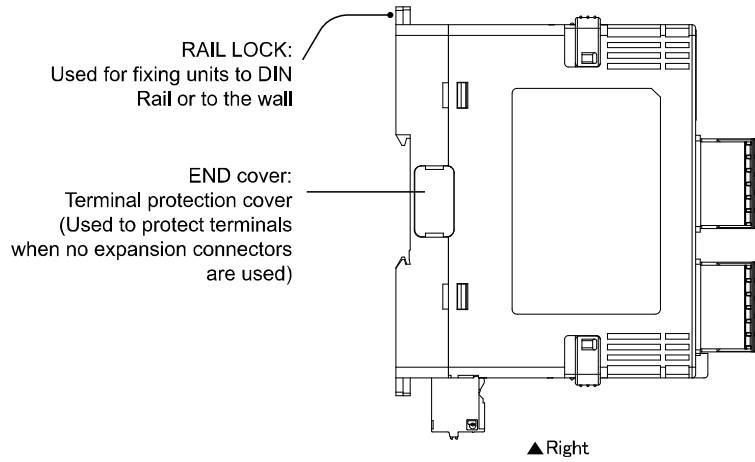

2 Specifications

2.1 Ratings

Category		TM2 Series	TM4 Series
Number of Channels		2 channels	4 channels
		Each channel insulated – Dielectric strength 1,000VAC	
Power Supply		24VDC	
Allowable voltage range		90% ~ 110% of rated voltage	
Power Consumption		5W max. (At maximum load)	
Indicating type		Non indicating type - Parameter setting and monitoring with externally device (PC or PLC).	
Input type	RTD	DPt100 Ω, JPt100 Ω 3 wire (allowable line resistance: Max. 5Ω)	
	Thermocouples	K, J, E, T, L, N, U, R, S, B, C, G, and PLII (13types)	
Indicating accuracy	RTD	(Bigger one either PV±0.5% or ±1°C)±1 Digit Max.	
	Thermocouple※1		
	C-T Input	(±5% F.S.) ±1 Digit Max	-
	Current output	(±1.5% F.S.) ±1 Digit Max	-
Influence of Temperature※2	RTD	(Bigger one either PV±0.5% or ±2°C)±1 Digit Max.(In case of thermocouple input, it is ±5°C at -100°C below) Thermocouples L, U, C, G, R, S, B: (Bigger one either PV±0.5% or ±5°C)±1 Digit Max.	
	Thermocouples		
Control Output	Relay	250VAC 3 A 1a	
	SSR	12VDC ±3V 30mA Max.	22VDC ±3V 30mA Max.
	Current	DC4-20mA or DC0-20mA (Load 500ΩMax.)	-
Sub Output	Relay	250VAC 3 A 1a	
Communications output		RS485 communications output (Modbus RTU method)	
Event Input	Leakage current	Approx. Max. 4mA	-
	Contact	ON: Max. 1KΩ, OFF: Min. 100KΩ.	-
	Non-contact	ON: Max. 1.5V residual voltage OFF: Max. 0.1mA leakage current	-
	C-T	0.0-50.0A (Primary current measurement range) ※C-T ratio (1000:1)	-
Control type	Heating, Cooling	ON/OFF control, P, PI, PD, PID control	
	Heating & Cooling		
Hysteresis		RTD/ Thermocouples: 1~100°C/°F(0.1~100.0°C/°F) variable	
Proportional Band (P)		0.1 ~ 999.9°C	

Category		TM2 Series	TM4 Series
Integral Time (I)		0 ~ 9999 sec.	
Derivative Time (D)		0 ~ 9999 sec.	
Control Period		0.1 ~ 120.0 sec. (Only relay and, SSR output type)	
Manual Reset Value		0.0 ~ 100.0%	
Sampling period		50 ms (2 channel simultaneous sampling)	100 ms (4 channel simultaneous sampling)
Dielectric Strength		1000 VAC, 50/60Hz for 1 minute (between power source terminal and input terminal)	
Vibration Resistance		5 to 55 Hz (1 min. interval), 0.75 mm double amplitude for 2 hours each in X, Y, and Z directions.	
Relay Life Cycle	Mechanical	Over 10,000,000 cycles	
	Electrical	Over 100,000 cycles (250VAC 3 A resistance load)	
Insulation Resistance		100 MΩ (at 500VDC megger)	
Noise Resistance		Square wave noise by noise simulator (pulse width 1μs) ±0.5 kV	
Environment	Ambient Temperature	-10~50°C, Storage temperature: -20~60°C	
	Ambient Humidity	35~85%RH, Storage humidity: 35~85%RH	
Accessories		Expansion connectors	
		Power supply/communications connector (※Included with basic module only)	
Insulation type ^{※3}		□	
Approved Standards		CE, UL	
Unit Weight		Approx. 135 to 152g	Approx. 135 to 152g

※1: In case of thermocouple K, T, N, J, E at -100°C below and L, U, Platine II, it is 2°C±1 Digit Max. In case of thermocouple B, indicating accuracy cannot be ensured under 400°C. In case of thermocouple R, S at 200°C below and thermocouple C, G, it is 3°C±1Digit Max.

※2: Applied when used out of range 23±5°C.

※3: "□" mark indicates that equipment protected throughout by double insulation or reinforced insulation.

※Condition for use in environment is no freezing or condensation.

※Weights by model are shown in the following table.

Model Name	Weight	Model Name	Weight	Model Name	Weight
TM2-22RB	Approx. 144 g	TM2-22CB	Approx. 139 g	TM4-N2RB	Approx. 174 g
TM2-42RB	Approx. 152 g	TM2-42CB	Approx. 148 g	TM4-N2RE	Approx. 166 g
TM2-22RE	Approx. 135 g	TM2-22CE	Approx. 130 g	TM4-N2SB	Approx. 160 g
TM2-42RE	Approx. 143 g	TM2-42CE	Approx. 139 g	TM4-N2SE	Approx. 152 g

3 Dimensions

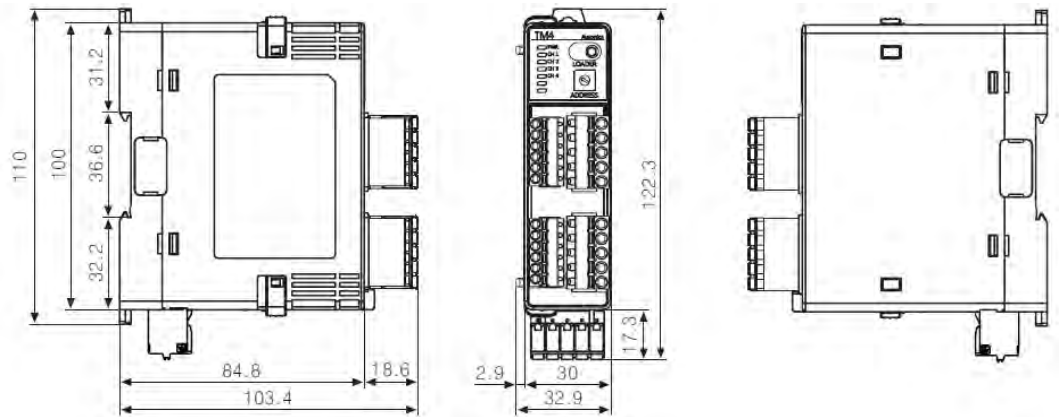

	<p>Note Expansion modules do not have a power supply/communications connection terminal at the bottom.</p>
---	---

3.1 Installation

3.1.1 Connector Connection

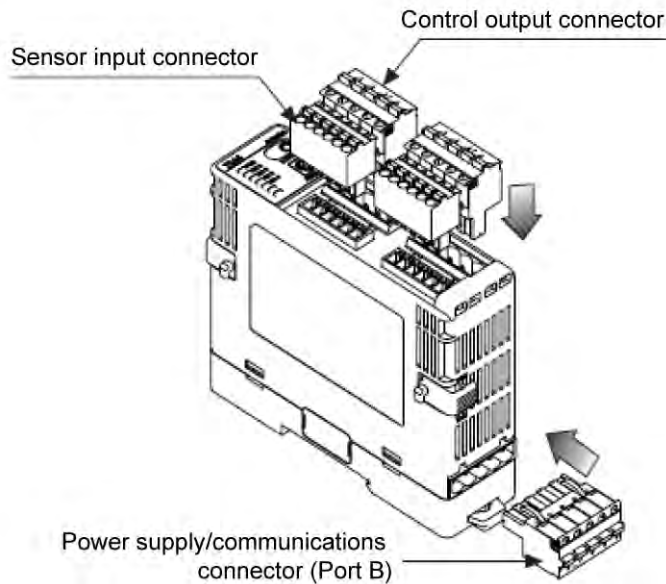

	<p>Note Expansion modules do not have a power supply/communications connection terminal.</p>
---	---

3.1.2 Module Connection

TM series allows simultaneous monitoring for multi channel I/O with connecting multiple modules using module expansion connectors. Connect expansion modules to a basic module. Basic module can be placed in any position among multiple module sets.

Remove the cover.

- 1 Remove END cover for both basic modules and expansion modules.
- 2 Insert expansion module connection connectors.
- 3 Connect an expansion module without space.
- 4 Fix the LOCK switch by pushing it in the LOCK direction.
- 5 Mount the END cover at each side.

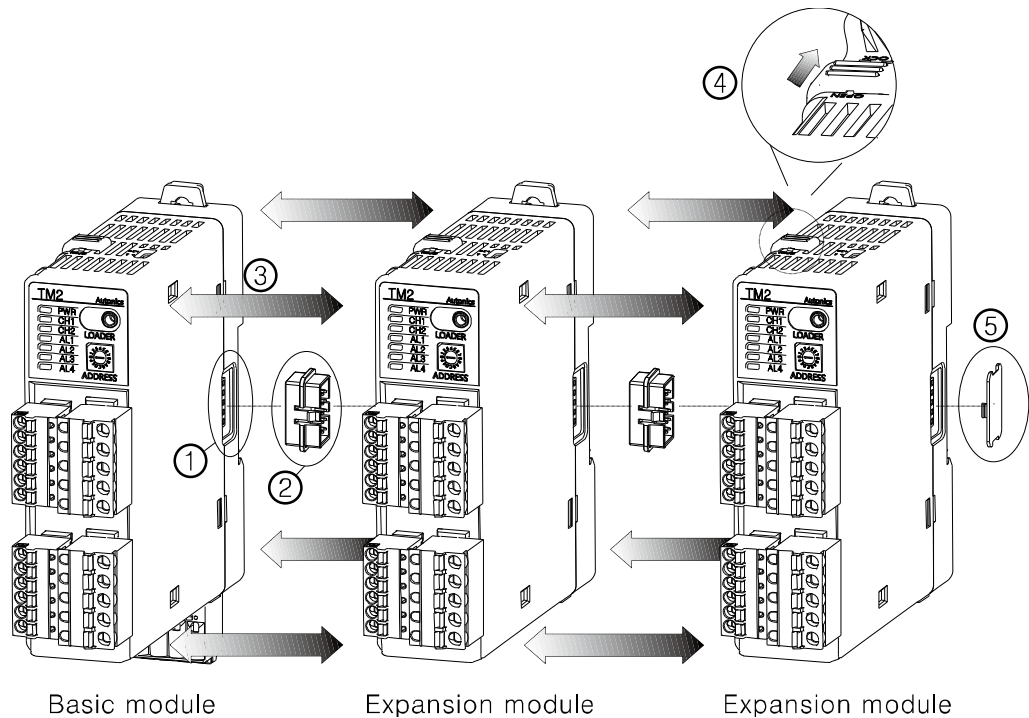



Note

Up to 30 expansion modules can be connected to a basic module. However, use an adequate power supply system for the power input specifications and overall capacity.

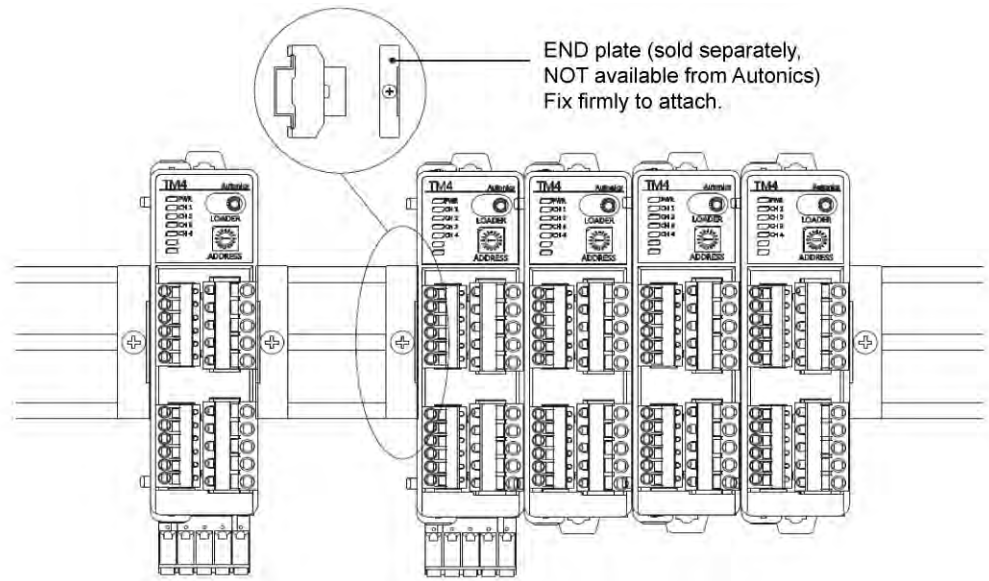
6 Mount the DIN rail vertically.

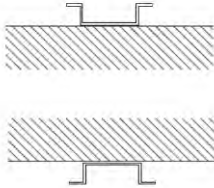

 <p>Note</p>	<p>Mount the product vertically. Mounting horizontally may reduce accuracy.</p>	
	 <p>▲ Vertical mounting (O)</p>	 <p>▲ Horizontal mounting (X)</p>

3.1.3 DIN Rail Mounting

(1) Installation/Removal method of a single module

1) Installation method

- ① Put the top edge of the rail lock on the top edge of the DIN rail.
- ② Push the module body in while pressing down.

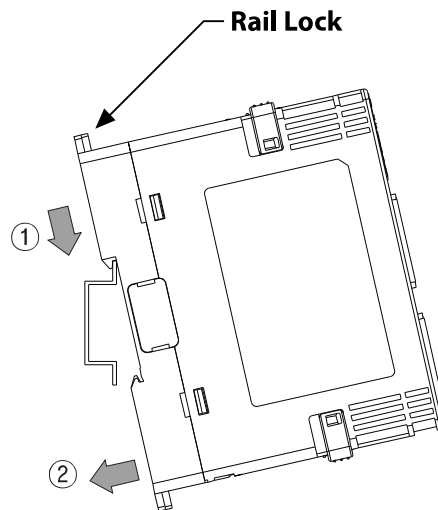

2) Removal method

- ① Press down the module body.
- ② Pull the module body forward.

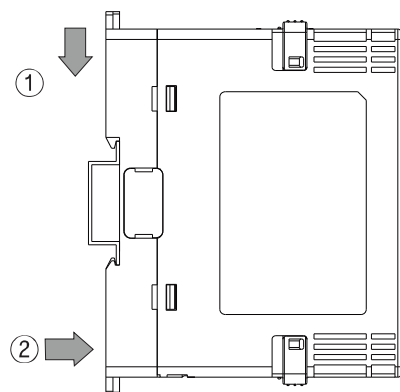

(2) For multiple modules

1) Installation method

- ① Pull each Rail Lock switch up and down.
- ② Mount the module body to the DIN rail and then push the rail lock in.

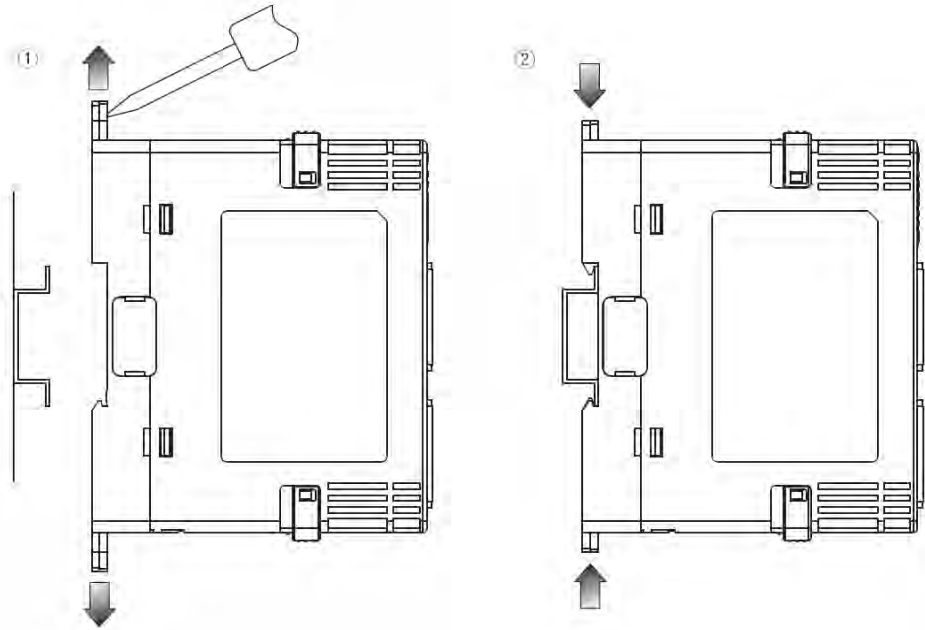

2) Removal method

- ① Pull each Rail Lock switch up and down.
- ② Remove the body from the DIN rail.

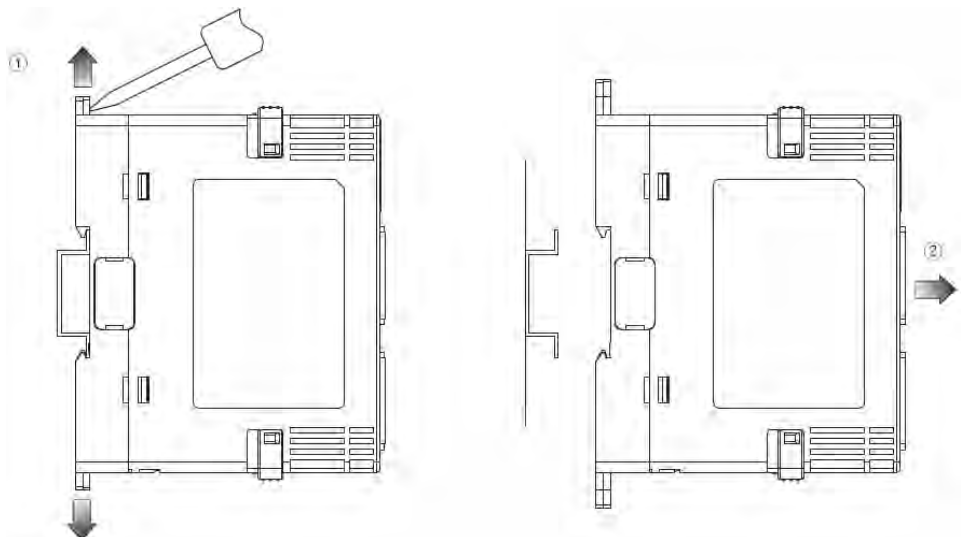

3.1.4 Bolts Inserting

- ① Pull each Rail Lock switch up and down.

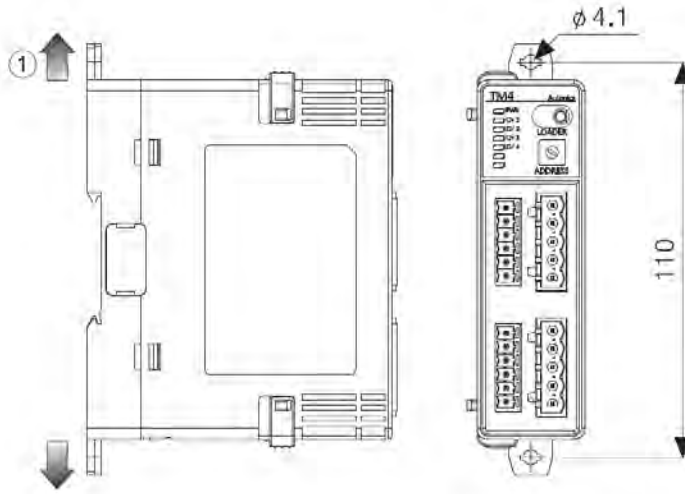

- ② Insert the bolts to fix (tightening torque: 0.5 to 0.9 N•m).

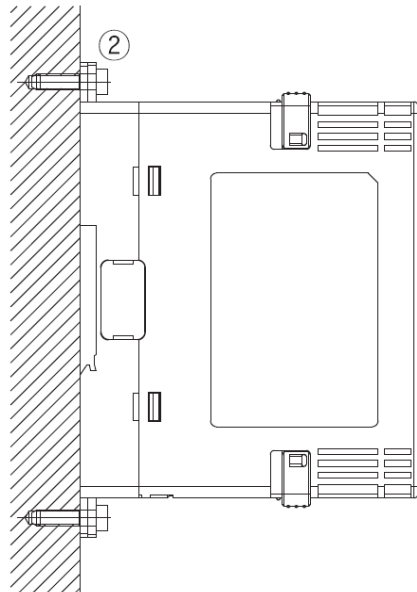

4 Connections and block diagram

(1) TM2 series

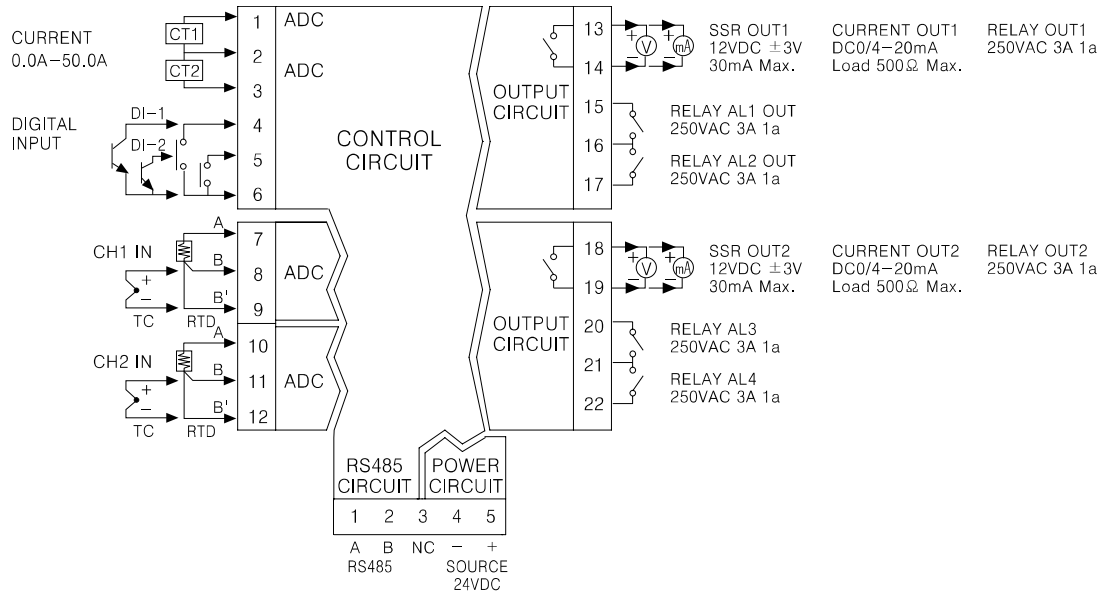

※USB to Serial communication (Port B) is insulation structure as same as RS485 communication (Port A).

※Relay AL3 OUT, Relay AL4 OUT are available only for TM2-42□□ models.

(2) TM4 series

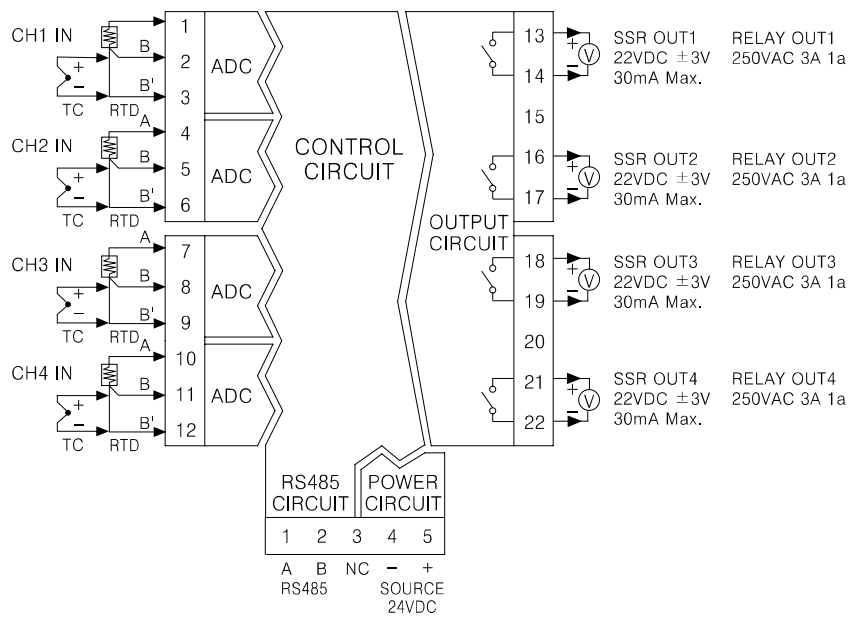

※USB to Serial communication (Port B) is insulation structure as same as RS485 communication (Port A).

(3) Example of connection

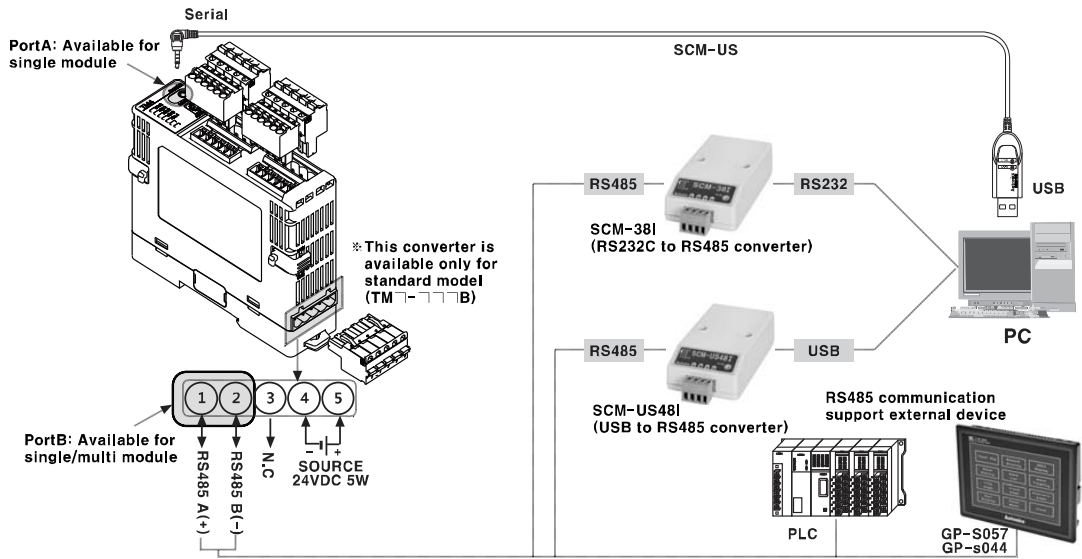

4.1 TM4 Series

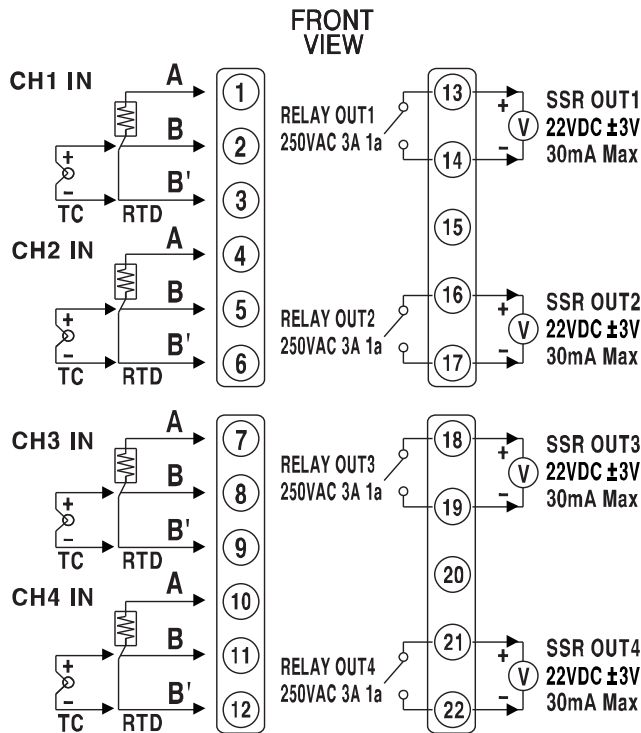

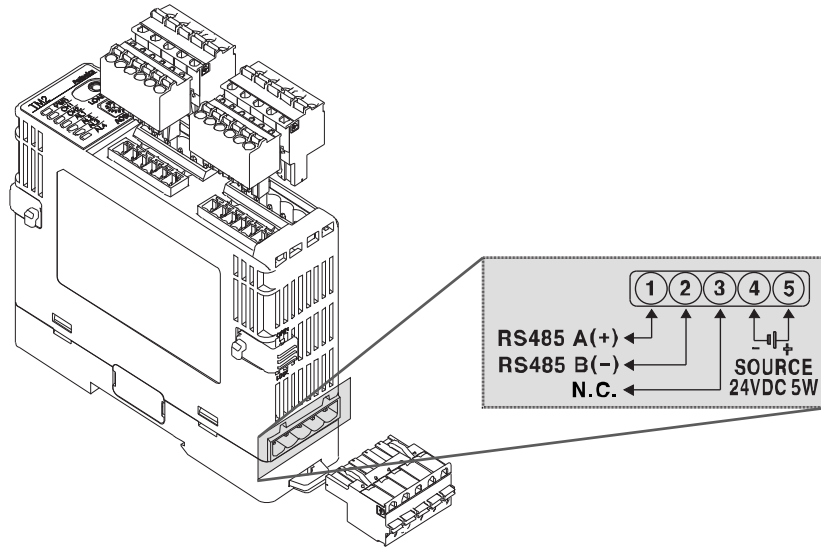

Shaded terminals are available only for TM4-N2□B

 Note	<ul style="list-style-type: none"> • Pay attention to the connection direction when wiring the power supply/communications connection terminal. • It is recommended to use lines with AWG 28 to 16 when connecting the sensor or compensation wire. • It is recommended to use lines thicker than AWG 24 for SSR output. • It is recommended to use lines thicker than AWG 20 for relay output.
--	---

4.2 Wiring Precautions

- Mixing up the input terminals with output terminals and vice versa can lead to product damage.
- Use only sensors supported by the product.
- Make sure to connect rated SSRs or loads to the output terminals.
- Make sure to connect the communication cable with correct communication terminals (A, B).
- Make sure to observe correct polarity of power source terminals. (+ and -).

4.2.1 Sensor Connection

4.2.1.1 Compensation Wire Connection

For thermocouple sensors, use compensation wire of the same specification as input sensors. Using an extension wire of different specification and/or material will increase

inaccuracy of temperature sensing. It is recommended to choose high performance compensation wire for more reliable sensing.

4.2.1.2 Measurement Error

- Do not mix up the direction of the input sensor connector.
- Carefully adjust both load and sensor positions.
- Make sure the sensor is securely attached to the input connector.

4.2.1.3 Wiring with AC Power Lines

Do not put the sensor lines in close proximity of the AC power lines.

4.2.1.4 Input Sensor (or compensating lead wires) Connection

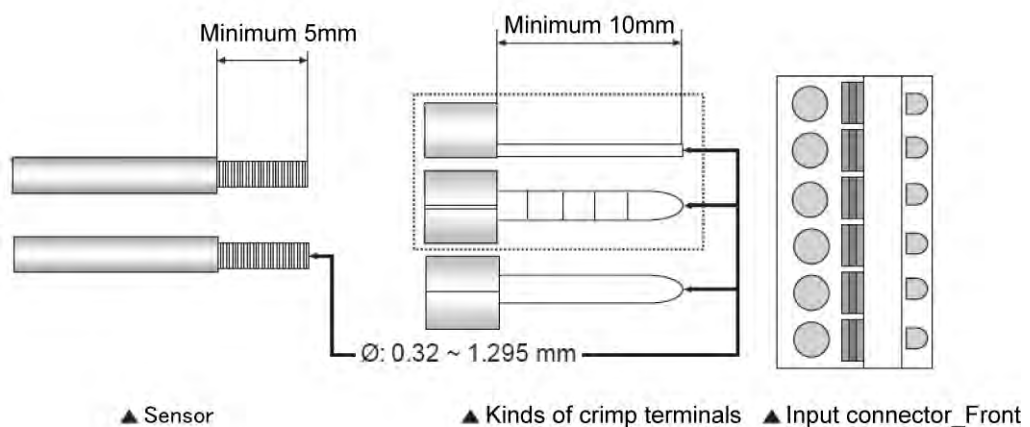

Note

- Make sure the sensor is completely inserted in the connector using a crimped terminal.
- The sensor and crimp terminal to attach at the input connector must be AWG 28 to 16 (Ø: 0.32 to 1.295 mm).
- Fix the sensor to the connector properly for accurate measurement.

4.2.2 Power Supply Connection

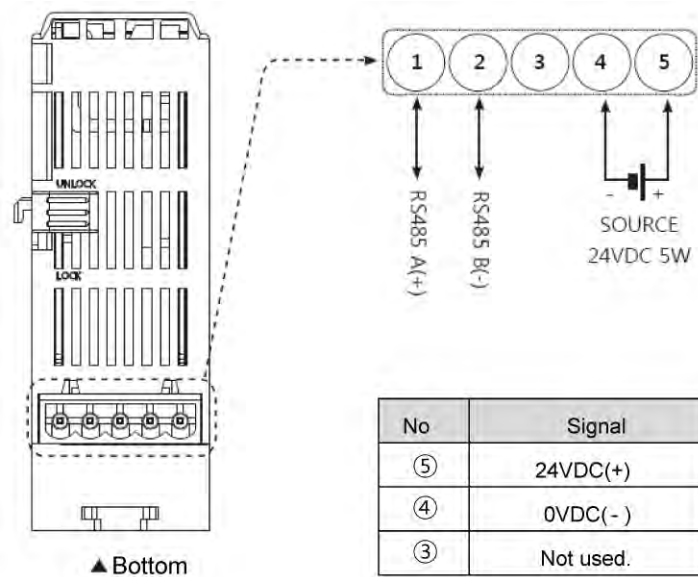

Note

- Use power line with AWG 24 to 12.
- Calculate the total power consumption first and then connect a power supply system of appropriate capacity.

4.2.3 Communication Line Wiring

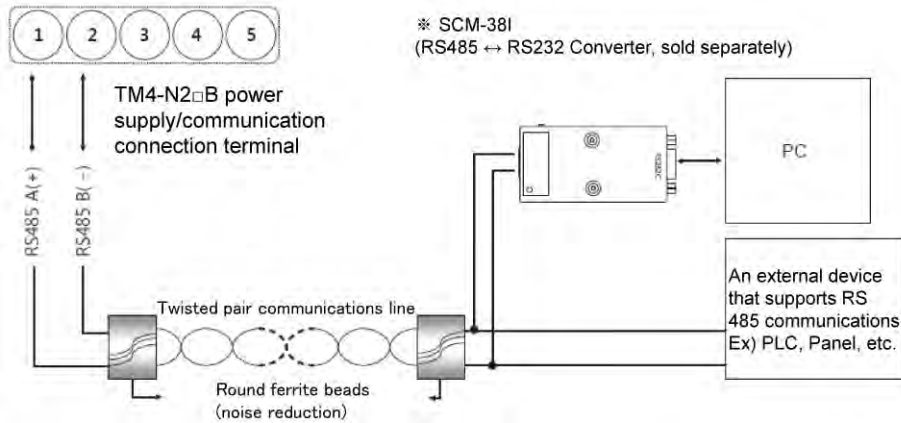

Note

- Do not tie the communications line together with the AC power line.
- Use twisted pair cables for the communications line only.
- Do not allow the communication line to exceed 800 m in length.
- For further details, please refer to '6-5, Communications' on page 61.

4.2.4 Module Expansion

When using the bottom power supply/communication connection terminal (Port B), up to 31 modules can be connected at the same time.

Maximum required power = 31 X 5 W = 155 W

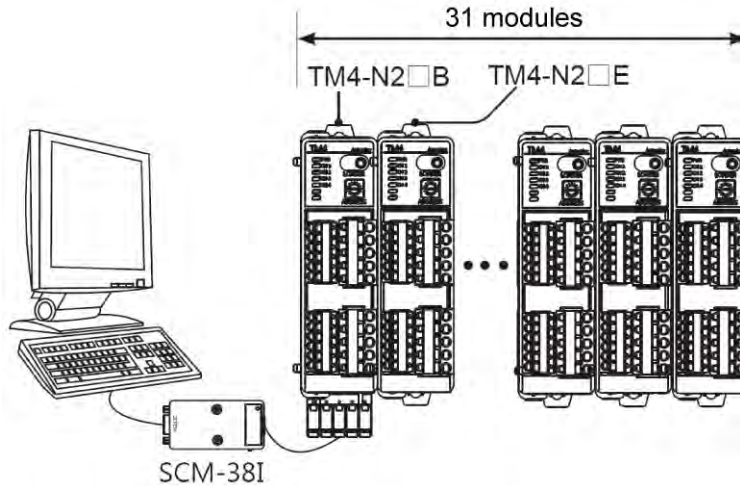

When connecting several module sets (31 modules or less), each module set requires separate power supply.

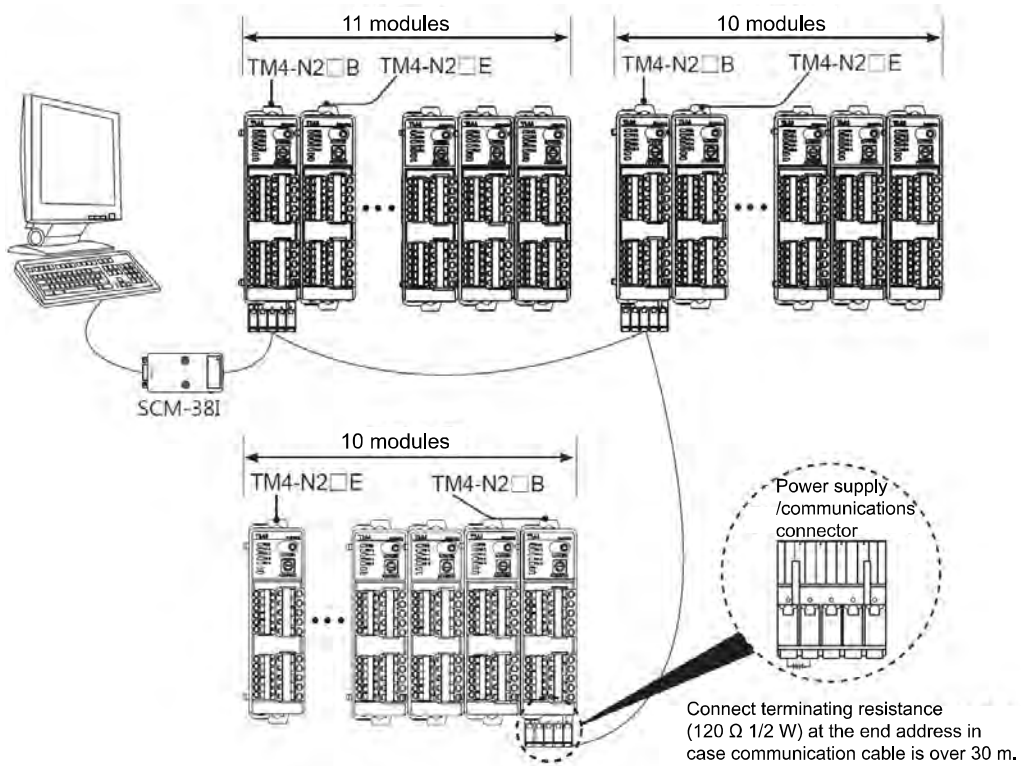

4.2.5 Basic Module Positioning

The basic module can be mounted anywhere in the connected group. It works regardless of communication address.

Basic module

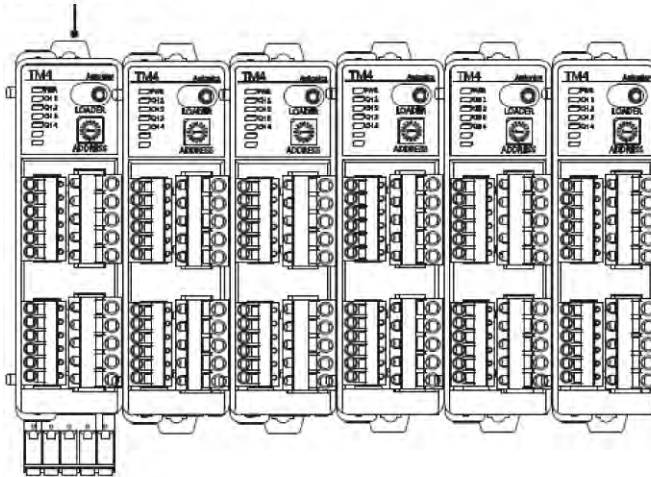

Basic module

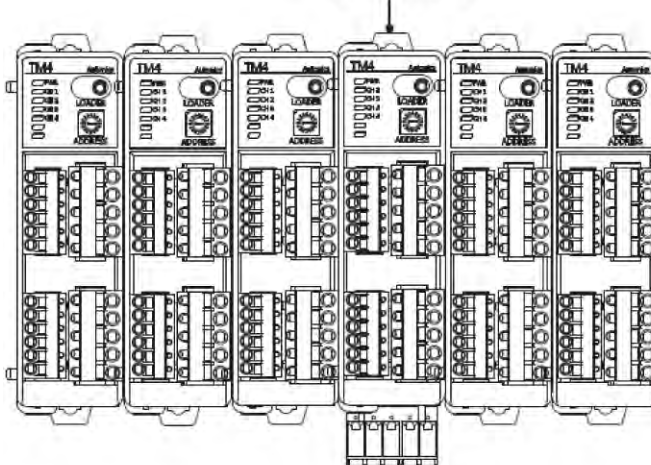

5 Preparation and Startup

5.1 General Process

Before operating TM Series for the first time, do the following:

- 1 Connect all external devices, sensor and load to the TM Series.
- 2 Set parameter values through external connecting devices (PC loader program, GP etc.).
- 3 Download the parameters to TM Series.
- 4 Proceed with auto-tuning or set control variables, and then start control.



Note

If you use the “DAQMaster” program, parameters are automatically downloaded at the time when they are changed.

5.2 Setup Values - Power On

Setting Category	Factory Default	Previous Value	Power ON Value
Auto/Manual	Auto	Auto	Auto
		Manual	Manual
RUN/STOP	RUN	RUN	RUN
		STOP	STOP
PID/ONOFF	PID	PID	Maintains preset value
		ONOFF	Maintains preset value
MV	0.0	Preset MV	Maintains preset value
	0.0	Stop MV	Maintains preset value
	0.0	Sensor Error MV	Maintains preset value

5.3 Temperature Control Examples

5.3.1 Single Modules

5.3.1.1 TM4-N2RB Model (relay output)

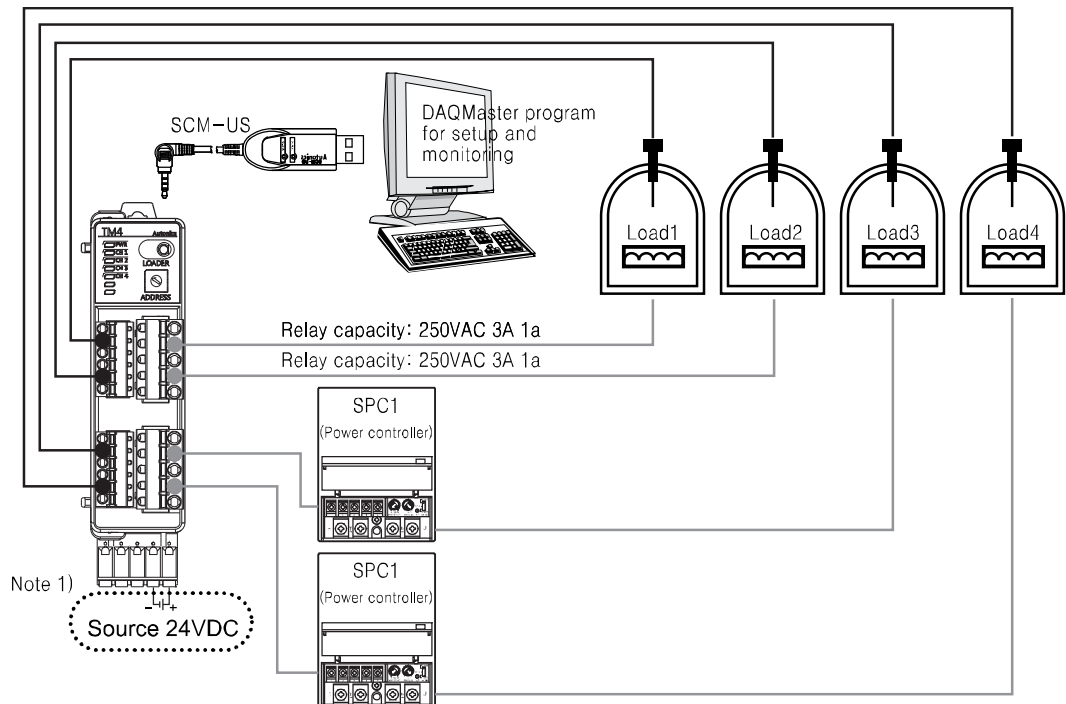

- Note 1) Using SCM-US enables only setting parameter. To monitor and control temperature requires the additional 24VDC power supply.

 Caution	Do not connect SCM-US and RS485 communications cables at the bottom at the same time.
--	---

5.3.1.2 TM4-N2SB Model (SSR output)

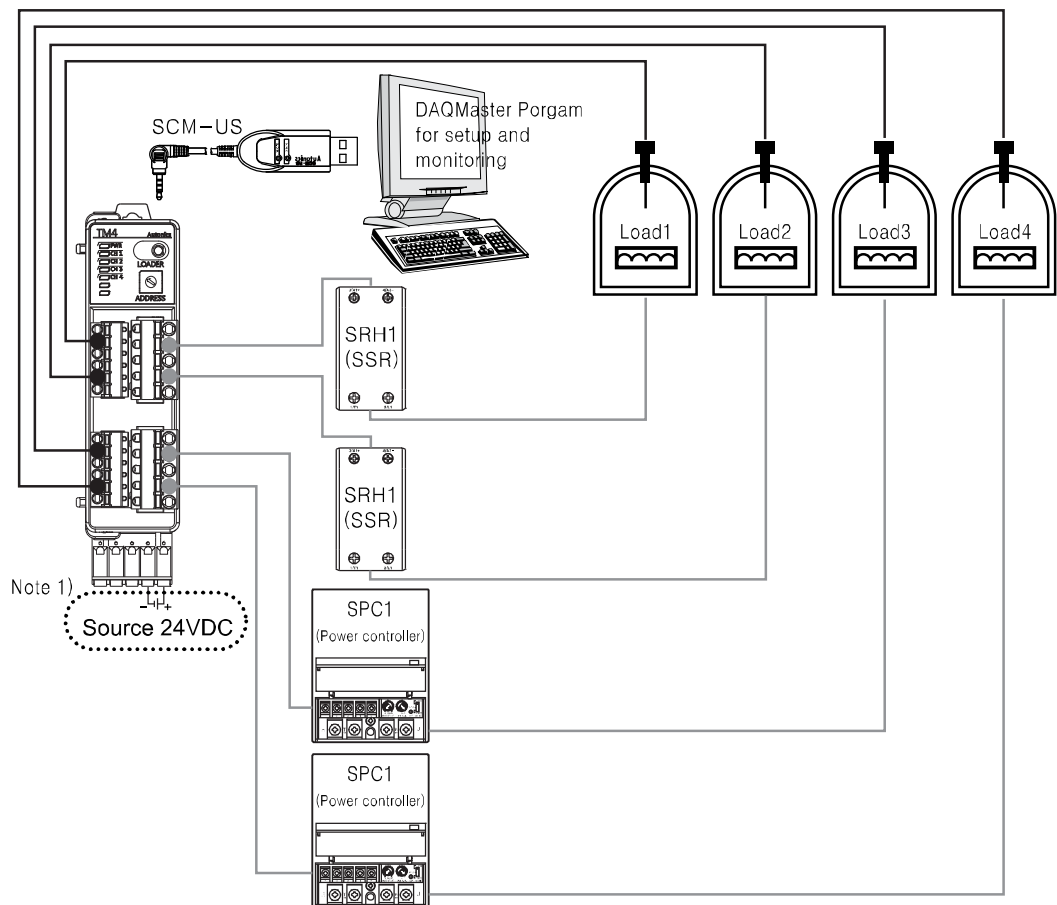

- Note1) Using SCM-US enables only setting parameter. To monitor and control temperature requires the additional 24VDC power supply.

**Caution**

- Do not connect SCM-US and RS485 communications cables at the bottom at the same time.
- Use an isolated type SSR.

5.3.2 Multiple Modules

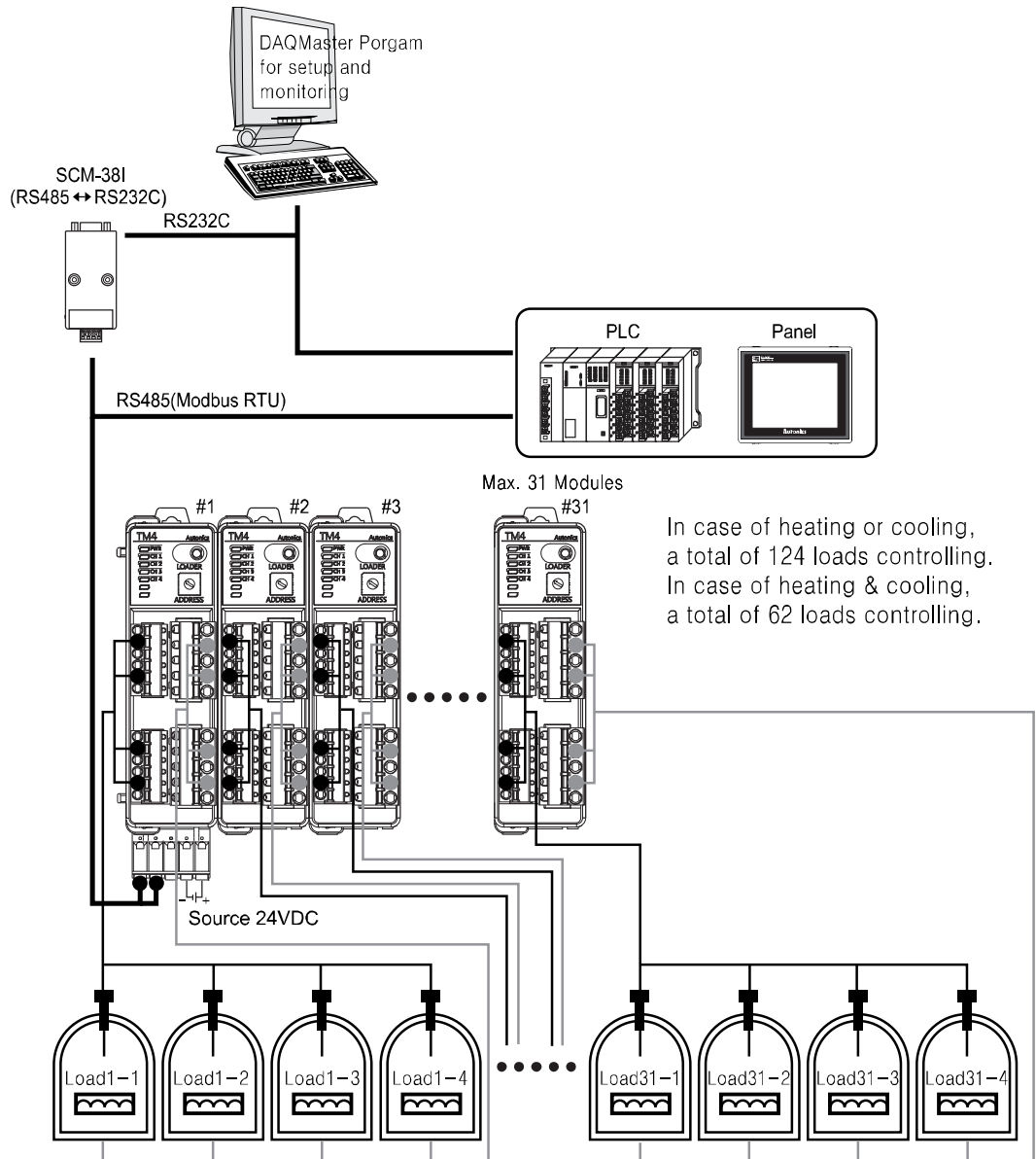

6 Parameter Settings and Functions

6.1 Input

6.1.1 Input Type and Temperature Range

Input Type		No.	Decimal Point	Indicator	Temperature range (°C)	Temperature range (°F)
Thermocouples (Thermo-Couple)	K(CA)	0	1	K(CA).H	-200 ~ 1350	-328 ~ 2462
		1	0.1	K(CA).L	-200.0 ~ 1350.0	-328.0 ~ 2462.0
	J(IC)	2	1	J(IC).H	-200 ~ 800	-328 ~ 1472
		3	0.1	J(IC).L	-200.0 ~ 800.0	-328.0 ~ 1472.0
	E(CR)	4	1	E(CR).H	-200 ~ 800	-328 ~ 1472
		5	0.1	E(CR).L	-200.0 ~ 800.0	-328.0 ~ 1472.0
	T(CC)	6	1	T(CC).H	-200 ~ 400	-328 ~ 752
		7	0.1	T(CC).L	-200.0 ~ 400.0	-328.0 ~ 752.0
	B(PR)	8	1	B(PR)	0 ~ 1800	32 ~ 3272
	R(PR)	9	1	R(PR)	0 ~ 1750	32 ~ 3182
	S(PR)	10	1	S(PR)	0 ~ 1750	32 ~ 3182
	N(NN)	11	1	N(NN)	-200 ~ 1300	-328 ~ 2372
	C(TT) ※ ¹	12	1	C(TT)	0 ~ 2300	32 ~ 4172
	G(TT) ※ ²	13	1	G(TT)	0 ~ 2300	32 ~ 4172
	L(IC)	14	1	L(IC).H	-200 ~ 900	-328 ~ 1652
		15	0.1	L(IC).L	-200.0 ~ 900.0	-328.0 ~ 1652.0
U(CC)	16	1	U(CC).H	-200 ~ 400	-328 ~ 752	
	17	0.1	U(CC).L	-200.0 ~ 400.0	-328.0 ~ 752.0	
Platinel II	18	1	PLII	0 ~ 1400	32 ~ 2552	
Platinum Resistance Temperature Detector (RTD)	JPt100 Ω	19	1	JPt100.H	-200 ~ 600	-328 ~ 1112
		20	0.1	JPt100.L	-200.0 ~ 600.0	-328.0 ~ 1112.0
	DPt100 Ω	21	1	DPt100.H	-200 ~ 600	-328 ~ 1112
		22	0.1	DPt100.L	-200.0 ~ 600.0	-328.0 ~ 1112.0

※1: C(TT): Same temperature sensor as former W5 (TT).

※2: G(TT) : Same temperature sensor as former W (TT).

- Temperature sensors convert subject temperature to electrical signals for the temperature controller, allowing it to control output.
- SV (Setting Value) can only be set within the input range.

6.1.2 Input Type Settings

- This product supports multiple input types, making it possible for the user to choose from thermocouples, resistors, and analog voltage/current.
- Different sensors can be designated to each channel.

Ex.) CH1 input type = KCA.H, CH2 input type = JIC.H

Group	Parameter	Setting range	Factory default	Unit
Initial Setting Group	Input Type	See 6-1-1	K(CA).H	-



Note

- When input types are modified, the high-limit and low-limit setting values of SV are automatically changed to max/min values of operational temperature range of the modified input type. You must reset these values. (SV, Multi SV No, SV-0 to SV-3 and input bias are initialized.) However, measurement units remain the same.
- If the measured value is out of the input range, the loader program displays HHHH (high-limit), LLLL (low-limit) and displays OPEN when the sensor is not connected.

6.1.3 Temperature Unit Settings for Input Temperature Sensor

When selecting the temperature sensor input options, you can set the desired units of operation temperature/display temperature.

Group	Parameter	Range	Factory Default	Unit
Initial Setting Group	Unit	°C, °F	°C	-



Note

When modifying the temperature units, setting values of the related parameters remain the same as the existing values, and SV, Multi SV No., SV-0 to SV-3, SV high-limit/low-limit, and input bias will be initialized.

6.1.4 Input Bias Settings

- This feature is used to compensate for input bias produced by thermocouples, RTDs, or analog input devices, but NOT by the controller itself.
- The input bias adjustments function is mainly used when the sensor cannot be attached directly to control object. It is also used to compensate for temperature variance between the sensor's installation point and the actual measuring point.

Group	Parameter	Range	Factory Default	Unit
Initial Setting Group	Input Bias	-999 to 999 (H) -999.9 to 999.9 (L)	0	Digit

 Ex.	If the controller displays 78°C when the actual temperature is 80 °C, set the input bias to 2 in order to adjust the controller's display temperature to 80°C.
--	--

 Note	<ul style="list-style-type: none"> • Make sure that an accurate temperature variance measurement is taken before setting values of Input Bias. An inaccurate initial measurement can lead to greater variance. • Many of today's temperature sensors are graded by their sensitivity. Since higher accuracy usually comes at a higher cost, most people tend to choose sensors with medium sensitivity. Measuring each sensor's sensitivity bias and using the Input Bias feature for correction can ensure higher accuracy in temperature reading.
---	---

6.1.5 Input Digital Filter

It is not possible to perform high accuracy control if the PV (Present Value) fluctuates because of noise elements, disturbance, or instabilities in the input signal. Using the Input Digital Filter function can stabilize PV to realize more reliable control.

Group	Parameter	Range	Factory Default	Unit
Initial Setting Group	Input Digital Filter	0.1~ 120.0	0.1	Sec.

 Ex.	When the Input Digital Filter is set to 0.4 seconds, the digital filter is applied according to a sampling value collected over 0.4 seconds (400 ms).
--	---

 Note	When the Input Digital Filter is used, PV (Present Value) can vary from the actual input value.
---	---

6.1.6 SV High/Low-limit Settings

You can limit the SV (Setting Value) range within the temperature range of the sensor or analog input type in order to prevent the system from controlling with improper SV.

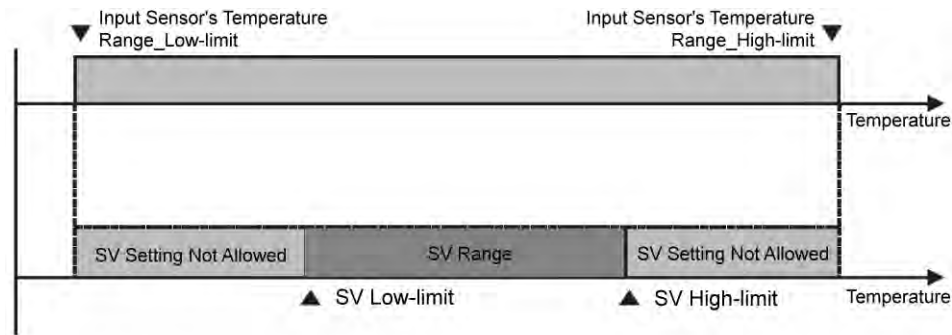

Group	Parameter	Range	Factory Default	Unit
Initial Setting Group	SV High-limit	See below.	1350	°C/°F
	SV Low-limit		-200	

- SV Low-limit : Low-limit sensor value to SV high-limit - 1 digit
- SV High-limit : SV low-limit + 1 digit to high-limit sensor value

 Note	<ul style="list-style-type: none"> • Attempts to set the limits outside the min/max input range, or analog's high/low-limits, are not accepted. Instead, the previous settings are retained. • SV (Setting Value) can only be set within the SV low-limit and SV high-limit. • SV low-limit cannot exceed SV high-limit. • Changing the input sensors automatically changes the SV high/low-limit settings to max/min values of the changed specification (temperature sensor input), or to high/low-limit scale values (analog input). The user is required to reset related settings.
---	---

6.2 Control Output

6.2.1 Control Output Operation Mode Settings

- Control output modes for general temperature control include heating, cooling, and heating and cooling.
- Heating control and cooling control are mutually opposing operations with inverse outputs.
- The PID time constant varies based on the controlled objects during PID control.

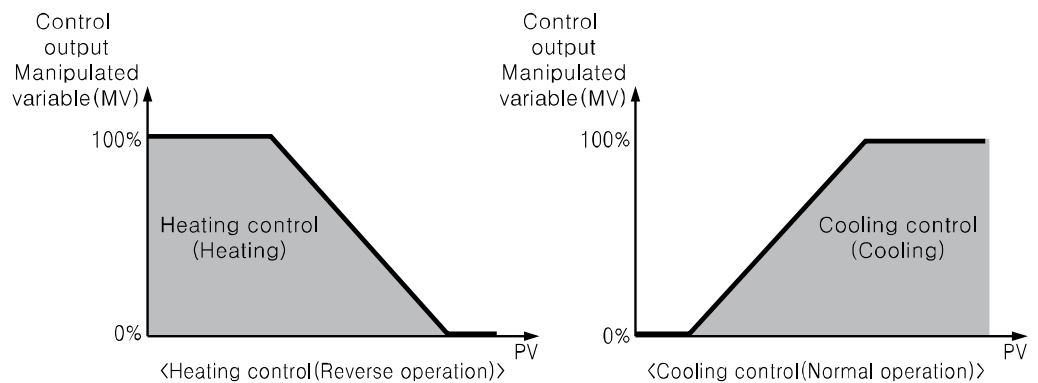

Group	Parameter	Range	Factory Default	Unit
Initial Setting Group	Operating Type	Heating, Cooling Heating and Cooling	Heating	-

6.2.1.1 Heating Control

Heating control mode: the output will be provided in order to supply power to the load (heater) if PV (Present Value) falls below SV (Setting Value).

6.2.1.2 Cooling Control

Cooling control mode: the output will be provided in order to supply power to the load (cooler) if PV (Present Value) rises above SV (Setting Value).

6.2.1.3 Heating and Cooling Control

- Heating and cooling control mode: heating and cooling with a single temperature controller when it is difficult to control subject temperature with only heating or cooling.
- Heating and cooling control mode controls the object using different PID time constants for each heating and cooling. It is also possible to set heating and cooling control in both PID control or ON/OFF control mode. Heating/cooling output can be selected among Relay output, SSR drive voltage output and current output depending on model types chosen according to your application environment. (Note that only standard SSR control is available for SSR drive output in OUT2.)

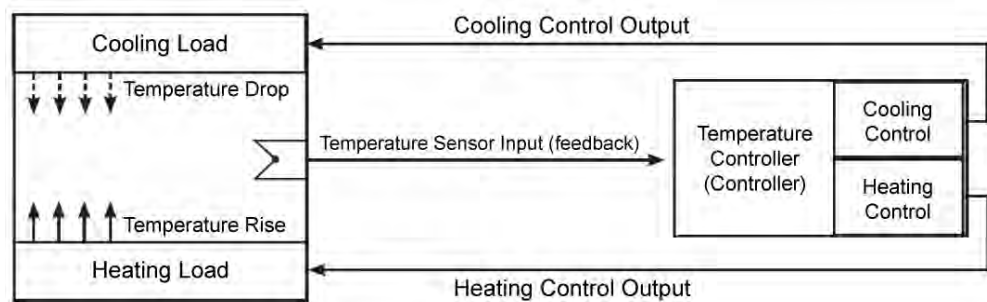

- For heating/cooling control, each output for heating and cooling is automatically allocated as described in the following table.

	Heating Control	Cooling Control	Remarks
TM4 Series	CH1 OUT	CH2 OUT	Heating output: Control output selection by model is available.
	CH3 OUT	CH4 OUT	Cooling output: Control output selection by model is available.
TM2 Series	CH1 OUT	AL1 OUT	Heating output: Control output selection by model is available.
	CH2 OUT	AL2 OUT	Cooling output: Relay output fixed

 **Note** For TM2 Series, heating output can be selected by models from relay output, SSR output and current output. Cooling output is fixed to relay output.

6.2.1.3.1. Deadband/Overlap Band

- In heating and cooling control, it is possible to designate a deadband between heating and cooling control bands based on SV (Setting Value).
- A deadband forms around the SV when DB is set to a positive value. No control occurs in the deadband area. Therefore, heating and cooling MVs become 0.0% in the formed deadband.
- An overlap band (simultaneous application of heating and cooling MVs) forms around the SV when DB is set to a negative value.

Group	Preceding Condition	Parameter	Range	Factory Default	Unit
Control Operation Group	PID-PID PID-ON/OFF ON/OFF-PID	Dead-Overlap Band	-Proportional Band to +Proportional Band	0.0	Digit
	ON/OFF-ON/OFF		-999 ~ 0 ~ 999	0	

- Set deadband to 0 when a deadband or an overlap band is not used.

 Note	<ul style="list-style-type: none"> ▪ If input display value is a decimal it is displayed as –999.9 to 999.9 ▪ When proportional bands are different, the smaller one takes precedence. ▪ Input sensor type (input.H, input.L) determines the use of a decimal point.
---	---

6.2.1.3.1.1. Using a Deadband

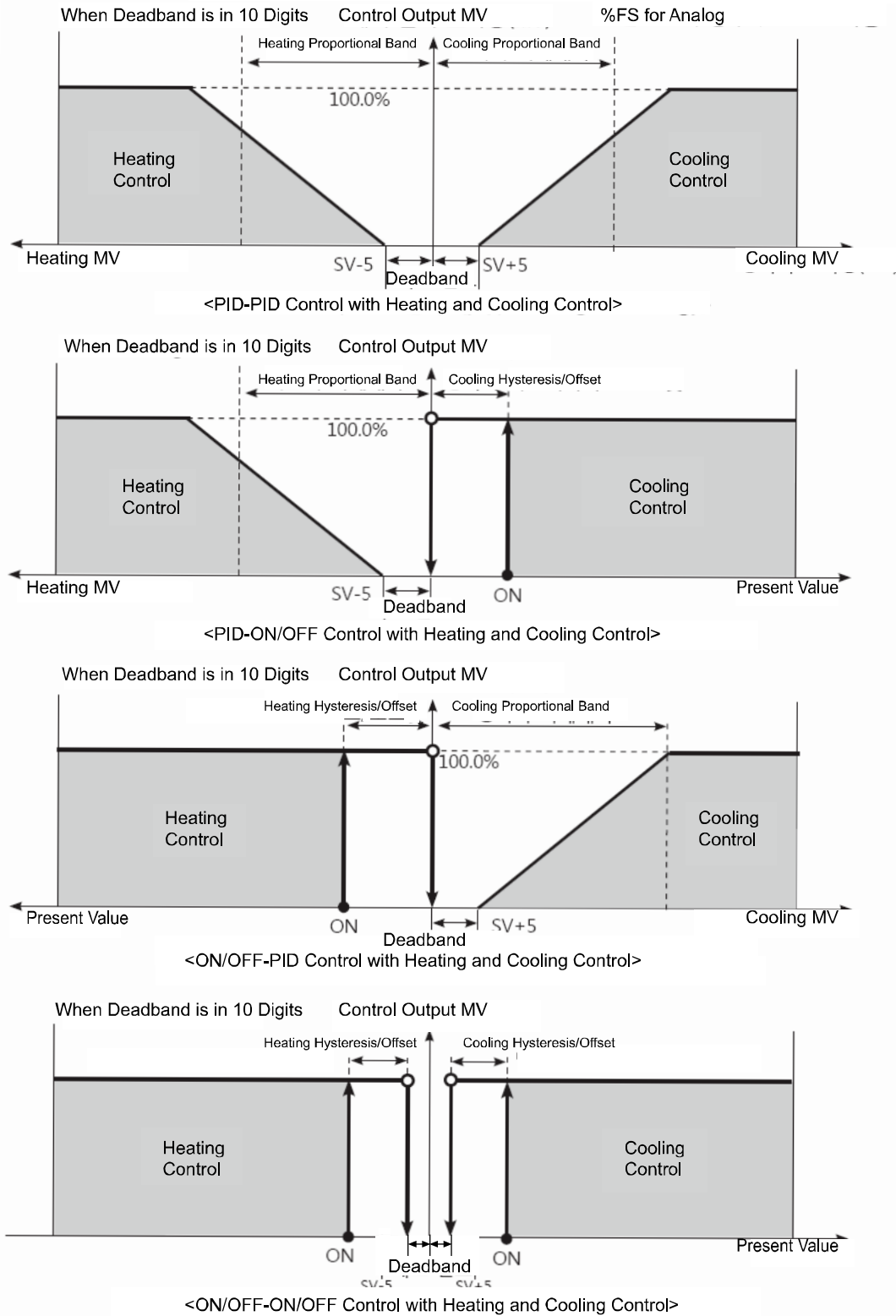

6.2.1.3.1.2. Using an Overlap Band

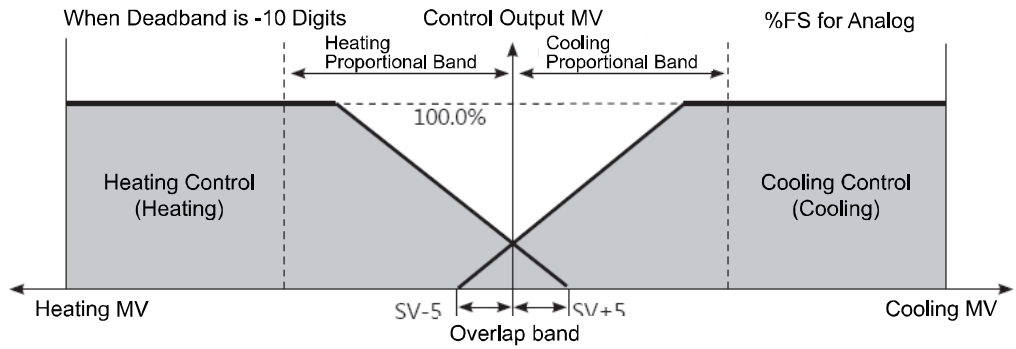

<PID-PID Control with Heating and Cooling Control>

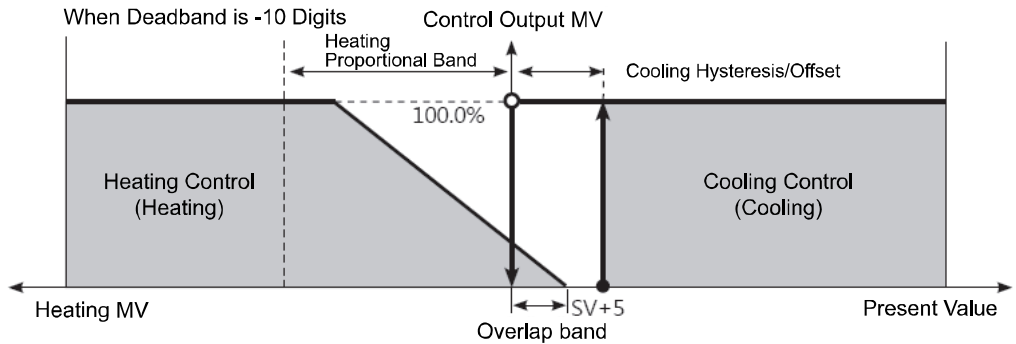

<PID-ON/OFF Control with Heating and Cooling Control>

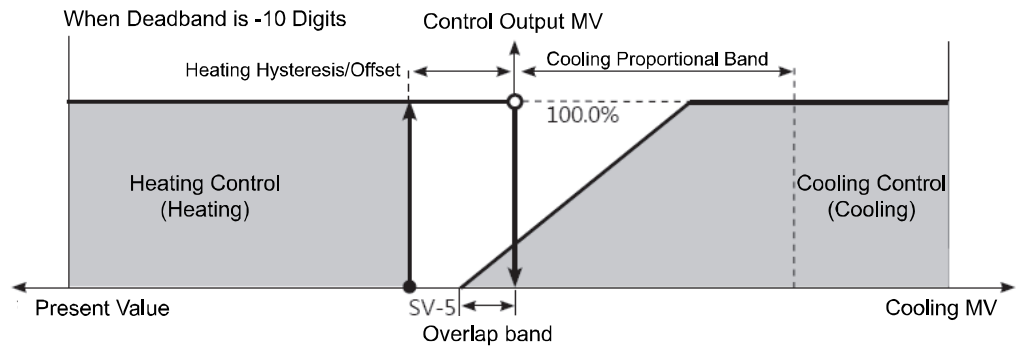

<ON/OFF-PID Control with Heating and Cooling Control>

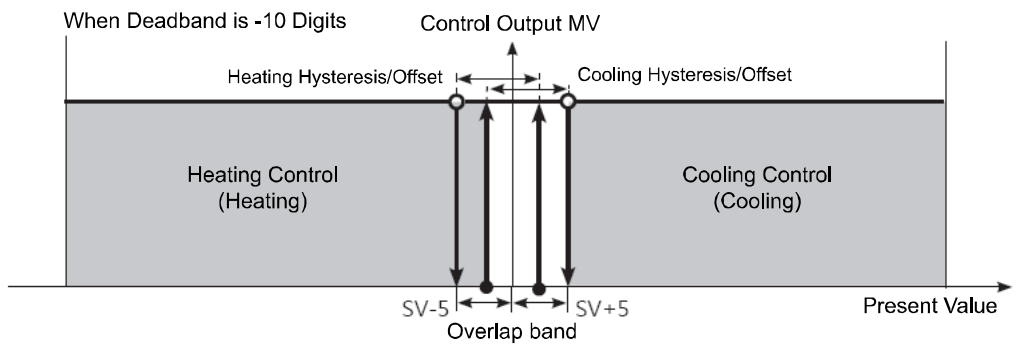

<ON/OFF-ON/OFF Control with Heating and Cooling Control>

6.2.1.3.1.3. Using neither a Deadband nor an Overlap Band

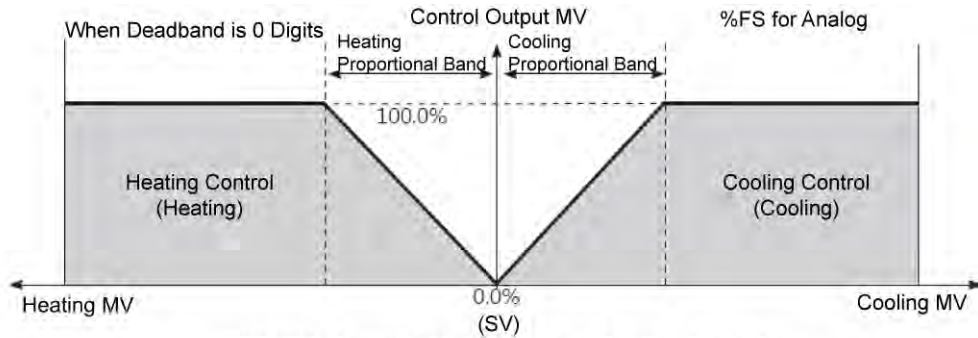

<PID-PID Control with Heating and Cooling Control>

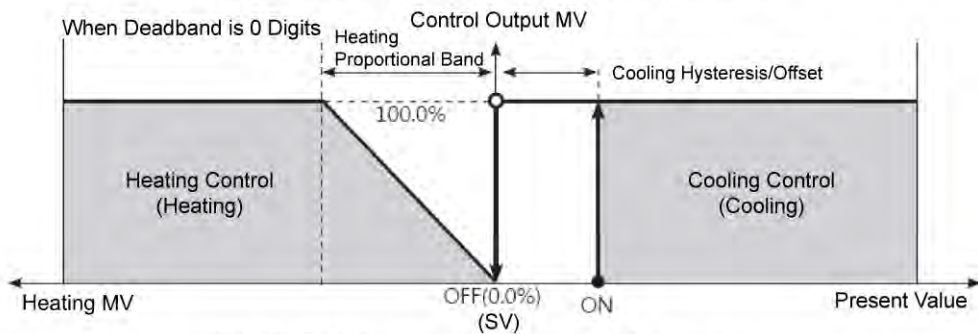

<PID-ON/OFF Control with Heating and Cooling Control>

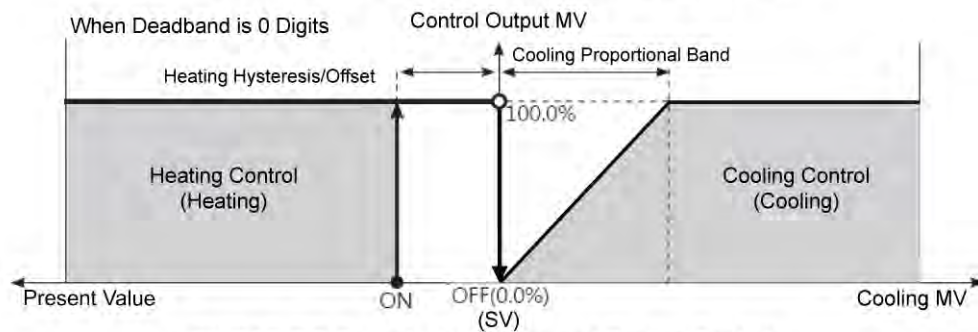

<ON/OFF-PID Control with Heating and Cooling Control>

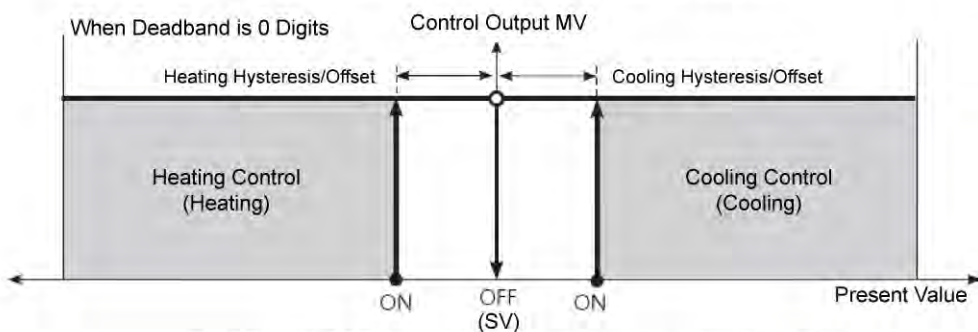

<ON/OFF-ON/OFF Control with Heating and Cooling Control>

6.2.2 MV High/Low-limit Settings

- MV high/low-limit values for control output can be configured to the actual MV, provided the temperature controller's MV calculation exceeds the limits.
- During heating and cooling control, cooling MV carries a "-" prefix. Therefore, the high-limit is expressed as a + value on the heating side and the lower limit as a - value on the cooling side.

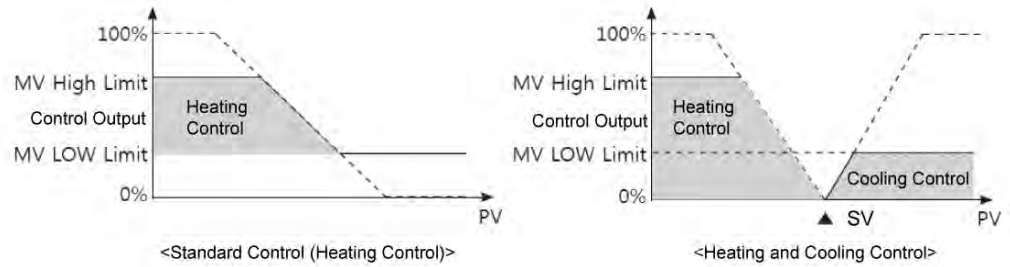

Group	Preceding Condition	Parameter	Range	Factory Default	Unit
Control Operation Group	Heating Cooling	MV Low-limit	0.0 to (MV High-limit - 0.1)	0.0	%
		MV High-limit	(MV Low-limit + 0.1) to 100.0	100.0	
	Heating and Cooling	MV Low-limit	-100.0 ~ 0.0	-100.0	%
		MV High-limit	0.0 ~ 100.0	100.0	

 Note	<ul style="list-style-type: none"> • Same MV will be applied during Auto-tuning. • MV limits are not applied to manual control, MV upon control stop, MV upon a sensor error, and initial manual control MV. • MV high/low-limit configuration is not available for ON/OFF control in standard control mode (heating or cooling control).
---	--

6.2.3 Ramp Settings

- Ramp is a feature used to configure the slope toward SV (Setting Value). The feature limits change rate of SV and thereby restricts sudden temperature changes (increase and decrease) in the control subject.
- Ramp is commonly used in applications where rapid temperature changes (increase and decrease) could impact negatively on the control subject.

Group	Parameter	Range	Factory Default	Unit
Control Operation Group	Ramp_Up[Down] Change Rate	0 (OFF) to 9999	0	Digit
	Ramp Time Unit	SEC (seconds), MIN (minutes), HOUR (hours)	MIN (minute)	-

 Ex.	For ceramic or pottery furnaces, rapid heating may break the furnace subject. Apply Ramp Up Change Rate to control the temperature.
--	---

 Note	<ul style="list-style-type: none"> • Activating the ramp feature when the ramp is not in operation limits the rate of SV (Setting Value) change based on PV (Present Value). Changing SV or ramp parameters when the ramp is in operation limits the rate of SV change based on SV at the point of the change. • SV determines the control of the control subject temperature. The SV changes based on the configured rate of change (hereinafter referred to as RAMP SV). • Ramp Up change rate and Ramp Down change rate can be set independently. • Alarm activation with the ramp in operation depends on the final SV. • Setting the rate of ramp change to 0 deactivates the ramp feature.
---	---

Ramp Status by Modes

Operation Status	RAMP RATE	Ramp Function
All modes.	When 0	Inactive
OPEN, HHHH, LLLL, Auto-tuning, Auto→Manual, RUN→STOP	Irrespective of conditions.	Inactive
OPEN, HHHH, LLLL, after Auto-tuning, PV = SV	Irrespective of conditions.	Inactive
Power On, SV change, switch from STOP to RUN, switch from Manual to Auto, Ramp Rate or Ramp time unit change	When not 0	Active

Example Ramp Graph

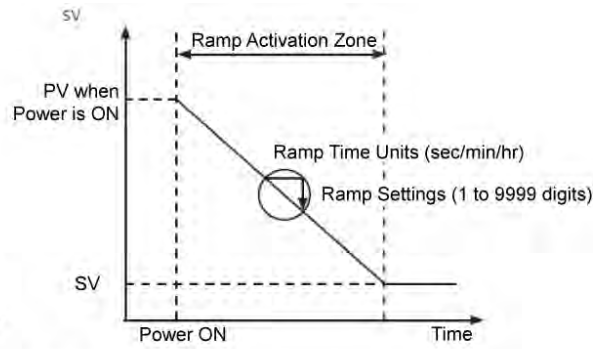
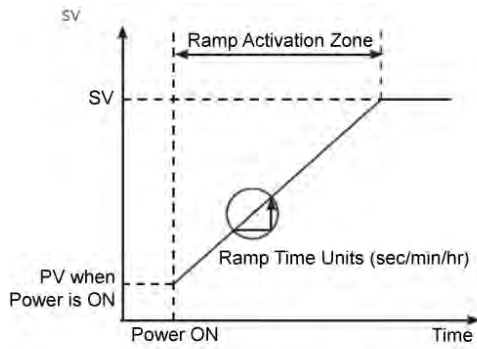

<Initial power on, Ramp value change>

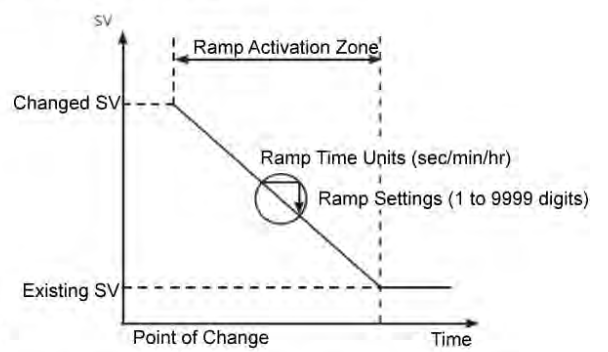
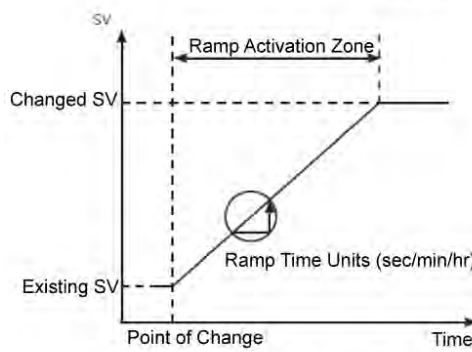

<SV setting change, Change SV setting with multi SV feature>

6.2.4 Auto/Manual Control Settings

- Auto control
: This mode implements control over MV, which is calculated under PID control and based on SV as the target.
- Manual control
: This mode implements control with user-defined MV.

Group	Parameter	Range	Factory Default	Unit
Monitoring Group	Auto-Manual Control	AUTO, MANUAL	AUTO	-

- Can be used by setting digital input terminal (DI1, DI2) to STOP function.

 Note	<ul style="list-style-type: none"> • Auto/manual control switching is not allowed in ON/OFF control mode. • When the unit is powered on following a power interruption or shutdown, auto or manual control will be maintained. • When in operation, AT (Auto-tuning) can be switched to manual control. • When in Stop mode, manual control can be activated. • If an SBA (Sensor Break Alarm) occurred during standard control, the sensor error MV (Er.MV) is applied. In this state, switching to manual mode is possible and manual control MV settings can also be modified. • When the control unit is in operation, it is possible to switch to manual or auto control mode. • Priority: Manual control > Stop > Open (sensor disconnection)
---	--

6.2.4.1 Manual Control Baseline MV.

- When switching from auto to manual control you can set the initial MV.
- AUTO-MV: When switching modes use auto control MV as the initial manual control.
- PRESET-MV: Apply preset MV as the initial MV.

Group	Preceding Condition	Parameter	Range	Factory Default	Unit
Control Setting Group	PID	Initial Manual MV	AUTO-MV: PRESET-MV:	AUTO-MV:	-

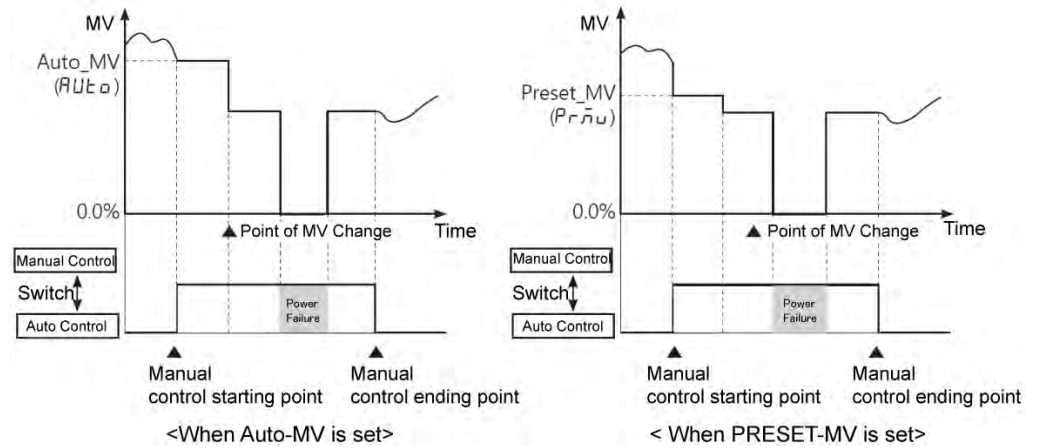

※Reverting to power, the control starts with the MV of the power off.

6.2.4.2 Manual control initial MV.

If the baseline MV for manual control is configured to PR.MV (Preset Manual MV), you can set the initial MV for manual control.

Group	Preceding Condition	Parameter	Range	Factory Default	Unit
Control Setting Group	Heating, Cooling, PID	Preset MV	0.0 ~ 100.0	0.0	%
	Heating and Cooling, PID		-100.0 (Cool) to 0.0 to 100.0 (Heat)	0.0	

Note When in heating and cooling control, a setting between 0.1 and 100.0 applies heating MV, and a setting between 0.1 and -100.0 applies cooling MV.

6.2.5 Output Settings

6.2.5.1 Control Output Settings

If the control output type is a current or SSR output model, control output is supported at the same time, so the user can choose a suitable output type.

Group	Parameter	Range	Factory Default	Unit
Initial Setting Group	Output Type	Current, SSR	SSR	-

Note The relevant parameter will be activated only if the model is TM2-□□C□ (current or SSR output type).

6.2.5.2 Current Output Range Settings

If the control output is set to current output, you can select high and low-limit range for the current output as either 4-20mA or 0-20mA.

Group	Parameter	Range	Factory Default	Unit
Initial Setting Group	Current Output Range	0-20, 4-20	4-20	-

**Note**

If the model is TM2-□□C□ (current or SSR output type), the relevant parameter will be activated only if the control output is set to current.

6.3 Temperature Control

6.3.1 Temperature Control Method Settings

You can choose the type of temperature control method.

Group	Preceding Condition	Parameter	Range	Factory Default	Unit
Initial Setting Group	Heating, Cooling	Control Method	PID, ONOFF	PID	-
	Heating and Cooling		PID-PID PID-ON/OFF ON/OFF-PID ON/OFF-ON/OFF	PID-PID	-

6.3.2 ON/OFF Control

Controls the temperature by comparing PV(Present Value) with SV(Setting Value) and turning power to the load on or off.

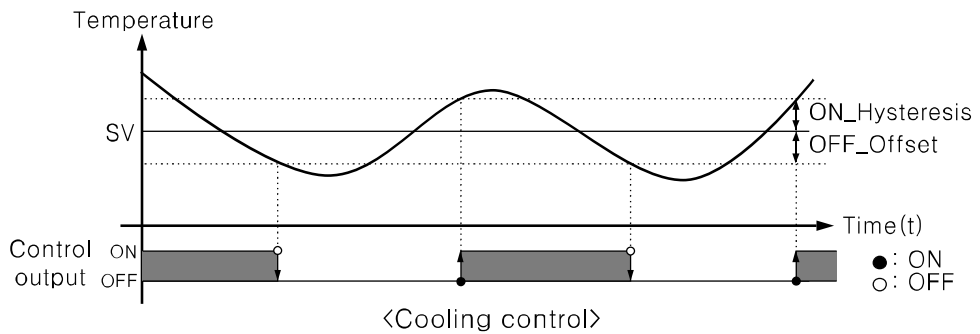
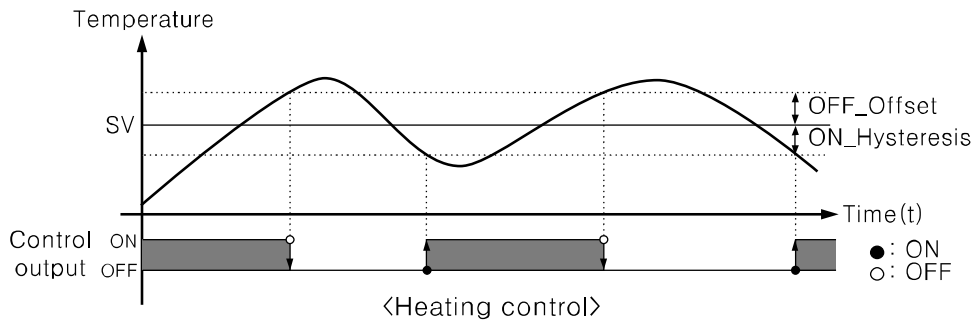

6.3.2.1 Hysteresis Settings

- An ON/OFF control feature is used to define the control output ON/OFF points. ON_Hysteresis sets the output on point and OFF_Offset sets the off point.
- Setting hysteresis too low can result in hunting induced by disturbance (noise, chattering, etc.). To minimize hunting, set ON_Hysteresis and OFF_Offset values according to the heater or cooler's capacity and thermal characteristics, control subject and sensor response characteristics, installation conditions, and other defining factors.

Group	Preceding Condition		Parameter	Range	Factory Default
Control Operation Group	Heating and Cooling	Heating	Heating_ON Hysteresis	1~100	2
			Heating_OFF Offset	0~100	0
	Cooling	Cooling_ON Hysteresis	1~100	2	
		Cooling_OFF Offset	0~100	0	

6.3.3 PID Control

- PID control is a combination of proportional (P), integral (I), and derivative (D) controls and offers superb control over control subjects, even with a delay time.
- Proportional control (P) implements smooth, hunting-free control; integral control (I) automatically corrects offsets; and derivative control (D) speeds up the response to disturbance. Through these actions, PID control realizes ideal temperature control.

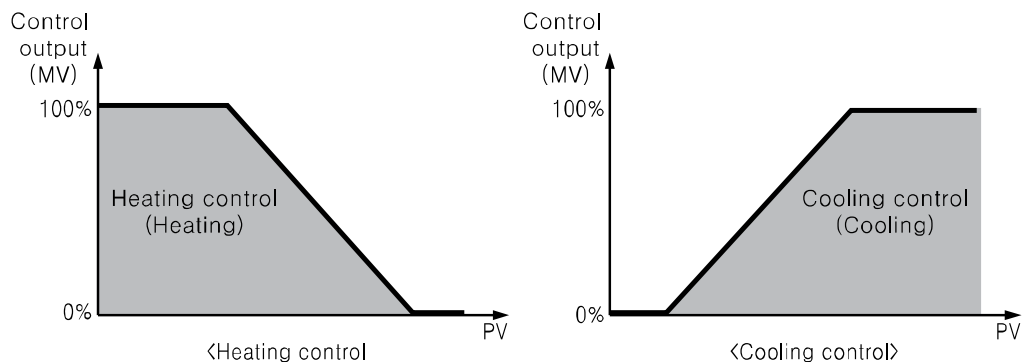

 <p>Note</p>	<p>How to apply PID control</p> <ul style="list-style-type: none"> • Proportional (P) control: Set both integral and derivative times to 0 after PID control is selected. • Proportional-Integral (PI) control: Set the derivative time to 0 after PID control is selected. • Proportional-Derivative (PD) control: Set the integral time to 0 after PID control is selected. • When using the multi-SV function, the same PID time constant will be applied to SV0 to SV3.
--	--

6.3.3.1 Proportional Band Settings

When PV (Present Value) is within the proportional band (P), the ON/OFF ratio needs to be adjusted during the proportional period (T). The defined proportional control (time proportional control) section is referred to as the proportional band.

Group	Preceding Condition	Parameter	Range	Factory Default	Unit
Control Operation Group	Heating, PID	Heating_Proportional Band	0.1 ~ 999.9	10.0	℃
	Cooling, PID	Cooling_Proportional Band			

6.3.3.2 Integral Time Settings

MVs from integral and proportional operation become the same when deviation is consistent. The time taken for the two MVs to match is called the integral time.

Group	Preceding Condition	Parameter	Range	Factory Default	Unit
Control Operation Group	Heating, PID	Heating_Integral Time	0 ~ 9999	0	Sec.
	Cooling, PID	Cooling_Integral Time			



Note

- Integral control is not conducted if the integral time is set to 0.
- Setting the integral time too short can intensify Correction Movements and cause hunting.

6.3.3.3 Derivative Time Settings

In accordance with the deviation of the ramp, the time taken for the MV gained from derivative operation to reach the MV gained from proportional control is called the derivative time.

Group	Preceding Condition	Parameter	Range	Factory Default	Unit
Control Operation Group	Heating, PID	Heating_Derivation Time	0 ~ 9999	0	Sec.
	Cooling, PID	Cooling_Derivation Time			



Note

Derivative control is not conducted if the derivative time is set to 0.

6.3.3.4 Control Period Settings

- If relay or SSR is used to send out MV under proportional control, the output is on for a fixed amount of time (within the control period, as a percentage of the MV) and then remains off. The preset period when output ON/OFF takes place is called the proportional control period.
- Control using SSR drive voltage output has a faster response than that of relay output. Therefore, by configuring a shorter control period, more responsive temperature control is achieved.

Group	Preceding Condition	Parameter	Range	Factory Default	Unit
Initial Setting Group	Heating, PID	Heating_ Control Time	0.1 ~ 120.0	20.0 (RELAY) 2.0 (SSR)	Sec.
	Cooling, PID	Cooling_ Control Time			

	Note	If using heating and cooling control, configure each control period separately for heating and cooling.
---	-------------	---

6.3.3.5 Offset Correction/Manual Reset Settings

When only proportional control (P, PD control) is used, the control subject's thermal capacity and heater capacity affect the heating and cooling time. This means stable control will still experience some deviation called offset. Offset can be corrected using manual reset.

Group	Preceding Condition	Parameter	Range	Factory Default	Unit
Control Operation Group	PID	Manual Reset	0.0 ~ 100.0	50.0	%

Manual Reset Adjustment based on Control Results

Under stable control conditions, set the offset to 50% if PV and SV are identical, to over 50.0% if PV is lower than SV, and below 50.0% if PV is higher than SV.

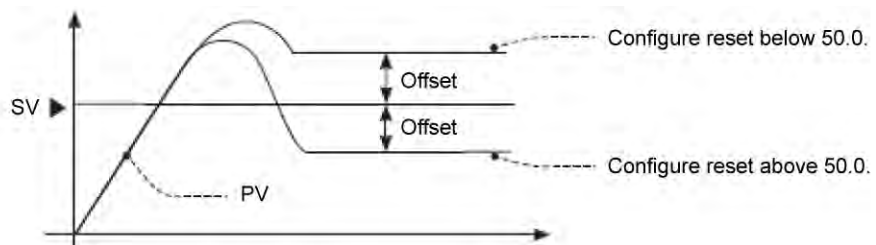

	Note	<ul style="list-style-type: none"> • The offset correction feature can only be used when proportional control is in effect. Setting the integral value to 0 makes the manual reset parameter visible. • The user cannot configure the manual reset setting during heating and cooling control. Instead, the setting is automatically set to 0% for both heating and cooling.
---	-------------	--

	<ul style="list-style-type: none"> • Applicable only when integral time is set to 0 (under P control or PD control only). • Switching from heating and cooling control to standard control (P, PD control) automatically configures the reset setting to 50%.
--	---

6.3.4 Auto-tuning

In PID control, auto-tuning processes the control subject's thermal characteristics and thermal response rate, and then determines the necessary PID time constant. Application of the PID time constant realizes fast response and high precision temperature control.

6.3.4.1 Auto-tuning ON/OFF Settings

- Auto-tuning automatically stores PID time constants upon termination. These PID time constants can then be modified by the user to suit their usage environment.
- When performing auto-tuning, the output LED of the pertinent channel flashes at 1 second intervals. Once auto-tuning is complete, the output LED automatically goes off, and the parameter value returns from ON to OFF.

Group	Preceding Condition	Parameter	Range	Factory Default	Unit
Control Operation Group	PID	Auto-tuning Execute	OFF/ON	OFF	-

 Note	<ul style="list-style-type: none"> • If manual control is selected during auto-tuning, auto-tuning operation will be closed. • If a sensor disconnection error occurred during auto-tuning, the sensor is automatically closed and the previous PID time constant kept. • Auto-tuning continues to run even if the temperature reading exceeds or falls below the input range. • When auto-tuning is in progress, parameters can only be referenced and not altered. • When auto-tuning is in progress and digital input(DI-1,DI-2) feature is run/stop or auto/manual, auto-tuning will be automatically ended, if concerned DI is inputted or a sensor disconnection error occurs. • Auto-tuning is not available in manual control.
---	--

6.3.4.2 Auto-tuning Mode Settings

- Auto-tuning is available in Tun1 MODE (SV) or Tun2 MODE (70% of SV), depending on the baseline value used.
- Tun1 Mode [TUN1]: Auto-tunes and calculates a PID time constant based on SV.
- Tun2 Mode [TUN2]: Auto-tunes and calculates a PID time constant based on 70% of SV.

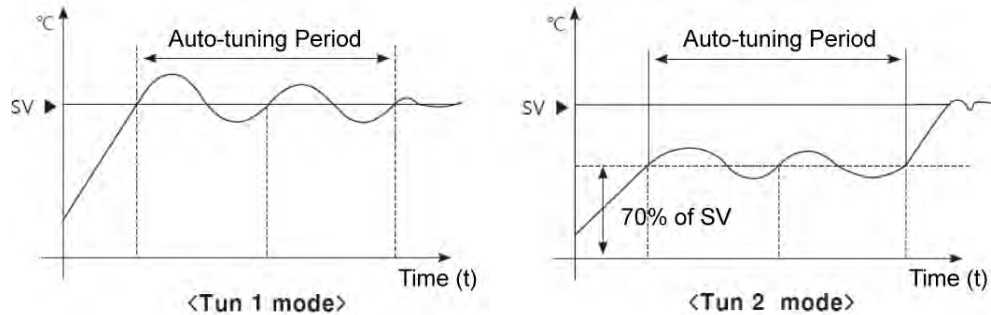

Group	Preceding Condition	Parameter	Range	Factory Default	Unit
Initial Setting Group	PID	Auto-tuning Mode	Tun1 Tun2	Tun1	-



Note

In cooling control mode, TUN2 Mode calculates 70% based at 0°.
 • EX) If SV is -100, executes TUN2 at -70.

6.4 Alarm Output

- Alarm output is a relay output that activates irrespective of control output.
- Alarm output works when the temperature of the controlled subject exceeds or falls below the preset temperature range.
- Alarm temperature setting values consist of absolute temperatures or offset temperatures, depending on the alarm output mode.
- Alarm output function is only for TM2 series.

6.4.1 Alarm Output Target Channel Settings

Users can set channels in which alarm output (2EA or 4EA) will be activated.

Group	Parameter	Range	Factory Default	Unit
Alarm Setting Group	Alarm Target Ch	CH1, CH2, CH1 and CH2, CH1 or CH2	Alarm 1, 3 : CH1 Alarm 2, 4 : CH2	-

 Note	In case of heating/cooling control, Alarm 1 and Alarm 2 are used as a cooling control output; therefore, they cannot be used as an alarm output.
---	--

6.4.2 Alarm Output Operating Mode Settings

Select the desired alarm output mode.

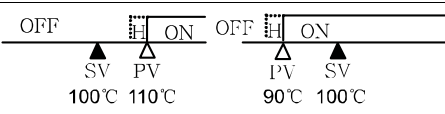
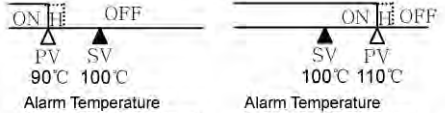
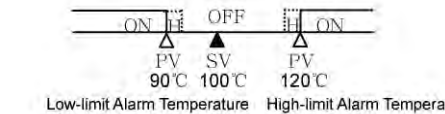
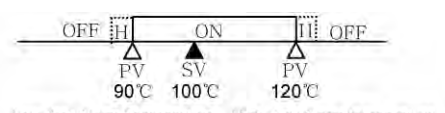
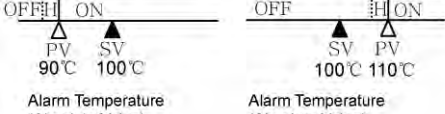
Mode	Alarm Output	Description (Factory Default)
OFF	—————	Alarm off
AL-1	 <p>Alarm Temperature (Deviation Temperature) : Set to 10°C</p> <p>Alarm Temperature (Deviation Temperature) : Set to -10°C</p>	Deviation High-limit Alarm (+FS) <ul style="list-style-type: none"> If PV/SV deviation occurs higher than set value of deviation temperature, alarm output will be ON. High limit deviation temperature can be set in AL1.H/AL2.H/AL3.H/AL4.H.
AL-2	 <p>Alarm Temperature (Deviation (Temperature)) : Set to 10°C</p> <p>Alarm Temperature (Deviation (Temperature)) : Set to -10°C</p>	Deviation Low-limit Alarm (+FS) <ul style="list-style-type: none"> If PV/SV deviation occurs lower than set value of deviation temperature, alarm output will be ON. Low-limit deviation can be set in AL1.H/AL2.H/AL3.H/AL4.H.
AL-3	 <p>Low-limit Alarm Temperature (Deviation Temperature) : 10°C</p> <p>High-limit Alarm Temperature (Offset Temperature) : Set to 20°C</p>	Deviation High/Low-limit Alarm (+FS) <ul style="list-style-type: none"> If PV/SV deviation occurs higher than high-limit deviation or lower than low-limit deviation, alarm output will be ON. High-limit deviation can be set in AL1.H/AL2.H/AL3.H/AL4.H. Low-limit deviation can be set in AL1.H/AL2.H/AL3.H/AL4.H.
AL-4	 <p>Low-limit Alarm Temperature (Deviation Temperature) : 10°C</p> <p>High-limit Alarm temperature (Offset Temperature) : Set to 20°C</p>	Deviation High/Low-limit Reverse Alarm <ul style="list-style-type: none"> If PV/SV deviation occurs higher than low-limit deviation or lower than high-limit deviation, alarm output will be ON High-limit deviation can be set in AL1.H/AL2.H/AL3.H/AL4.H. Low-limit deviation can be set in AL1.H/AL2.H/AL3.H/AL4.H.
AL-5	 <p>Alarm Temperature (Absolute Value) : Set to 90°C</p> <p>Alarm Temperature (Absolute Value) : Set to 110°C</p>	Absolute Value High-limit Alarm <ul style="list-style-type: none"> If PV is higher than the absolute value of temperature, alarm output will be ON. Alarm absolute value can be set in AL1.H/AL2.H/AL3.H/AL4.H.

Mode	Alarm Output	Description (Factory Default)
AL-6	<p>Alarm Temperature (Absolute Value) Set to 90°C</p> <p>Alarm Temperature (Absolute Value) Set to 110°C</p>	Absolute Value Low-limit Alarm <ul style="list-style-type: none"> If PV is lower than the absolute value of temperature, alarm output will be ON. Alarm absolute value can be set in AL1.L/AL2.L/AL3.L/AL4.L.
LBA	On if loop break is detected.	Loop Break Alarm
SBA	On if sensor break is detected.	Sensor Break Alarm
HBA	On if current transformer (CT) detects heater break.	Heater Burnout Alarm

Group	Parameter	Range	Factory Default	Unit
Alarm Setting Group	Alarm Mode	See above table.	Alarm 1, 3 : AL-1 Alarm 2, 4 : AL-2	-

6.4.3 Alarm Output Option Settings

Select the desired alarm output option mode.

Setting	Mode	Description
AL-A	Standard Alarm	If it is an alarm condition, alarm output is ON. Unless an alarm condition, alarm output is OFF.
AL-B	Alarm latch ※ ¹	If it is an alarm condition, alarm output is ON. Before reset the alarm, an ON condition is latched. (Holding the alarm output)
AL-C	Standby sequence1 ※ ²	When power is supplied and it is an alarm condition, alarm output does not act. From the second alarm conditions, standard alarm acts..
AL-D	Alarm latch and standby sequence1	When power is supplied and it is an alarm condition, alarm output does not act. From the second alarm conditions, alarm latch acts.
AL-E	Standby sequence2	When Standby sequence※ ³ and it is an alarm condition, alarm output does not act. After deactivate the alarm condition, standard alarm acts.
AL-F	Alarm latch and standby sequence2	When Standby sequence※ ³ is repeated and it is an alarm condition, alarm output does not act. After deactivate the alarm condition, alarm latch acts..

※1: Alarm Latch: Deactivating Alarm Output in Alarm Latch mode: Turn off the power or send alarm reset signal.

※2: Standby sequence: This option is applied only if PV is in alarm output ON conditions when power is supplied. If not, alarm output will be provided from the first alarm condition same as other alarm operations.

※3: Conditions of repeated Standby sequence: Power ON, Changing SV, Related Alarm(operation mode, option, setting value), Changing Parameter, Changing STOP mode to RUN mode.

Group	Parameter	Range	Factory Default	Unit
Alarm Setting Group	Alarm Type	See above table.	AL-A	-

**Note**

- You can set alarm output (Alarm 1 Type to Alarm 4 Type) individually.
- If alarm output mode has been selected as LBA, SBA or HBA, AL-C, AL-D modes are not available.

6.4.4 Alarm SV setting

You can set alarm output activation values. According to the selected alarm output mode, configuration parameters (AL□.H/AL□.L) will be activated for each setting.

Group	Parameter	Range	Factory Default	Unit
Alarm Setting Group	Alarm High_CH Alarm Low_CH	Deviation alarm: • By input type –F.S. to F.S. Absolute value alarm: • Within display range by input type	1550	℃, °F

**Note**

Changing the alarm output mode or options resets the settings to the highest or lowest values that will not trigger output in the new mode.

6.4.5 Alarm Output Hysteresis Settings

“H” shown in the image from 6-4-2. Alarm Output Mode represents the alarm output hysteresis. It is used to set an interval between alarm output ON/OFF periods.

- Can be set individually by alarm output (Alarm 1 Type to Alarm 2 Type).

Group	Parameter	Range	Factory Default	Unit
Alarm Setting Group	Alarm Hysteresis_Ch	1 to 100 (Temperature H), 0.1 to 100.0 (Temperature L)	1	℃, °F

**Note**

- Alarm output hysteresis applies to heater burnout alarm (HBA) in the same manner.
- This parameter does not appear if Loop Break Alarm (LBA) or Sensor Break Alarm (SBA) is selected.

6.4.6 Alarm Output Method Settings

- Relay type can be set at alarm output.
- N.O. (Normally Open) stays open when normal and closes in the event of an alarm.
- N.C. (Normally Closed) stays closed when normal and opens in the event of an alarm.

Front LED Indicators

Change	Alarm Occurs	Alarm Output	Front LED
N.O.	OFF	Open	<input type="checkbox"/> OFF
	ON	Close	<input checked="" type="checkbox"/> ON
N.C.	OFF	Close	<input type="checkbox"/> OFF
	ON	Open	<input checked="" type="checkbox"/> ON

Group	Parameter	Range	Factory Default	Unit
Alarm Setting Group	Alarm NO/NC	NO, NC	NO	-

6.4.7 Alarm Output Delay Settings

- Alarm output delay can be set to prevent false alarms caused by erroneous input signals resulting from disturbances or noise.
- With a preset delay time, alarm output does not turn on for the preset duration. Instead, the concerned alarm indicator on the front will flash in 0.5-second intervals.
- Alarm ON delay time: Stands by for the preset duration upon an alarm event, checks the alarm trigger conditions, and turns on the alarm output if the conditions are still present.
- Alarm OFF delay time: Stands by for the preset duration following alarm output off, checks the alarm trigger conditions, and turns off the alarm output if the deactivation conditions are still present.

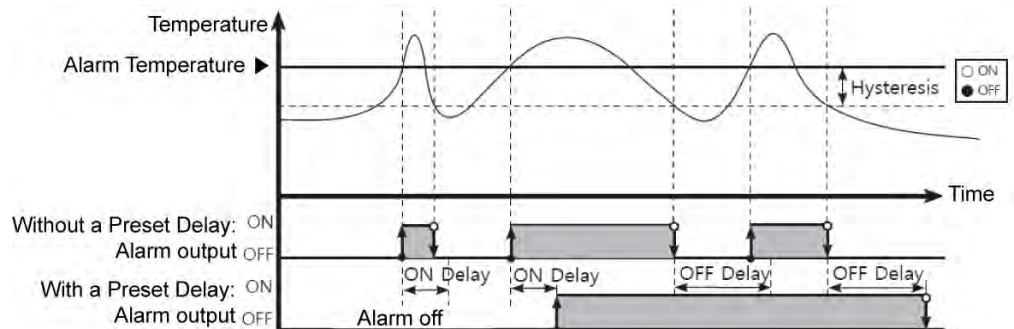

Group	Parameter	Range	Factory Default	Unit
Alarm Setting Group	Alarm ON Delay Time	0 ~ 3600	0	Sec.
	Alarm OFF Delay	0 ~ 3600	0	Sec.

6.4.8 Loop Break Alarm

- Diagnoses the control loop by monitoring the control subject's temperature changes and sends out alarms if necessary.
- Heating control: When control output MV is 100% or high limit ($H - \bar{n}\mu$) and PV is not increased over than LBA detection band ($LbA.b$) during LBA monitoring time ($LbA.t$), or when control output MV is 0% or low limit ($L - \bar{n}\mu$) and PV is not decreased below than LBA detection band ($LbA.b$) during LBA monitoring time ($LbA.t$), alarm output turns ON.
- Cooling control: When control output MV is 0% or low limit ($L - \bar{n}\mu$) and PV is not increased over than LBA detection band ($LbA.b$) during LBA monitoring time ($LbA.t$), or when control output MV is 100% or high limit ($H - \bar{n}\mu$) and PV is not decreased

below than LBA detection band (**L bA.b**) during LBA monitoring time (**L bA.t**), alarm output turns ON.

Common Causes of LBA Output On

- Sensor error (disconnection, short)
- External controller error (magnet, auxiliary relay, etc.)
- External load error (heater, cooler, etc.)
- Misconnections and disconnections of external network

 Note	<ul style="list-style-type: none"> • Set alarm output mode(AL - <input type="checkbox"/>) as loop break alarm (L bA) and you can use loop break alarm. • LBA operates only when control output MV is low limit (L - nL), 0%, high limit (H - nH), or 100%. • In case of AT (auto-tuning)/manual control/stop control, loop break alarm (L bA) does not operate <p>When alarm reset is input, it initializes LBA monitoring start time.</p>
---	--

6.4.8.1 LBA Monitoring Time Settings

You can set the loop break monitoring time to check changes in the control subject's temperature. Automatically setting with auto-tuning.

Group	Parameter	Range	Factory Default	Unit
Alarm Setting Group	LBA Time_Ch1, LBA Time_Ch2	0~9999	0	Sec.

6.4.8.2 LBA Detection Band Settings

You can set the minimum value of deviation change to decrease during LBA monitoring time. Automatically setting with auto-tuning.

Group	Parameter	Range	Factory Default	Unit
Alarm Setting Group	LBA Band_Ch1, LBA Band_Ch2	1~999 0.1~999.9	3	°C, °F

It checks control loop and outputs alarm by temperature change of the subject. For heating control(cooling control), when control output MV is 100%(0% for cooling control) and PV is not increased over than LBA detection band [L bR.b] during LBA monitoring time [L bR.t], or when control output MV is 0%(100% for cooling control) and PV is not decreased below than LBA detection band [L bR.b] during LBA monitoring time [L bR.t], alarm output turns ON.

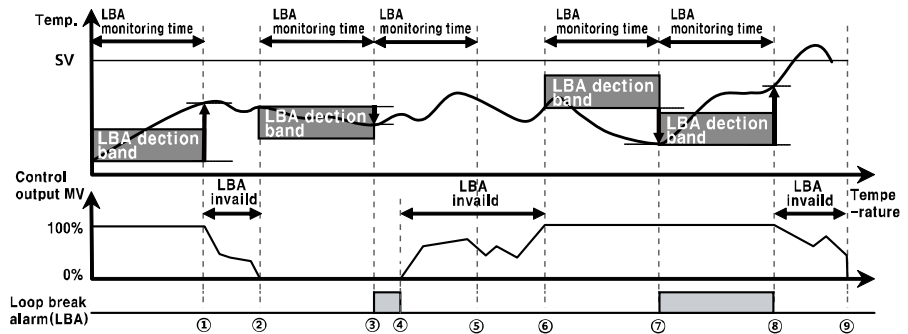

Ex.

Start to ①	When control output MV is 100%, PV is increased over than LBA detection band [L bR.b] during LBA monitoring time [L bR.t].
① to ②	The status of changing control output MV (LBA monitoring time is reset.)
② to ③	When control output MV is 0% and PV is not decreased below than LBA detection band [L bR.b] during LBA monitoring time [L bR.t], loop break alarm (LBA) turns ON after LBA monitoring time.
③ to ④	Control output MV is 0% and loop break alarm (LBA) turns and maintains ON.
④ to ⑥	The status of changing control output MV (LBA monitoring time is reset.)
⑥ to ⑦	When control output MV is 100% and PV is not increased over than LBA detection band [L bR.b] during LBA monitoring time [L bR.t], loop break alarm (LBA) turns ON after LBA monitoring time.
⑦ to ⑧	When control output MV is 100% and PV is increased over than LBA detection band [L bR.b] during LBA monitoring time [L bR.t], loop break alarm (LBA) turns OFF after LBA monitoring time.
⑧ to ⑨	The status of changing control output MV (LBA monitoring time is reset.)

When in s
alarm outp
LBA Dete
the LBA d
time (L bR

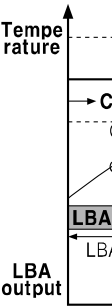

Control s
Control Sta
①
②
③
④
⑤

6.4.9 Sensor Disconnection Alarm

- You can set the controller to send out an alarm when a sensor is not connected or disconnected during temperature control.
- Sensor break can be confirmed through an external alarm output contact, such as a buzzer or similar means.
- Setting alarm output mode (alarm mode) to SBA will activate sensor break alarm.



Note

Alarm output option can be set to standard alarm (AL-A) or alarm latch (AL-B).

6.4.10 Heater Disconnection Alarm

- When using a heater to raise the temperature of the control subject, the temperature controller can be set to detect heater disconnection and send out an alarm by monitoring power supply to the heater.
- Heater disconnection is detected by the controller using a current transformer (CT), which converts the current to the heater to a specific ratio (C•Tratio) for monitoring. If the heater current value (CT-A) measured by the C•T is less than the heater detection setting value (Alarm Low_CH), the heater burnout alarm will activate.

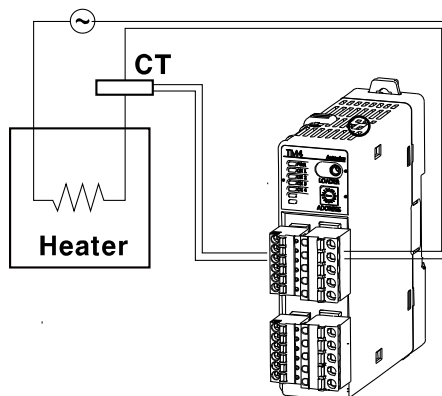

Note

- Heater burnout detection only takes place when the temperature controller's output is turned on. Otherwise, heater burnout will not be detected by the controller.
- Detection is only available in models with switching output (relay, SSR output).
- Current detection is not performed if OUT control output time is less than 250 ms.
- It is recommended to use Autonics designated current transformer (for 50 A).
- Alarm output option can be set to standard alarm (AL-A) or alarm latch (AL-B).

6.4.10.1 Heater Disconnection Detection SV

Set the alarm output value (Alarm Low_Ch) as the reference value for heater burnout detection.

Group	Parameter	Range	Factory Default	Unit
Alarm Setting Group	Alarm Low_CH	0.0 ~ 50.0	0.0	A

 Note	<p>Set to 00.0 for OFF. Set to 50.0 for ON.</p> <ul style="list-style-type: none"> Setting value calculation : Heater burnout setting value = {(normal heater current values) + (heater burnout current)}/2
---	--

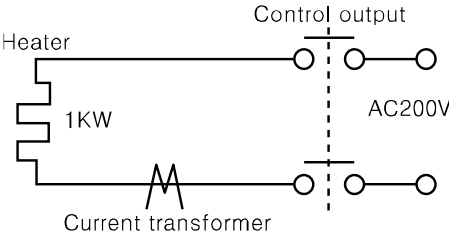
 Ex.	<p>If using a single output heater (Capacity: 200 VAC, 1 KW, 5 A), normal heater current is 5 A, and burnout heater current is 0 A, the setting value is calculated as $(5\text{ A} + 0\text{ A})/2 = 2.5\text{ A}$. Therefore, heater current values less than 2.5 A (heater burnout setting value) will be deemed heater burnout and the alarm will activate.</p> 
--	--

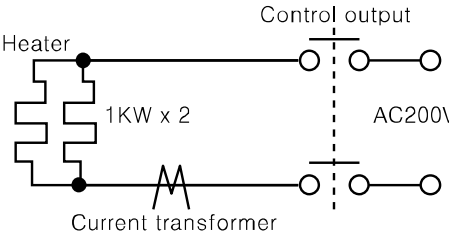
 Ex.	<p>When two output heaters (Capacity: 200 VAC, 1 KW, 5 A) are used, normal heater current is 10 A (5 A X 2 EA). If a single heater burns out, the heater current becomes 5A. The setting value is calculated as $(10\text{ A} + 5\text{ A})/2 = 7.5\text{ A}$. Heater current values of less than 7.5 A (heater burnout setting value) are deemed heater burnout and the alarm activates.</p> 
--	---

6.4.11 Alarm Output Off

- Available only if alarm output option is set to alarm latch or alarm latch and standby sequence1, alarm latch and standby sequence2. It can be set to turn off alarm output when alarm output is on, alarm output conditions have been removed, or an alarm output off signal that is greater than the minimal signal band is received. (However, alarm output off is unavailable when alarm conditions remain in effect.)
- You can assign the digital input terminals (DI-1, DI-2) for the alarm output off feature.

**Note**

- For more information about digital terminal (DI) setting, please refer to '6-6-4-1'.
- After deactivating the alarm output, it will function normally for the next alarm output occurrence.

6.4.12 Alarm Output Examples

6.4.12.1 Absolute Value High-limit Alarm and Deviation High-limit Alarm

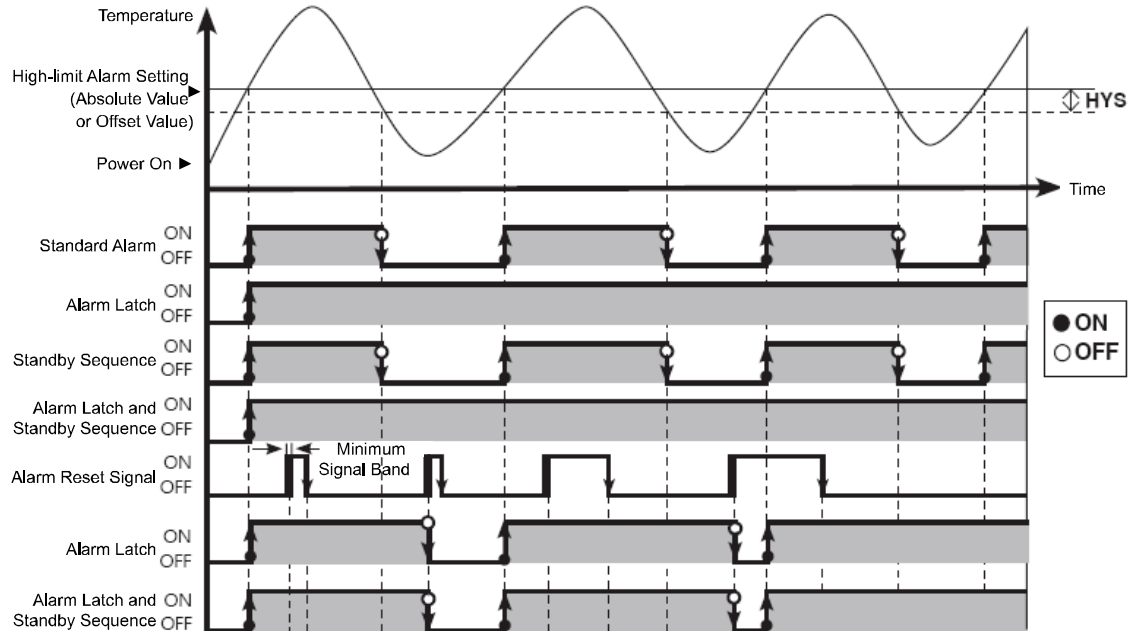

6.4.12.2 Absolute Value Low-limit Alarm and Deviation Low-limit Alarm

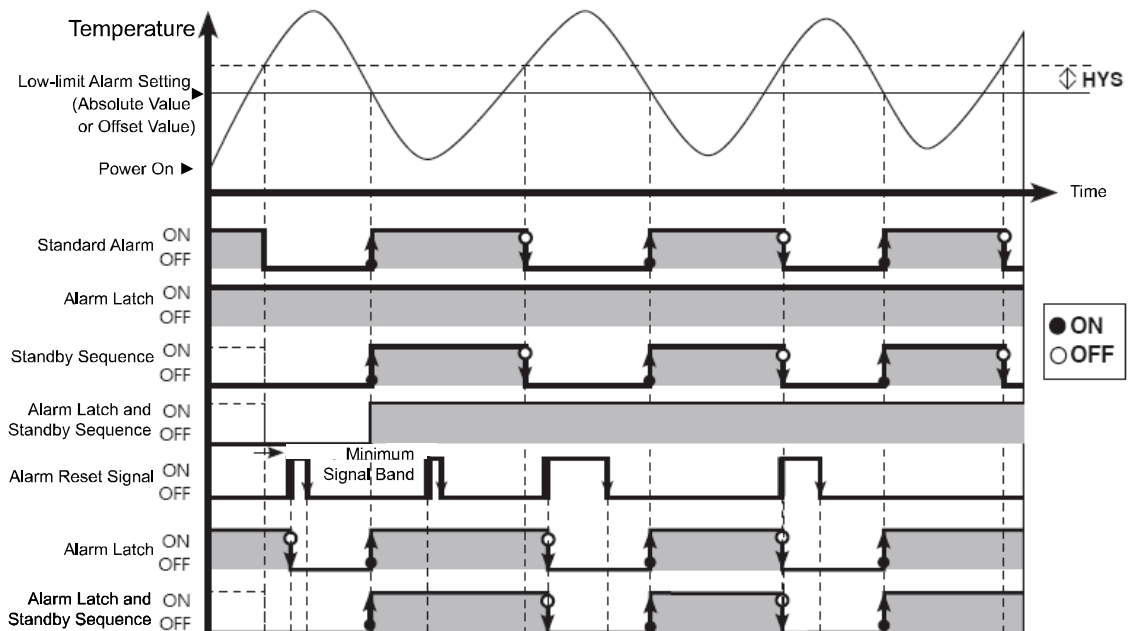

6.4.12.3 Deviation High/Low-limit Alarm

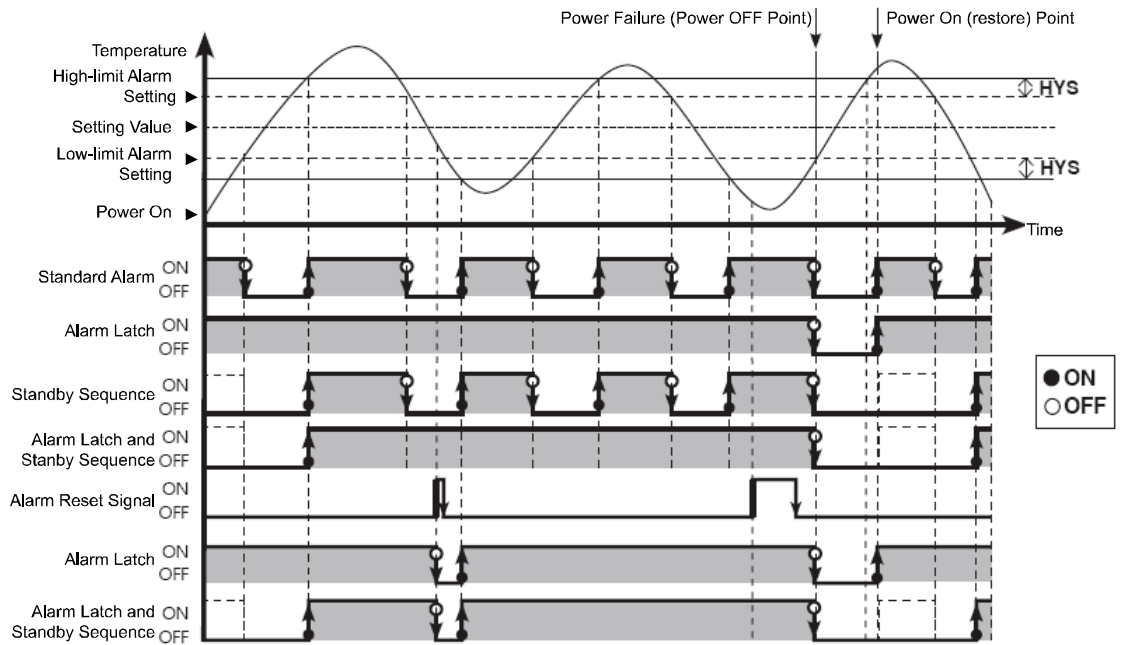

6.4.12.4 Deviation High/Low-limit Reverse Alarm

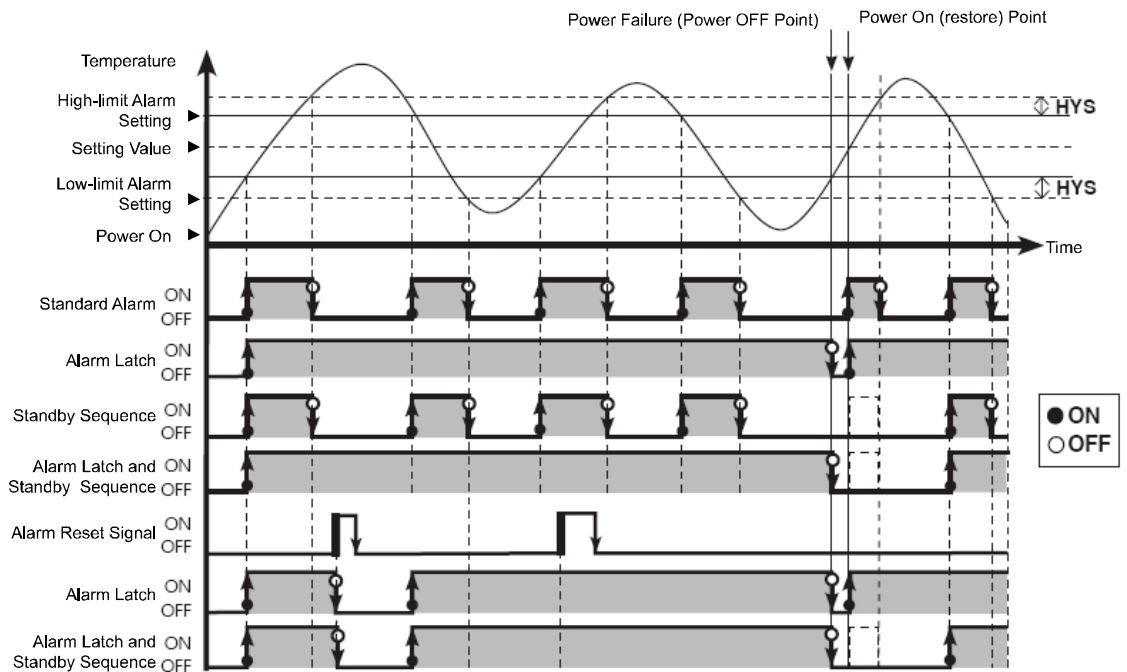

6.4.12.5 Deviation High/Low-limit Alarm (hysteresis overlap)

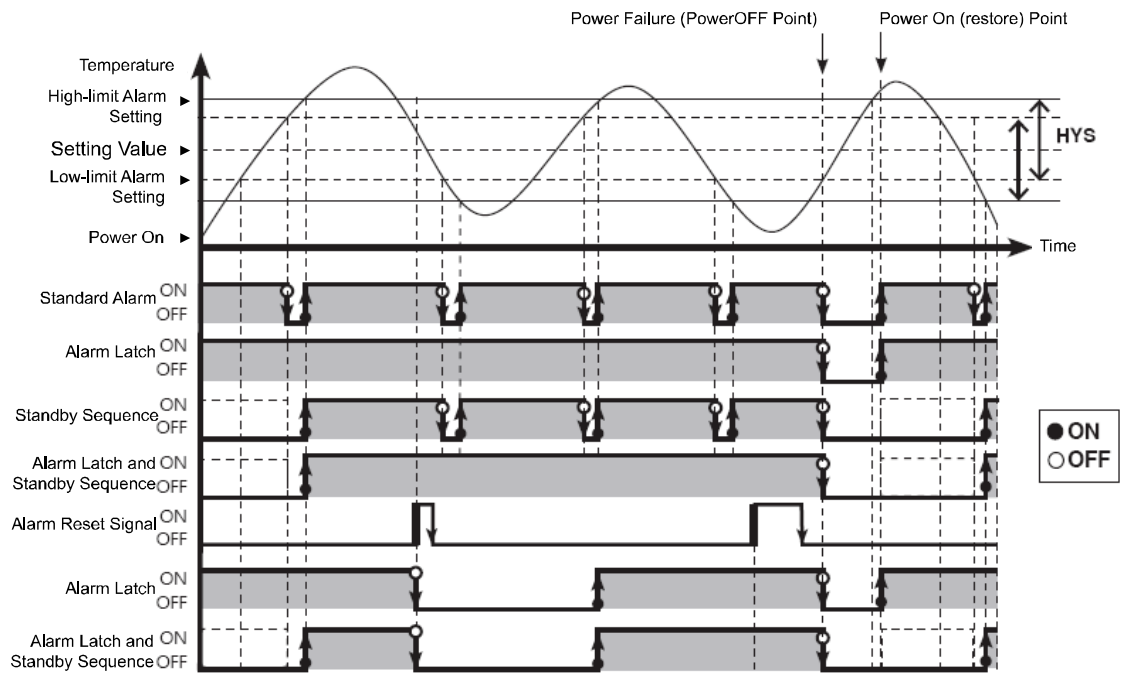

6.5 Communications

- This feature is used for external higher systems (PC, GP, etc.) to set the controller's parameters and to monitor the controller. It can also be used to external devices.
- No redundant unit addresses may exist along the same communication line. The communication cable must be a twist pair that supports RS485.

Interface

Category	Description
Standards	EIA RS 485-compliant
Max. Connections	31 (Address: 01 ~ 31)
Communication	Two-wire, half duplex
Synchronization	Asynchronous
Valid Communication Distance	Max. 800 m
BPS (Bits Per Second)	2400, 4800, 9600, 19200, 38400 bps
Response Standby	5 ms to 99 ms
Communication Start Bit	1 bit (fixed)
Data Bit	8 bit (fixed)
Communication Parity Bit	None, Even, Odd
Communication Stop Bit	1, 2 bit
Protocol	Modbus RTU (character = 11 bit. fixed)

6.5.1 Communication Exchange Number Settings

- You can assign a unique address to each device.
- Users can set communication address using both SW1 (communication address setting switch) and SW2 (communication group change switch).
- Setting range: 01 ~ 31
- Factory default 01

SW1																	
		0	1	2	3	4	5	6	7	8	9	A	B	C	D	E	F
SW2	+0	00	01	02	03	04	05	06	07	08	09	10	11	12	13	14	15
	+16	16	17	18	19	20	21	22	23	24	25	26	27	28	29	30	31







 **Note** If 00 is designated, communications are not performed.

6.5.2 Communications Speed Settings

- You can set the rate of data transmission.

Group	Parameter	Range	Factory Default	Unit
Option Setting Group (Communication Setting)	Bits Per Second	2400, 4800, 9600,19200,38400	9600	bps

- A display LED corresponding to the current bps flashes for 5 seconds (1 second intervals) when the power supply is initially ON.

LED	TM2 Series	TM4 Series	BPS (Bits Per Second)
	PWR	PWR	-
	CH1	CH1	2400
	CH2	CH2	4800
	AL1	CH3	9600
	AL2	CH4	19200
	AL3	-	38400
	AL4	-	-

 **Note**

- It is required to reset controller's POWER (Power OFF -> Power ON) after changing communication speed (bps) via port B.
- One module communication is allowed for Port A. Communication speed is fixed to 9600 bps.
- Make sure that each module has its own communication address. If there are overlapping addresses, parameters for overlapping module cannot be monitored and it may affect the whole communication speed.

6.5.3 Communications Parity Bit Settings

Parity bit is a data communication method that adds an additional bit to each character in transmitted data as an indicator used to verify data loss and corruption. This parameter is used to enable or disable the parity bit option.

SV (Setting Value)	Description
NONE	Disables parity bit.
EVEN	Sets the total bits with signal value of 1 as even numbers.
ODD	Sets the total bits with signal value of 1 as odd numbers.

Group	Parameter	Range	Factory Default	Unit
Option Setting Group (Communication Setting)	Parity Bit	NONE, EVEN, ODD	NONE	-

6.5.4 Communication Stop Bit Settings

You can set the number of bits to mark the end of a transmitted data string.

Setting Value	Description
1	Sets end of data string to 1 bit.
2	Sets end of data string to 2 bit.

Group	Parameter	Range	Factory Default	Unit
Option Setting Group (Communication Setting)	Stop Bit	1, 2	2	-

6.5.5 Response Wait Time Settings

Set a standby time to mitigate communication errors when communicating with a slow master device (PC, PLC, etc.). Once a standby time is set, the controller will respond after the defined standby time has elapsed.

Group	Parameter	Range	Factory Default	Unit
Option Setting Group (Communication Setting)	Response Wait Time	5 ~ 99	20	ms

 Note	Shorter standby times can cause communication errors in the master device.
---	--

6.5.6 Enable/Disable Communications Writing

This feature can change parameter settings stored in memory through communication with PC, GP, PLC, etc., in order to permit or prohibit writing.

Setting Value	Description
ENABLE	Parameter set/change enable via communication.
DISABLE	Prohibit parameter setting or modification via communication.

Group	Parameter	Range	Factory Default	Unit
Option Setting Group (Communication Setting)	Communication Write	ENABLE, DISABLE	ENABLE	-

	Note Reading parameter settings is always permitted.
---	---

6.5.7 USB-to-Serial Connection

Data can be transmitted via a USB-to-serial connection. However, RS485 communication through a USB-to-serial connection is blocked by hardware.

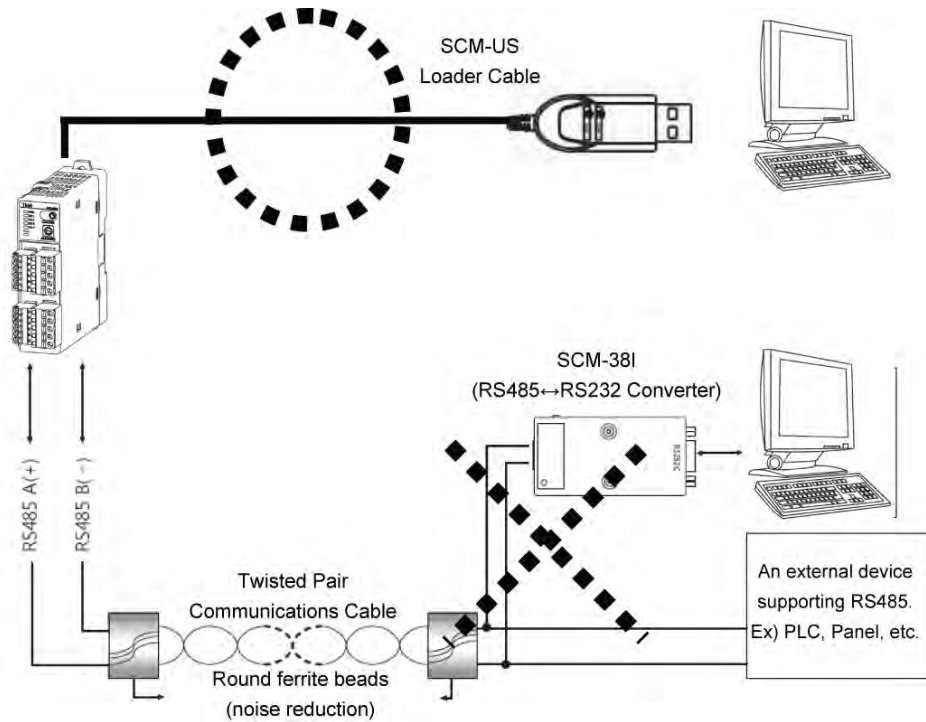

6.6 Additional Features

6.6.1 Monitoring Functionality

6.6.1.1 Control Output MV Monitoring

Monitors and displays the current control output MV.

6.6.1.1.1 Heating MV Monitoring.

- Displays the current heating MV during heating control or heating and cooling control.
- Users may manually adjust the MV to control the temperature.
- Measurement range: 0.0 ~ 100.0%

6.6.1.1.2 Cooling MV Monitoring

- Displays the current cooling MV during cooling control or heating and cooling control.
- Users may manually adjust the MV to control the temperature.
- Measurement range: 0.0 ~ 100.0%

6.6.1.2 Heater current monitoring.

- A feature that monitors and displays the current of a heater (load) being controlled by control output.
- Measurement range: 0.0 to 50.0A

	Note	The current value of a heater (load) is measured and displayed through the current transformer.
---	-------------	---

Group	Parameter	Range	Factory Default	Unit
-	Heating_MV	0.0 ~ 100.0	-	%
-	Cooling_MV	0.0 ~ 100.0	-	%
-	CT1_Heater Current	0.0 ~ 50.0	-	A
-	CT2_Heater Current	0.0 ~ 50.0	-	A

6.6.2 Run/Stop

- Users may run or stop control output by force while in Run mode.
- The STOP command stops the control output. Alarm output, other than control output, maintains the values as set in the alarm output setting at the point of STOP.
- This feature can be enabled by configuring parameters. The digital input terminals (DI-1 and DI-2) can be assigned to the run/stop feature.

 Note	<ul style="list-style-type: none"> ▪ Modifications on RUN/STOP are allowed even when in open state. The STOP status will remain in effect after shutting down the controller and powering it back on. ▪ When STOP is in effect, MV based on the control output at the point of STOP (Stop.MV) is displayed, and continues to be displayed even if a sensor break occurs. ▪ When restarting after STOP, the initial MV is the MV at the end point. ▪ The run/stop setting remains in effect after turning power back on.
---	---

6.6.2.1 Control Output Upon STOP

This sets the control output value upon a STOP. With ON/OFF control, select between 0.0 (OFF) and 100.0 (ON). In PID control, you can directly choose MV within a range of 0.0 to 100.0.

Group	Preceding Condition		Parameter	Range	Factory Default	Unit
Control Setting Group	Heating, Cooling	PID	Stop MV	0.0 ~ 100.0	0.0	%
		ON/OFF		0.0 (OFF)/100.0 (ON)		
	Heating and Cooling	PID		-100.0 (Cool) to 100.0 (Heat)	0.0	
		ON/OFF		-100.0 (Cool ON)/0.0 (OFF)/100.0 (Heat ON)		

 Note	<p>When set to STOP, the preset MV is used for output ignoring the MVs from ON/OFF control and PID control.</p>
---	---

6.6.2.2 Alarm Output Upon STOP

- Enable or disable alarm output upon a stop.
- CONTINUE: Alarm output operates normally.
- OFF Alarm output ceases along with a stop under all conditions.

(However, reverting to Run mode after a stop in alarm latch or alarm latch and standby sequence restores the alarm output to the previous state.)

Group	Parameter	Range	Factory Default	Unit
Control Setting Group	Stop Alarm Out	CONTINUE, OFF	CONTINUE :	-

6.6.3 Multi SV

- Multi SV function allows users to set multiple SVs and save each setting in SV0 ~ SV3. User can change Multi SV number or select desired SV using external DI (Digital Input, DI-1, DI-2) terminal.
- This feature supports up to four SVs which can be independently configurable.

6.6.3.1 Number of Multi SVs

You can set the number of Multi SVs. Select the number of Multi SVs from the controlled subject.

Number of SVs	SV Assignment
1 EA	SV-0
2 EA	SV-0, SV-1
4 EA	SV-0, SV-1, SV-2, SV-3,

6.6.3.2 Multi SV No. Change

You can select the SV to desired control.

 Note	The SV No. selection range varies according to the number of multi SVs.
---	---

6.6.3.3 SV for Multi SVs

Designate the value of each SV for Multi SVs.

Group	Preceding Condition	Parameter	Range	Factory Default	Unit
Control Setting Group	-	Multi SV	1EA, 2EA, 4EA	1EA	-
Operating Group (Control Operation)	Multi SV	Multi SV No.	SV-0 to SV-3	SV-0	-
Operating Group (Control Operation)	Multi SV	SV-0 to SV-3	SV Low-limit to SV High-limit	0	℃, °F

6.6.4 Digital Input

6.6.4.1 Digital Input Terminal Settings

When send the signal to the external digital input (DI-1, DI-2) terminal, the settings of the digital input □_Func parameter will perform. When powers on, it will activate after checking the digital input terminal.

Setting Value	Description
OFF	No function.
STOP	If DI-1,DI-2 terminals are shorted, the stop feature will perform, but to change run/stop through communication will not perform.
AL-RESET	If DI-1,DI-2 terminals are shorted, the forced deactivation of alarm output will perform, but to deactivate the alarm output through communication will not perform.
Manual	If DI-1,DI-2 terminals are shorted, the manual control feature will perform, but to change auto/manual control through communication will not perform.
Multi-SV	By combinational logic of the digital input(DI-1,DI-2), it is possible to select multi SV NO. (SV-0~ SV-3), but it is not possible to select multi SV NO. through communication.

- In the case one of DI-1 or DI-2 being set for Multi SV, SV-0 is selected as the SV if the terminal's external contact signal is off and SV-1 is selected if the signal is on.
- If both DI-1 and DI-2 are configured for Multi SV, you can select the SV using combinational logic of the terminals. If changes multi SV from 4EA to 2EA, the DI-2 will be automatically turned off. If changes multi SV from 4EA to 1EA, both DI-1 and DI-2 will be turned off.

DI-1	DI-2	Multi SV No.
OFF	OFF	SV-0
ON	OFF	SV-1
OFF	ON	SV-2
ON	ON	SV-3

Group	Parameter	Range	Factory Default	Unit
Option Setting Group (Digital Input Setting)	Digital Input 1 Function	OFF, STOP, AL- RESET	STOP	-
	Digital Input 2 Function	Manual, Multi-SV	AL-RESET	-

	Note	Multi SV parameter will be activated only if Multi SV is more than 2.
---	-------------	---

6.6.4.2 Digital Input Terminal Target Channel

Users can set a target channel to which digital input terminal function will be applied.

Group	Parameter	Range	Factory Default	Unit
Option Setting Group (Digital Input Setting)	Digital Input1_Ch	CH1, CH2	CH1	-
	Digital Input2_Ch		CH2	-

6.6.5 Error Detection

- The controller diagnoses input signals for errors and displays messages accordingly. These messages inform the user of device problems.
- The following conditions may result in errors. When an error occurs, the display LED at the front flashes at 0.5 second intervals.
 - The sensor input is higher than operational temperature range.
 - The sensor input is lower than operational temperature range.
 - Input sensor is disconnected or not connected.
- Once the cause of the error is solved (sensor connected/return to display range), the error status is released and the device continues to run normally.

 Note	<ul style="list-style-type: none"> When power is on, or in standard control or heating mode, the controller outputs 0% if HHHH is displayed and 100% if LLLL is displayed. When power is on, or in standard control or cooling mode, the controller outputs 100% if HHHH is displayed and 0% if LLLL is displayed. In heating and cooling mode, when power is on or in standard control, heating output is 0% and cooling output is 100% if HHHH is displayed; heating output 100% and cooling output is 0% if LLLL is displayed. Output priority in manual control: Heating(Cooling)_MV > Stop_MV > Sensor Error_MV Output priority in automatic control: Stop_MV > Sensor Error_MV > Heating(Cooling)_MV
---	---

6.6.5.1 Sensor Error MV.

- This feature sets control output when a sensor open error occurs. Users can configure ON/OFF, MV settings, etc.
- Ignores MV by ON/OFF control or PID control, and sends out a control value based on the defined MV.

Group	Preceding Condition		Parameter	Range	Factory Default	Unit
Control Setting Group	Heating (Cooling)	PID	Sensor Error MV	0.0 ~ 100.0	0.0	%
		ON/OFF		0.0 (OFF)/100.0 (ON)		
	Heating and Cooling	PID		-100.0 (Cool) to 100.0 (Heat)	0.0	
		ON/OFF		-100.0 (Cool ON)/0.0 (OFF)/100.0 (Heat ON)		

6.6.6 Parameter Initialization

This option resets all parameters in memory to factory defaults.

Group	Parameter	Range	Factory Default	Unit
Option Setting Group (Communication Setting)	Parameter Initialize	YES/NO	NO	-

 Note	<ul style="list-style-type: none"> If selecting "Yes", all parameters will be initialized and temperature control will be by factory default. However, communication parameters are not initialized.
---	--

7 Troubleshooting Tips

7.1 Error Display

Display LED is flashing every 0.5 sec or an external connecting device displays error message while using the product.

This is a warning indicating that the external sensor is OPEN. Cut the power to the unit and check if the sensor is connected. If abnormality is found in input sensor connection, disconnect input sensor from controllers and make connection between input (+) terminal and input (-) terminal in order to check whether current ambient temperature is displayed. If current ambient temperature is displayed, it can be inferred that the controller is operating normally. IF HHHH or LLLL is displayed, however, it can be inferred that problems are found on the controller. Please contact Autonics service center. (This error check can be available for only thermocouple type.)

- Make sure a proper input sensor has been selected.

TM2 Series	TM4 Series	LED Status	
		When opening the sensor input	When exceeding the operational temperature range
PWR LED	PWR LED	Red light ON	
CH1 LED	CH1 LED	Flashing in red (0.5 sec. intervals)	
CH2 LED	CH2 LED	Flashing in red (0.5 sec. intervals)	
-	CH3 LED	Flashing in red (0.5 sec. intervals)	
-	CH4 LED	Flashing in red (0.5 sec. intervals)	
Communications output (decimal number)		'31000' output	'30000'(high-limit) output '-30000'(low-limit) output
Program for PC only		Display 'OPEN'	'HHHH (high-limit)' display 'LLLL (low-limit)' display

7.2 Communication Related Tips

No response or abnormal data received on an external device while using the product:

- Make sure no errors are found on communication converter: RS485↔SERIAL Converter (SCM-38I, sold separately), SERIAL↔USB Converter (SCM-US, sold separately).
- Do not tie the communications line with the AC power line.
- Use a separate power supply for the communication converter and the main body if possible.
- If inner circuit is influenced or broken by strong external noise, please consult Autonics service center. In addition, make sure that proper countermeasures are taken for external noise. This product is designed with proper countermeasures for external noise. However, the inner circuit could be damaged by continuous noise that exceeds the range defined in the specifications.

When communication between the main body and external connecting device is not available:

- Check if the power to the converter is on, and if it is wired correctly.
- Check if the communications setting is correct.
- Check if the main body and external devices are properly connected.

7.3 Control Related Tips

Output is not working while using the product.

- Check if the output display LED on the front is working.
- If output display LED is not working, examine every setup parameter. If output display is working, disconnect the wire from the controller to check the output (relay, SSR).

8 DAQMaster

	<p>Note For detailed information, please download a copy of "DAQMaster" manual from our website.</p>
---	---

8.1 Introduction

8.1.1 Overview

DAQMaster is a comprehensive device management program that can be used with Autonics thermometer, meter, and counter products, and with Konics recorder products.

DAQMaster provides GUI control for easy and convenient management of parameters and multiple device data monitoring.

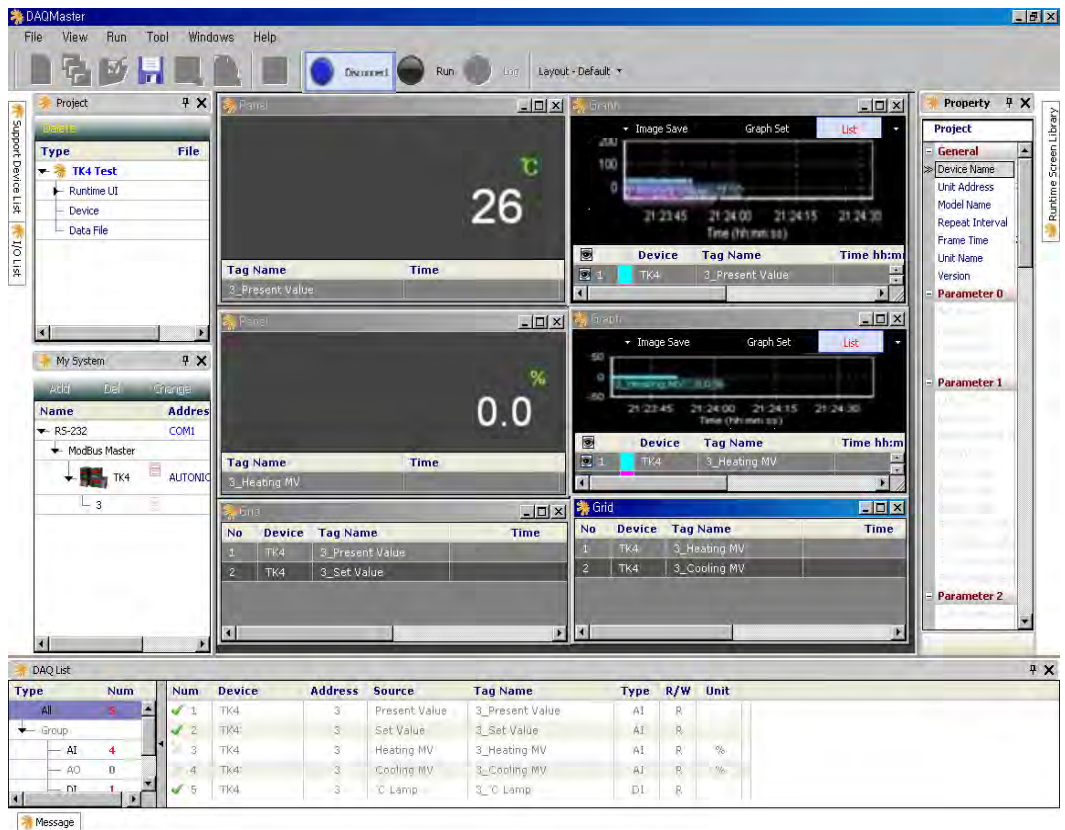



8.1.2 Features

DAQMaster has the following features:

- **Multiple device support**
Simultaneously monitor multiple devices and set parameters.
Simultaneously connect units with different addresses in a single device.
Use Modbus remote terminal unit to enable the use of multiple RS-232 ports.
- **Device scan**
In cases of multiple units (with different addresses) connected together, use unit scan to automatically search for units.
- **Convenient user interface**
Freely arrange the windows for data monitoring, attributes, and projects.
Saving a project also saves the screen layout.
- **Project management**
You can save added device information, data monitoring screen layouts, and I/O source selection as project files. Open project files to load the saved settings.
Provides a project list for simple and easy project file management.
- **Monitoring data log**
When monitoring, save data log files as either DAQMaster data files (.ddf) or CSV (.csv) files. Open files saved in the .csv format directly from Microsoft Excel.
Define log data file naming/saving rules and destination folders to make file management convenient.
- **Data analysis**
Perform spreadsheet and graph analyses of .ddf data files using DAQMaster's data analysis feature. Save spreadsheet data as .rtf, .txt, .html, or .csv files.
- **Modbus map table reporting**
Print address map reports of registered Modbus devices. Modbus map table reports can be saved in .html and .pdf formats.
- **Multilingual support**
Supports Korean, English, Japanese and Simplified Chinese.
To add a different language, modify the files in the Lang folder, rename, and save.

- Script support

Uses the Lua Script language and deals with different I/O processes for individual devices.

с  ISO-9001 

Autonics

Sensors & Controllers

www.autonics.com

Distributor



ООО "РусАвтоматизация"

454010 г. Челябинск, ул. Гагарина 5, оф. 507
тел. 8-800-775-09-57 (звонок бесплатный),
тел.: (351)799-54-26, тел./факс (351)211-64-57
info@rusautomation.ru; www.rusautomation.ru
русавтоматизация.рф

Major products

Proximity sensors • Photoelectric sensors • Area sensors • Fiber optic sensors • Door/Door Side sensors • Pressure sensors • Rotary encoders • Sensor controllers • Switching power supply • Temp. controllers • Temperature/Humidity transducers • Power controllers • Recorders • Tachometer/Pulse(Rate) meters • Panel meters • Indicators • Signal converters • Counters • Timers • Display units • Graphic panel • Stepping Motors & Drivers & Motion controllers

Any proposal for a product improvement and development: Product@autonics.com

Headquarters

41-5, Yongdang-dong, Yangsan-si, Gyeongnam, 626-847, Korea

Overseas Business HQs.

Bldg. 402 3rd Fl., Bucheon Techno Park, 193, Yakdae-dong, Wonmi-gu, Bucheon-si, Gyeonggi-do, 420-734, Korea

Tel: 82-32-610-2730 / Fax: 82-32-329-0728 / E-mail: sales@autonics.com

Brazil

Autonics do Brasil Comercial Importadora Exportadora Ltda

Tel: 55-11-3055-1660 / Fax: 55-11-3055-1661 / E-mail: vendas@autonics.com.br

China

Autonics electronic(Jiaxing) Corporation

Tel: 86-573-8216-1900 / Fax: 86-573-8216-1917 / E-mail: china@autonics.com

India

Autonics Automation India Private Limited

Tel: 91-22-2781-4305 / Fax: 91-22-2781-4518 / E-mail: india@autonics.com

Indonesia

PT. Autonics Indonesia

Tel: 62-21-6586-6740 / Fax: 62-21-6586-6741 / E-mail: Indonesia@autonics.com

Japan

Autonics Japan Corporation

Tel: 81-3-5730-0568 / Fax: 81-3-5730-0569 / E-mail: ja@autonicsjp.co.jp

Malaysia

Mal-Autonics Sensor Sdn. Bhd.

Tel: 60-3-7805-7190(Hunting) / Fax: 60-3-7805-7193 / E-mail: malaysia@autonics.com

Mexico

Autonics Mexico Sales Office

Tel: 52-55-5207-0019 / Fax: 52-55-5207-0099 / E-mail: ventas@autonics.com

Russia

Autonics Corp. Russia Representative Office

Tel/Fax: 7-495-9335-5418 E-mail: russia@autonics.com

Turkey

Autonics Otomasyon Ticaret Ltd. Sti.

Tel: 90-212-222-0117 (PBX) / Fax: 90-212-222-0108 / E-mail: info@autonics.com.tr

USA

Autonics USA, Inc.

Tel: 1-847-680-8160 / Fax: 1-847-680-8155 / E-mail: sales@autonicsusa.net

Vietnam

Autonics Vietnam Representative Office

Tel: 84-8-3925-6563 / Fax: 84-8-3925-6564 / E-mail: vietnam@autonics.com