

QGL/ QGLC

LED Light Bars for Indoor



General lights for built-in AC power converter in compact structure



Cable end M12 connector attached type



Customized Cable end M12 connector attached type available.



Common Specifications(QGL/ QGLC)

- Using aluminum base that protects against heat and stable illumination
- Suitable alternative to fluorescent lighting for situations that require a compact structure with high illumination
- LED direct AC connect system, no need other power device
- 4 kinds of products length 200/300/400/500mm
- Lens options available based on use case- Transparent lens(QGLC) or translucent lens(QGL)
- Removable mount bracket where mounting distance can be adjusted
- Can customize the product with the M12 connector if requested.
- Certificates : CE Compliant

QGL Translucent Lens



QGLC Transparent Lens



Optics Specifications

Model	QGL-200	QGLC-200	QGL-300	QGLC-300	QGL-400	QGLC-400	QGL-500	QGLC-500	
Lens color	Translucent	Transparent	Translucent	Transparent	Translucent	Transparent	Translucent	Transparent	
Light color	Cooldaylight								
Color temperature	6,000-7,000K								
Luminous flux	DC	265lm	332lm	397lm	498lm	595lm	748lm	872lm	997lm
	AC	316lm	358lm	530lm	602lm	720lm	818lm	952lm	1,080lm
Efficacy (lm/W)	DC	70lux	85lux	140lux	170lux	210lux	255lux	280lux	340lux
	AC	85lux	90lux	185lux	205lux	255lux	280lux	310lux	370lux

Specifications

Model	QGL-200/QGLC-200	QGL-300/QGLC-300	QGL-400/QGLC-400	QGL-500/QGLC-500
Voltage	DC24V	DC24V	DC24V	DC24V
	AC110V / AC220V	AC110V / AC220V	AC110V / AC220V	AC110V / AC220V
Range for operation voltage	DC21.5V-26.5V / AC98V-121V / AC198V-245V			
Power consumption	3W	5W	7.5W	10.5W
	4W / 3.5W	7W / 6.5W	9W / 9W	12W / 11.5W
Insulation resistance	Min. 100MΩ(500V DC mega ohm meter)			
Withstanding voltage	DC : 500V AC, 60Hz, 1 minute / AC : 1,500V AC, 60Hz, 1 minute			
Operating temperature	-30°C to +50°C			
Protection rating	Non waterproof			
Materials	Lens : PC, Side cover : ABS, Heat sink : Al, Bracket : STS201			
Certificate	CE DC24V, AC220V only			
Weight(Approx.)	0.12kg	0.17kg	0.23kg	0.28kg
	0.12kg	0.17kg	0.23kg	0.28kg

QGL/QGLC

LED Light Bars for Indoor

Light Distribution and Illuminance

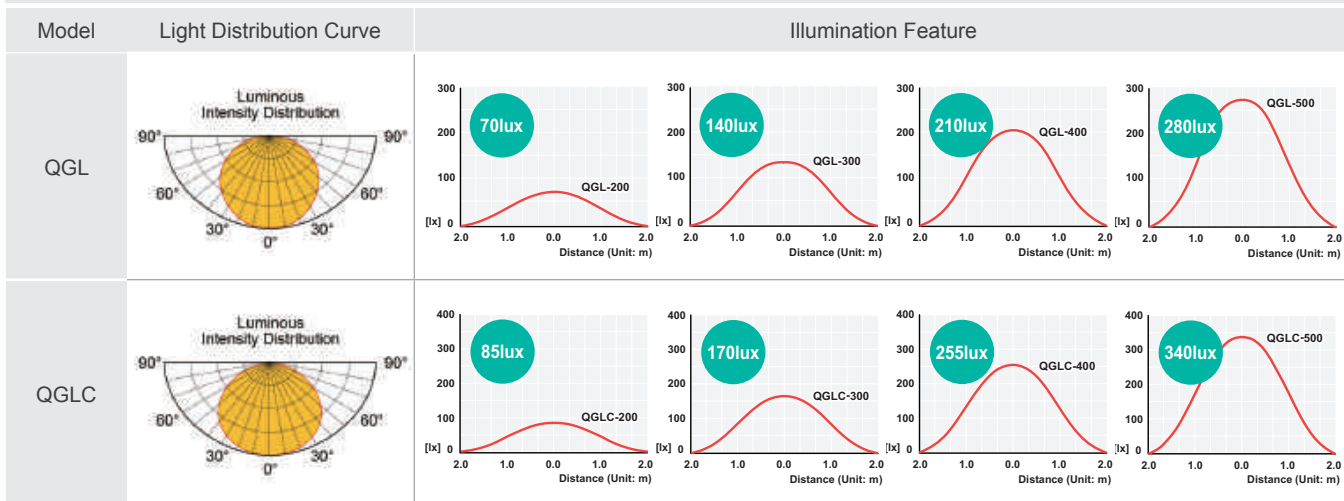

Mounting Structure



※ Adopts removable mounting bracket and sliding structure, adjustable mounting distance.

※ Standard bracket : STS201(2pcs included)

Technical Diagram

(Units : mm)

QGL/ QGLC-200/ 300/ 400/ 500

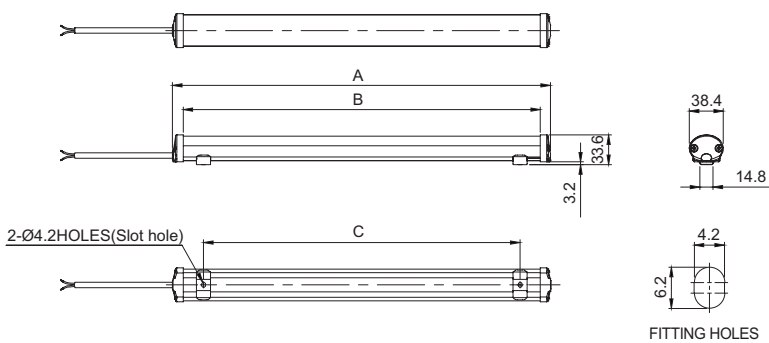

MODEL	A	B	C
QGL/ QGLC-200	200	177	16-130
QGL/ QGLC-300	300	277	16-230
QGL/ QGLC-400	400	377	16-330
QGL/ QGLC-500	500	477	16-430

※ External power line : DC TYPE - UL2464 AWG22(0.3sq×2C) 450mm
AC TYPE - VCTFK(0.75sq×2C) 450mm

Ordering Specification

QGL	300	220
[Model number]	[Product length]	[Voltage]
<ul style="list-style-type: none"> • QGL : Translucent lens • QGLC : Transparent lens 	<ul style="list-style-type: none"> • 200 : 200mm • 300 : 300mm • 400 : 400mm • 500 : 500mm 	<ul style="list-style-type: none"> • 24-DC24V • 110-AC110V • 220-AC220V

ООО "РусАвтоматизация"

454010 г. Челябинск, ул. Гагарина 5, оф. 507
 тел. 8-800-775-09-57 (звонок бесплатный), +7(351)799-54-26, тел./факс +7(351)211-64-57
info@rusautomation.ru; rusautomation.ru; www.rusautomation.ru