

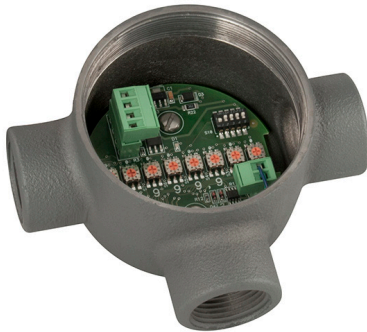

B220-880



B220-881



B220-882



B220-885

CONTENTS

Scope of This Manual	5
Unpacking and Inspection	5
Safety	5
Terminology and Symbols	5
Considerations	5
Electrical Symbols	5
Introduction.	6
Operating Principle	6
Installation.	7
Enclosure Mounting (necessary for CSA certification).	7
Power	7
Turbine Meter.	7
Startup and Configuration.	8
Setting the K-Factor	8
Setting the Output Pulse Width	8
Setting the Output Level.	9
Setting the Internal or External Pullup Resistor.	9
Pulse Output	9
Internal Pullup Resistor.	10
External Pullup Resistor.	10
Specifications.	12
K-Factors Explained	13
Calculating K-Factors	13

SCOPE OF THIS MANUAL

This manual is intended to help you get the K-Factor scalers up and running quickly.

IMPORTANT

Read this manual carefully before attempting any installation or operation. Keep the manual accessible for future reference.

UNPACKING AND INSPECTION

Upon opening the shipping container, visually inspect the product and applicable accessories for any physical damage such as scratches, loose or broken parts, or any other sign of damage that may have occurred during shipment.

NOTE: If damage is found, request an inspection by the carrier's agent within 48 hours of delivery and file a claim with the carrier. A claim for equipment damage in transit is the sole responsibility of the purchaser.

SAFETY

Terminology and Symbols



Indicates a hazardous situation, which, if not avoided, is estimated to be capable of causing death or serious personal injury.



Indicates a hazardous situation, which, if not avoided, could result in severe personal injury or death.



Indicates a hazardous situation, which, if not avoided, is estimated to be capable of causing minor or moderate personal injury or damage to property.

Considerations

The installation of the B220-880 and B220-881 K-Factor scaler must comply with all applicable federal, state, and local rules, regulations, and codes.



IF THE EQUIPMENT IS USED IN A MANNER NOT SPECIFIED BY THE MANUFACTURER, THE PROTECTION PROVIDED BY THE EQUIPMENT MAY BE IMPAIRED.



DANS LE CAS D'UNE UTILISATION NON PRÉVUE PAR LE FABRICANT, LA PROTECTION FOURNIE PAR L'ÉQUIPEMENT PEUT ÊTRE RÉDUITE.



FOR FIELD WIRING CONNECTIONS, WIRE MUST BE RATED AT 158° F (70° C) OR HIGHER.



POUR DES CÂBLAGES SUR LE TERRAIN, LES CÂBLES DOIVENT ÊTRE ÉVALUÉS À 70° C (158° F) MINIMUM.

IMPORTANT

Not following instructions properly may impair safety of equipment and/or personnel.

IMPORTANT

Must be operated by a class 2 power supply suitable for the location.

Electrical Symbols

Function	Direct Current	Caution
Symbol	— — —	

INTRODUCTION

The K-Factor scaler is a field adjustable frequency divider, which interfaces the output signal from a turbine meter with a magnetic pickup to the input of a PLC, RTU, CPU data acquisition card or similar totalizer device. The adjustable frequency divisor, referred to as the K-factor, allows the pulses being sent from a turbine meter to be divided into a recognizable unit that an end device, such as a PLC, can count and display.

Different K-factors allow the device to display in any number of volume measurements such as gallons, cubic meters, liters, barrels and like units. A calibration sheet provided with a turbine meter lists a nominal K-factor or other frequency information specific to that particular flow meter, tested to a specific volumetric flow rate. This K-factor can be placed directly into the K-factor scaler to provide an output with the same volumetric flow rate or modified to a different volumetric flow rate by recalculating the K-factor with the appropriate conversion factor.

In addition, if the K-factor is set to one, the K-factor scaler can be used as a preamplifier where the frequency from a low level turbine meter is proportional to the logic level frequency output needed by a PLC or CPU data acquisition card. This option allows the end device to control the dividing process of the turbine meter output to a recognizable flow rate.

OPERATING PRINCIPLE

Fluid moving through a turbine flow meter causes the rotor to rotate in relation to the flow rate. The rotation of the rotor blades cuts through the magnetic field generated by the magnetic pickup, which generates a frequency output signal that is directly proportional to the speed of the rotor.

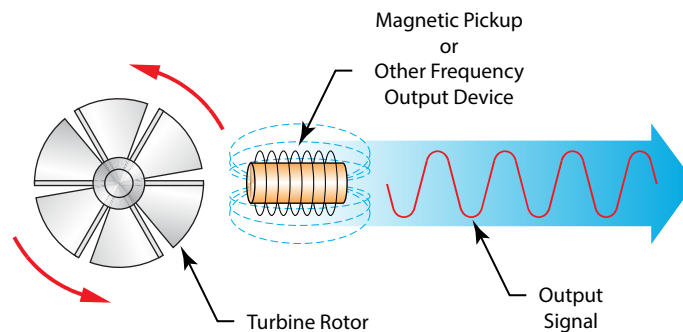

Figure 1: Schematic illustration of electric signal generated by rotor movement

The signal produced is received by the K-factor scaler input amplifier, which has an input sensitivity of $30 \text{ mV}_{\text{p-p}} \dots 30 \text{ V}_{\text{p-p}}$. The signal is then sent to an onboard microcontroller, which acts as a divisor with a range of $1 \dots 999,999,999$. The divisor (K-factor) is user adjustable and set by programming it into the board. The microcontroller handles the dividing process by counting the input pulses and comparing it to the programmed K-factors. Once the count equals this value, an output pulse occurs for a selectable time period and the counting process starts over.

INSTALLATION

The K-Factor scaler was designed with terminal connections with removable plugs for easy connection and removal from the system after installation. See *Figure 2* for the I/O terminal connections. The board connections include voltage input, turbine meter input and the pulse output to a totalizing device.

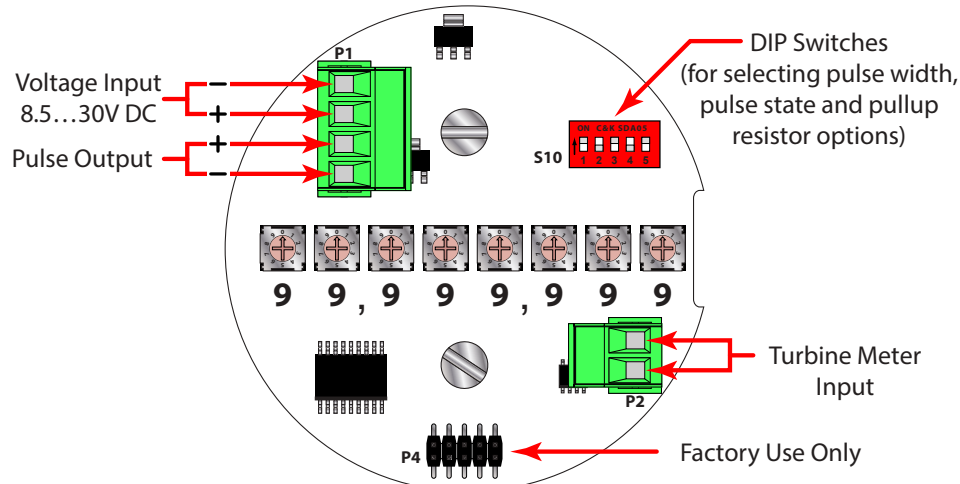

Figure 2: Input/Output terminal connections

Enclosure Mounting (necessary for CSA certification)

If the circuit board assembly is supplied without an enclosure, it must be mounted within a certified Appleton one inch NPT model GRL100-A or GRLB100-A conduit outlet box to maintain the CSA "Ordinary Locations" certification. The label containing the hookup information should be placed on the inside of the cover of the enclosure. The label containing the CSA logo should be placed on the bottom exterior of the enclosure.

Power

The K-factor scaler requires 8.5...30V DC to operate. The power connections are reverse polarity protected by a diode, but must be connected properly for operation of the device. Polarity is shown in *Figure 2*.

Turbine Meter

The turbine meter connections are non-polarized and located on a separate 2-position terminal. Use shielded, twisted pair wire for this connection.

STARTUP AND CONFIGURATION

After the K-factor scaler has been properly installed, apply power. The unit can be configured with the power either on or off. If the power is on, the onboard microcontroller constantly scans for any changes and adjusts accordingly. The pulse output should be ignored while any changes are being made with the power applied. Any changes cause the internal counter to reset and cause the dividing process to start over.

Setting the K-Factor

The K-factor is the ratio of input pulses per each output pulse and can be viewed as a divisor. The minimum K-factor can be set to 1 where each input pulse yields an output pulse. The maximum K-factor can be set to 999,999,999 where it would take this many input pulses to yield one output pulse.

The K-factor is set using the eight rotary switches. Each switch is a ten position switch that is used to select a number from 0...9 by pointing the arrow to the corresponding digit inscribed on its casing. When looking at the K-factor scaler board so that the text 99,999,999 is below the switches, the right most switch represents the least significant digit of the K-factor number (see *Figure 2 on page 7*). For example, to set the K-factor as 4572, the switches should be set as shown in *Figure 3*.

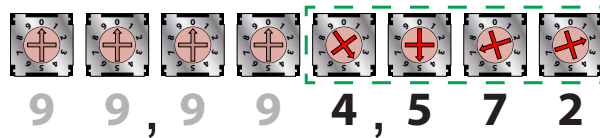

Figure 3: Setting the rotary switches

Setting the Output Pulse Width

The output pulse width is the length of time the pulse remains active before resetting to the resting state. The K-factor scaler has six different pulse widths. Some end devices require that the pulse be a certain length or longer for proper detection of each incoming pulse. For these devices, select a pulse width that is long enough for the end device to recognize.

DIP Switch

The pulse width options are selected by the DIP switch positions 1, 2 and 3. *Table 1* shows the position of each switch to select the correct pulse width output.

Pulse Width	DIP Switch		
	1	2	3
150 μs	▼	▼	▼
1 ms	▲	▼	▼
25 ms	▼	▲	▼
100 ms	▲	▲	▼
500 ms	▼	▼	▲
1 s	▲	▼	▲
Auto	▼	▲	▲
Factory Test	▲	▲	▲

Table 1: DIP switch settings for selecting the width of the output pulse

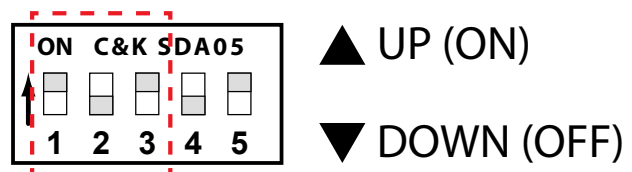

Figure 4: Pulse width settings

Setting the Output Level

Most end devices are unaffected by this setting, but the K-factor scaler board has the ability to invert the output pulse level. This option is controlled by position 4 of the DIP switch.

When the switch is in the off position (see *Figure 5*), the output level is normally low and the duration of the selected pulse width is high. When the switch is in the on position (see *Figure 5*), the output level is normally high and the duration of the selected pulse width is low.

Switch 4 Function		Switch 5 Function	
Output (Normally High)	▲	Internal Pullup used	▲
Output (Normally Low)	▼	External Pullup required	▼

Table 2: Switch 4 and 5 settings

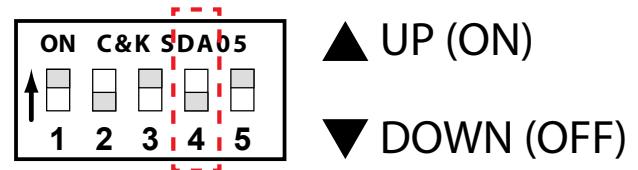

Figure 5: Switch 4 settings

Setting the Internal or External Pullup Resistor

Either the internal pullup resistor or an external resistor must be used for the K-factor scaler board to provide an output pulse. This option is controlled by position 5 of the DIP switch.

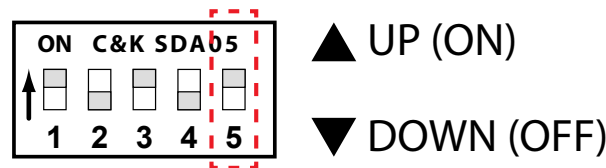

Figure 6: Switch 5 settings

When DIP switch 5 is in the on position (see *Figure 6*), the internal 3.6 k Ω pullup resistor is connected to the input voltage of the board. The output pulse swing is approximately 0.7 volts less than the input voltage to near zero volts.

Setting DIP switch 5 in the off position (see *Figure 6*), the internal pullup resistor is disconnected and an external pullup resistor and supply voltage are required.

Pulse Output

Either the internal or an external pullup resistor is required for the K-factor scaler to provide an output pulse. An onboard jumper controls the pullup resistor selection. With the jumper installed, the internal pullup resistor is connected. Without the jumper, an external pullup is required. See *Table 2* for the I/O terminal connections.

Internal Pullup Resistor

The internal pullup resistor is used for a simple installation. Make sure that the device being connected to the pulse output can accept voltage levels as high as the supply feeding the K-factor scaler. Make sure the output pulse from the K-factor scaler can supply enough current for the receiving device to read the pulse when using an internal pullup resistor. Use the following equation to calculate the available current that the K-factor scaler can supply to the receiving device. See *Figure 7*.

$$\text{Available Current} = \frac{(\text{Input Voltage} - 0.7\text{V})}{(3600\Omega + 47\Omega)}$$

Using the equation above, the maximum current available at an input voltage of 30V is 8 mA. Verify that the receiving device input current requirement is below this value for proper operation. Use an external pullup resistor less than 3.6 k Ω if the value is higher than the available current.

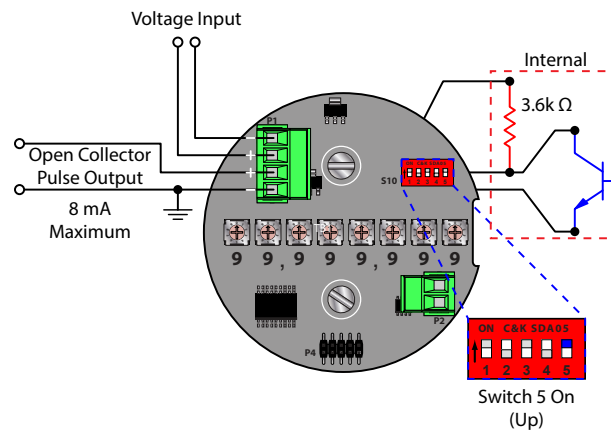

Figure 7: Wiring schematic with internal pullup resistor in circuit

External Pullup Resistor

Using an external pullup resistor creates greater flexibility in controlling the output pulse provided by the K-factor scaler. Power sources and receiving devices differ in individual situation so make sure you are using the correct resistor. Connection of the external pullup resistor is between the receiving device's input and external power source. See *Figure 8*). The power source voltage is the maximum input voltage (of the pulse) to the receiving device. Use the following equation to determine the correct pullup resistor value.

$$R = \frac{\text{Supply Voltage}}{\text{Current}}$$

Where:

R = Resistor value in ohms

Supply Voltage = External supply voltage connected to the external pullup resistor

Current = Input current required by the receiving device in amps

After the resistor value is calculated, make sure in the following equation that power P, the power capability of the output, is less than or equal to 0.25 Watts. Exceeding this value can cause damage to the K-factor scaler circuit. Raising the resistor value decreases the available power output and safeguard the circuit.

$$P = (\text{Supply Voltage}) \left(\frac{\text{Supply Voltage}}{R + 47 \Omega} \right)$$

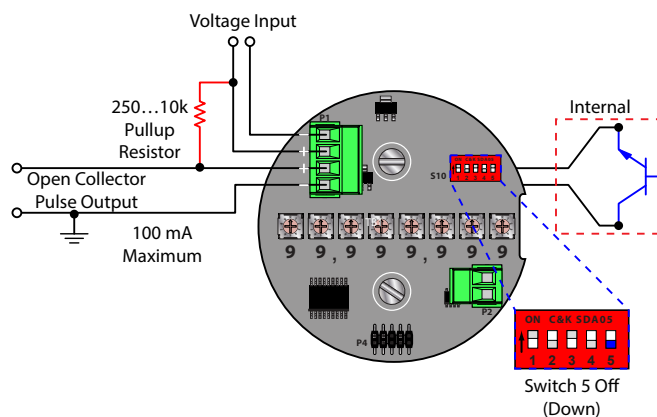

Figure 8: Wiring schematic using an external pullup resistor

To determine the maximum current available using a specific pullup resistor, use the following equation.

$$\text{Current Draw} = \sqrt{\frac{0.25 \text{ Watts}}{\text{External Pullup Resistor}}}$$

SPECIFICATIONS

⚠ CAUTION

FOR THE DEVICES CSA RATING TO BE VALID, THE CIRCUIT BOARD MUST BE MOUNTED IN A CERTIFIED APPLETON 1 IN. MODEL GRL100-A, GRLB100-A OR GRT100-A CONDUIT OUTLET BOX.

External Power	Input voltage	8.5...30V DC (diode protected)
	Maximum current draw	18 mA (using internal resistor @ 30V DC input)
Environmental	Operating temperature	-22...158° F (-30...70° C)
	Altitude	2000 m
	Use	Indoor/outdoor
	Humidity	0...90% non-condensing
Inputs (Magnetic Pickup)	Frequency range	0...4000 Hz
	Trigger sensitivity	30 mV p-p...30V p-p
Output Signal	Max voltage	30V DC
	Max power	0.25 W
Pulse Output (using internal pullup resistor)	Maximum current	8 mA
	VH =	Power input voltage 0.7V DC
	VL =	Less than 0.4V @ maximum input power
	Internal pullup resistor	3.6 kΩ (enabled/disabled by jumper)
Pulse Output (using external pullup resistor)	Maximum current	100 mA
	VH =	Input voltage to external pullup resistor
	VL =	$[VH / (\text{selected resistor value} + 47 \Omega)] \times 47 \Omega$
	Pulse length	150 μs, 1 ms, 25 ms, 100 ms, 500 ms, 1 s, or auto mode
Enclosure Ratings	Model B220-885	Killark aluminum-capped elbow, Y3 CSA approved Class I, Div 1 & 2, Groups C, D; Class II, Div 1 & 2, Groups E, F, G; and Class III
	Models B220-880, B220-881 and B220-882	Appleton GR conduit outlet boxes GRL100-A, GRLB100-A and GRT100-A, CSA approved Class I, Div 1, Groups B, C, D; Class II, Groups E, F, G; and Class III
Certifications	CSA Ordinary location	CAN/CSA-C22.2 No. 61010-1-12, UL Std. No. 61010-1 (3rd Edition)
		Pollution Degree 2, Overvoltage Category I

K-FACTORS EXPLAINED

The K-factor (with regards to flow) is the number of pulses that must be accumulated to equal a particular volume of fluid. You can think of each pulse as representing a small fraction of the totalizing unit.

An example might be a K-factor of 1000 (pulses per gallon). This means that if you were counting pulses, when the count total reached 1000, you would have accumulated one gallon of liquid. Using the same reasoning, each individual pulse represents an accumulation of 1/1000 of a gallon. This relationship is independent of the time it takes to accumulate the counts.

The frequency aspect of K-factors is a little more confusing because it also involves the flow rate. The same K-factor number, with a time frame added, can be converted into a flow rate. If you accumulated 1000 counts (one gallon) in one minute, then your flow rate would be one gpm. The output frequency, in Hz, is found simply by dividing the number of counts (1000) by the number of seconds in a minute (60).

$1000 \div 60 = 16.6666$ Hz. If you were looking at the pulse output on a frequency counter, an output frequency of 16.666 Hz would be equal to one gpm. If the frequency counter registered 33.333 Hz (2×16.666 Hz), then the flow rate would be 2 gpm.

Finally, if the flow rate is two gpm, then the accumulation of 1000 counts would take place in 30 seconds because the flow rate, and hence the speed that the 1000 counts is accumulated, is twice as great.

Calculating K-Factors

Many styles of flow meters are capable of measuring flow in a wide range of pipe sizes. Because the pipe size and volumetric units the meter will be used on vary, it may not possible to provide a discrete K-factor. In the event that a discrete K-factor is not supplied then the velocity range of the meter is usually provided along with a maximum frequency output.

The most basic K-factor calculation requires that an accurate flow rate and the output frequency associated with that flow rate be known.

Example 1

Known values are:

$$\begin{aligned} \text{Frequency} &= 700 \text{ Hz} \\ \text{Flow Rate} &= 48 \text{ gpm} \end{aligned}$$

$$700 \text{ Hz} \times 60 \text{ sec} = 42,000 \text{ pulses per min}$$

$$\text{K-factor} = \frac{42,000 \text{ pulses per min}}{48 \text{ gpm}} = 875 \text{ pulses per gallon}$$

Example 2

Known values are:

$$\begin{aligned} \text{Full Scale Flow Rate} &= 85 \text{ gpm} \\ \text{Full Scale Output Frequency} &= 650 \text{ Hz} \end{aligned}$$

$$650 \text{ Hz} \times 60 \text{ sec} = 39,000 \text{ pulses per min}$$

$$\text{K-factor} = \frac{39,000 \text{ pulses per min}}{85 \text{ gpm}} = 458.82 \text{ pulses per gallon}$$

The calculation is a little more complex if velocity is used because you first must convert the velocity into a volumetric flow rate to be able to compute a K-factor.

To convert a velocity into a volumetric flow, the velocity measurement and an accurate measurement of the inside diameter of the pipe must be known. Also needed is the fact that one US gallon of liquid is equal to 231 cubic inches.

Example 3

Known values are:

$$\begin{aligned} \text{Velocity} &= 4.3 \text{ ft/sec} \\ \text{Inside Diameter of Pipe} &= 3.068 \text{ in.} \end{aligned}$$

Find the area of the pipe cross section.

$$\text{Area} = \pi r^2$$

$$\text{Area} = \pi \left(\frac{3.068}{2} \right)^2 = \pi \times 2.35 = 7.39 \text{ in}^2$$

Find the volume in one foot of travel.

$$7.39 \text{ in}^2 \times 12 \text{ in. (1 ft)} = \frac{88.71 \text{ in}^3}{\text{ft}}$$

What portion of a gallon does one foot of travel represent?

$$\frac{88.71 \text{ in}^3}{231 \text{ in}^3} = 0.384 \text{ gallons}$$

So for every foot of fluid travel 0.384 gallons will pass.

What is the flow rate in gpm at 4.3 ft/sec?

$$0.384 \text{ gallons} \times 4.3 \text{ FPS} \times 60 \text{ sec (1 min)} = 99.1 \text{ gpm}$$

Now that the volumetric flow rate is known, all that is needed is an output frequency to determine the K-factor.

Known values are:

$$\text{Frequency} = 700 \text{ Hz (By measurement)}$$

$$\text{Flow Rate} = 99.1 \text{ gpm (By calculation)}$$

$$700 \text{ Hz} \times 60 \text{ sec} = 42,000 \text{ pulses per gallon}$$

$$\text{K-factor} = \frac{42,000 \text{ pulses per min}}{99.1 \text{ gpm}} = 423.9 \text{ pulses per gallon}$$