

## DIN W48×H48mm, W72×H72mm LCD Display Counter/Timer

### ■ Features

- Improved visibility with LCD display
- Input method: voltage input (PNP)/no-voltage input (NPN) selectable model (by parameter setting), Free voltage input model
- Setting range of one-shot output time: 0.01 sec to 99.99 sec by 0.01 sec unit
- Mounting space saving with compact design (back length: 64.5mm)

#### [Counter]

- Setting range of prescale value: 0.00001 to 99999.9
- Various input/output mode (input: 11 types, output: 11 types)
- Start point (counting value reset) setting
- TOTAL counter display mode  
: Displays the present value and the integrated value simultaneously.

#### [Timer]

- Various output mode (15 types)
- Wide time setting range: 0.001 sec to 99999.9 hour
- '0' time setting function



 Please read "Safety Considerations" in the instruction manual before using.



### ■ Manual

For the detail information, please refer to user manual, and be sure to follow cautions written in the technical descriptions (catalog, website). Visit our website ([www.autonics.com](http://www.autonics.com)) to download manuals.

### ■ Ordering Information

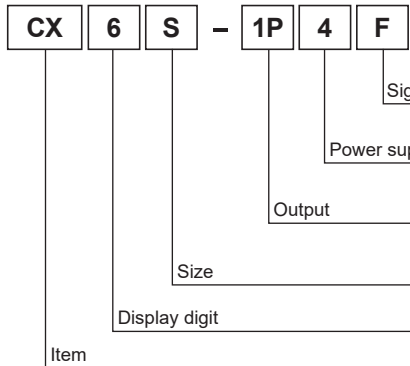

No mark	Voltage input (PNP)/no-voltage input (NPN) selectable type
F	Free voltage input
2	24VAC 50/60Hz, 24-48VDC
4	100-240VAC 50/60Hz
1P	1-stage setting
2P	2-stage setting
S	DIN W48×H48mm
M	DIN W72×H72mm
6	999999 (6-digit)
CX	LCD Display counter/Timer

# CX Series

## Specifications

Model		CX6S-1P□□	CX6S-2P□□	CX6M-1P□□	CX6M-2P□□	
Display digits		6-digit				
Display method		7-segment (1st, 2nd digits of counting value display: white, setting value display: green) LCD method, 11-segment (the other digits of counting value display: white) LCD method, Operation display part: yellow LCD method				
Character size (W×H)	Counting value	4.1×10.1mm		6.2×15.2mm		
	Setting value	3.3×8.1mm		5×12.3mm		
Power supply	AC voltage	100-240VAC~ 50/60Hz				
	AC/DC voltage	24VAC~ 50/60Hz, 24-48VDC==				
Permissible voltage range						
Power consumption	AC voltage	CX6□□□	Max. 6.4VA	Max. 6.7VA	Max. 7.1VA	Max. 7.5VA
		CX6□□□F	Max. 4.2VA	Max. 4.9VA	Max. 4.7VA	Max. 5.4VA
	AC/DC voltage	CX6□□□	AC: max. 5.5VA DC: max. 3.5W	AC: max. 5.6VA DC: max. 3.6W	AC: max. 6.2VA DC: max. 4W	AC: max. 6.3VA DC: max. 4.1W
		CX6□□□F	AC: max. 3.6VA DC: max. 2.5W	AC: max. 4.0VA DC: max. 2.8W	AC: max. 3.9VA DC: max. 2.9W	AC: max. 4.5VA DC: max. 3.3W
Counter	Max. INA/INB counting speed	CX6□□□	Selectable among 1cps/30cps/300cps/1kcps/5kcps			
		CX6□□□F	20cps			
	Counting range	-99999 to 999999				
	Scale	Decimal point up to fifth digit				
	Min. signal width	CX6□□□	RESET, TOTAL RESET signal: selectable among 1ms/20ms			
CX6□□□F		RESET signal: 25ms				
Timer	Time range	999.999s, 9999.99s, 99999.9s, 999999s, 99m 59.99s, 999m 59.9s, 9999m 59s, 99999.9m, 999999m, 99h 59m 59s, 9999h 59m, 99999.9h				
	Operation mode	Up, Down				
	Min. signal width	CX6□□□	INA, INHIBIT, RESET, TOTAL RESET signal: selectable among 1ms/20ms			
		CX6□□□F	INA, INH, RESET signal: 25ms			
	Repeat error	[CX6□□□]-In case of power ON start: max. ±0.01% ±0.05s In case of signal ON start: max. ±0.01% ±0.03s				
	Set error	[CX6□□□F]-In case of power ON start: max. ±0.01% ±0.08s In case of signal ON start: max. ±0.01% ±0.06s				
	Voltage error	[CX6□□□]-In case of power ON start: max. ±0.01% ±0.08s In case of signal ON start: max. ±0.01% ±0.06s				
Temp. error	[CX6□□□F]-In case of power ON start: max. ±0.01% ±0.08s In case of signal ON start: max. ±0.01% ±0.06s					
Input method	CX6□□□	Selectable among voltage input (PNP)/no-voltage input (NPN) [Voltage input (PNP)]-input impedance: 10.8kΩ, [H]: 5-30VDC==, [L]: 0-2VDC [No-voltage input (NPN)]-short-circuit impedance: max. 1kΩ, short-circuit residual voltage: max. 2VDC				
	CX6□□□F	[Free voltage input]-INA (START), INB (INHIBIT) input [H]: 24-240VDC==/24-240VAC~ 50/60Hz, [L]: 0-10VDC/VAC [No-voltage input]-RESET input, short-circuit impedance: max. 1kΩ, short-circuit residual voltage: max. 2V				
One-shot output time						
Control output	Contact	Type	SPDT (1c): 1	SPST (1a): 2	SPDT (1c): 1	SPDT (1c): 2
		Capacity	Max. 250VAC~ 3A, 30VDC== 3A resistive load			
	Solid state	Type	—		NPN open collector: 1	NPN open collector: 2
		Capacity	—		Max. 30VDC== 100mA	
External power supply*1		Max. 12VDC== ±10%, 100mA				
Memory retention		Approx. 10 years (non-volatile memory)				
Insulation resistance		Over 100MΩ (at 500VDC megger)				
Dielectric strength		3,000VAC 50/60Hz for 1 min				
Noise immunity	AC voltage	Square-wave noise by noise simulator (pulse width 1μs) ±2kV				
	AC/DC voltage	Square-wave noise by noise simulator (pulse width 1μs) ±500V				
Vibration	Mechanical	0.75mm amplitude at frequency 10 to 55Hz (for 1 min) in each X, Y, Z direction for 1 hour				
	Malfunction	0.5mm amplitude at frequency 10 to 55Hz (for 1 min) in each X, Y, Z direction for 10 min				
Shock	Mechanical	300m/s <sup>2</sup> (approx. 30G) in each X, Y, Z direction for 3 times				
	Malfunction	100m/s <sup>2</sup> (approx. 10G) in each X, Y, Z direction for 3 times				
Relay life cycle	Mechanical	Min. 5,000,000 operations				
	Malfunction	Min. 100,000 operations				
Protection structure		Front part: IP50 (IEC standard)				
Environment	Ambient temp.	-10 to 55°C, storage: -25 to 65°C				
	Ambient humi.	35 to 85%RH, storage: 35 to 85%RH				
Approval		CE				
Weight*2	AC voltage	CX6□□□	Approx. 157g (approx. 112g)	Approx. 162g (approx. 117g)	Approx. 235g (approx. 170g)	Approx. 240g (approx. 175g)
		CX6□□□F	Approx. 155g (approx. 110g)	Approx. 160g (approx. 115g)	Approx. 233g (approx. 168g)	Approx. 238g (approx. 173g)
	AC/DC voltage	CX6□□□	Approx. 156g (approx. 111g)	Approx. 161g (approx. 116g)	Approx. 234g (approx. 169g)	Approx. 239g (approx. 174g)
		CX6□□□F	Approx. 154g (approx. 109g)	Approx. 159g (approx. 114g)	Approx. 232g (approx. 167g)	Approx. 237g (approx. 172g)

\*1: This is for the voltage input (PNP)/no-voltage input (NPN) selectable model (CX6□□□).

\*2: The weight includes packaging. The weight in parenthesis is for unit only.

※Environment resistance is rated at no freezing or condensation.

# LCD Display Counter/Timer

## ■ Connections

### ◎ CX6S Series

#### 1. Voltage input (PNP), no-voltage input (NPN) selectable model

##### ● CX6S-1P□

**CONTACT OUT:**  
250VAC 3A, 30VDC 3A  
RESISTIVE LOAD

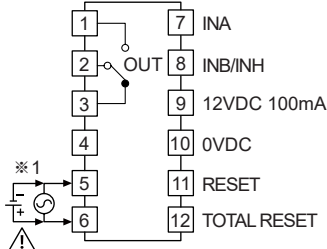

**SOURCE:**  
100-240VAC 50/60Hz 6.4VA  
24VAC 50/60Hz 5.5VA  
24-48VDC 3.5W

##### ● CX6S-2P2

**CONTACT OUT1/OUT2:**  
250VAC 3A, 30VDC 3A  
RESISTIVE LOAD

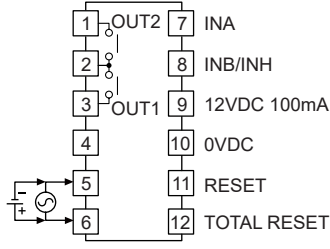

**SOURCE:**  
24VAC 50/60Hz 5.6VA  
24-48VDC 3.6W

##### ● CX6S-2P4

**CONTACT OUT1/OUT2:**  
250VAC 3A, 30VDC 3A  
RESISTIVE LOAD

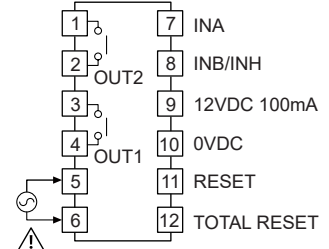

**SOURCE:**  
100-240VAC 50/60Hz 6.7VA

#### 2. Free voltage input model

##### ● CX6S-1P□F

**CONTACT OUT**  
: 250VAC 3A, 30VDC 3A  
RESISTIVE LOAD  
**SIGNAL INPUT**  
: 24-240VAC 50/60Hz, 24-240VDC

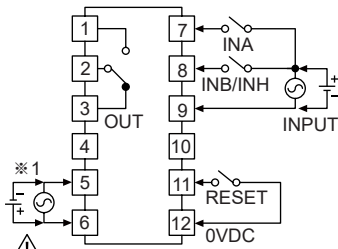

**SOURCE:** 100-240VAC 50/60Hz 4.2VA  
24VAC 50/60Hz 3.6VA  
24-48VDC 2.5W

##### ● CX6S-2P2F

**CONTACT OUT1/OUT2**  
: 250VAC 3A, 30VDC 3A  
RESISTIVE LOAD  
**SIGNAL INPUT**  
: 24-240VAC 50/60Hz, 24-240VDC

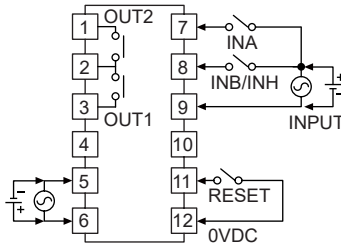

**SOURCE:** 24VAC 50/60Hz 4.0VA  
24-48VDC 2.8W

##### ● CX6S-2P4F

**CONTACT OUT1/OUT2**  
: 250VAC 3A, 30VDC 3A  
RESISTIVE LOAD  
**SIGNAL INPUT**  
: 24-240VAC 50/60Hz, 24-240VDC

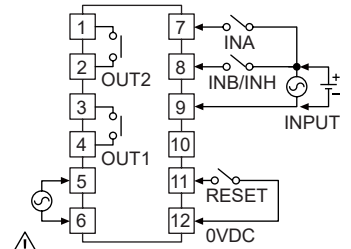

**SOURCE:** 100-240VAC 50/60Hz 4.9VA

# CX Series

## ■ Connections

### ◎ CX6M Series

#### 1. Voltage input (PNP), no-voltage input (NPN) selectable model

##### ● CX6M-1P□

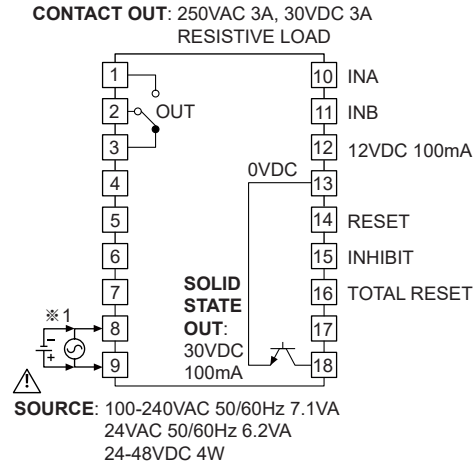

##### ● CX6M-2P□

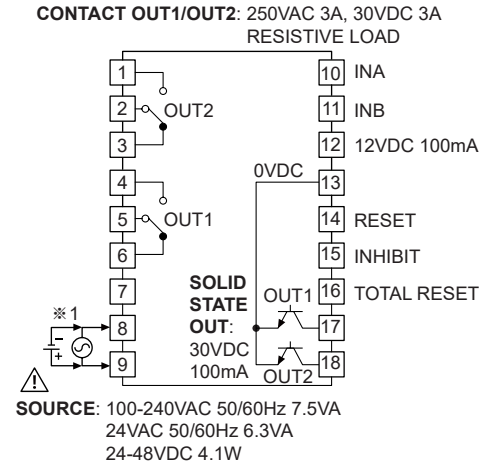

#### 2. Free voltage input model

##### ● CX6M-1P□F

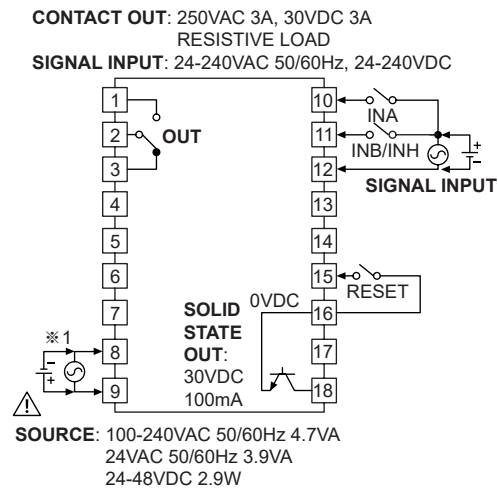

##### ● CX6M-2P□F

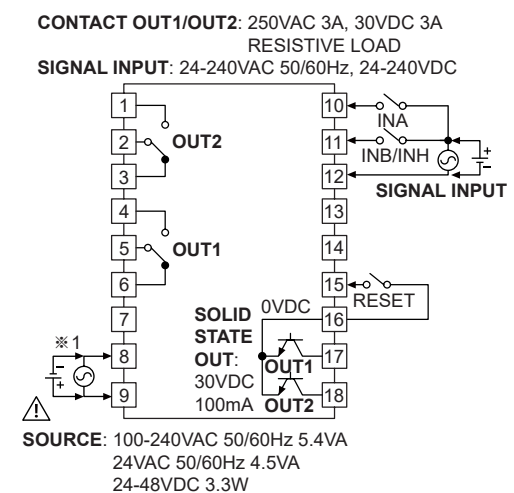

※1: AC voltage type: 100-240VAC 50/60Hz  
AC/DC voltage type: 24VAC 50/60Hz, 24-48VDC

# LCD Display Counter/Timer

## ■ Dimensions

(unit: mm)

### ○ CX6S Series

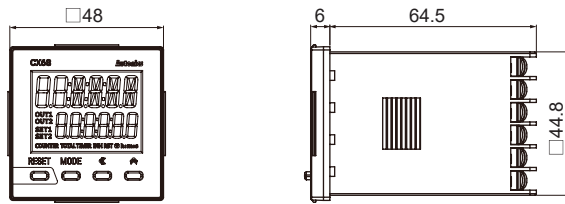

### ○ Panel cut-out

#### ● CX6S Series

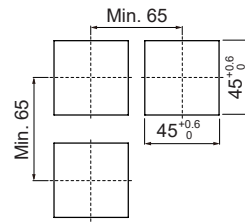

### ○ CX6M Series

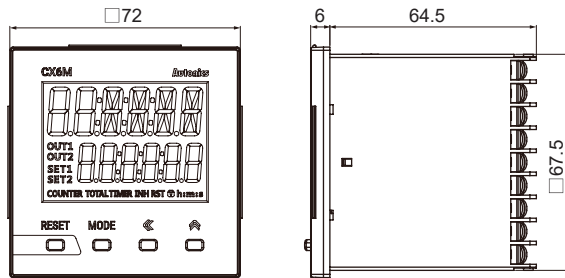

#### ● CX6M Series

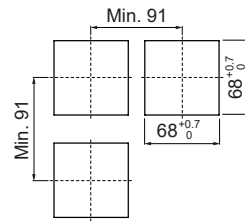

### ○ Bracket

#### ● CX6S Series

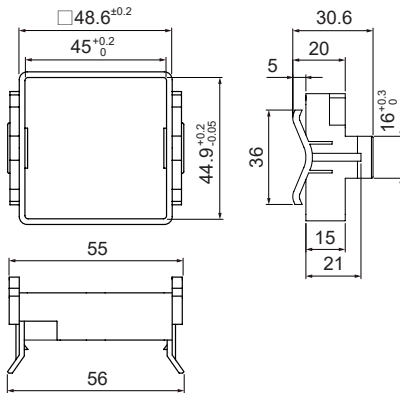

#### ● CX6M Series

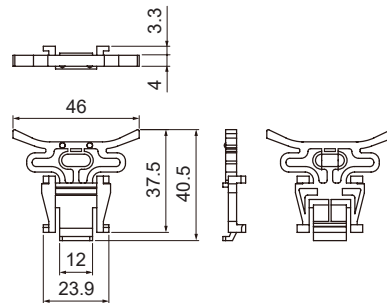

### ○ Terminal cover (sold separately)

#### ● CX6S Series

(RSA-COVER, 48×48mm)

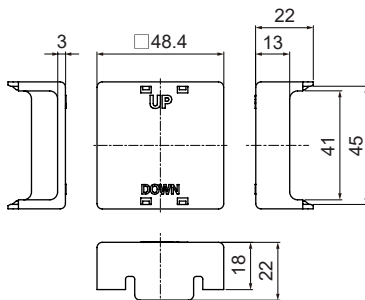

#### ● CX6M Series

(RMA-COVER, 72×72mm)

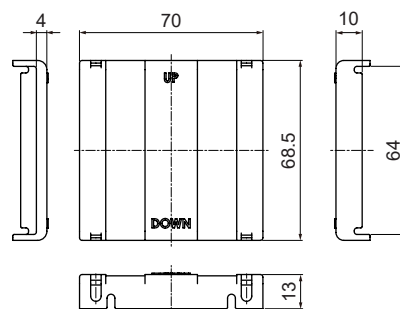

# CX Series

## Unit Description

### ○ CX6S Series

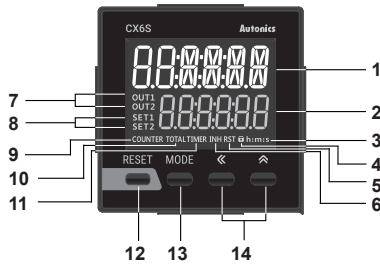

### ○ CX6M Series

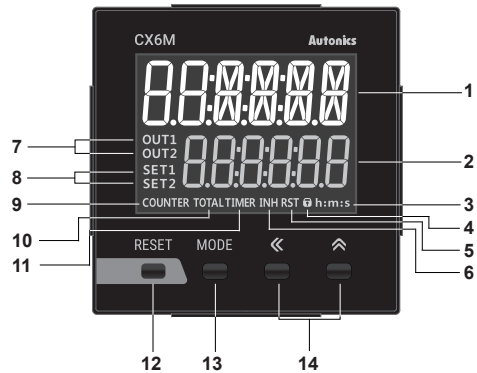

#### 1. Counting value display component (white)

RUN mode: Displays counting value for counter operation or time progress value for timer operation.  
Function setting mode: Displays parameter.

#### 2. Setting value display component (green)

RUN mode: Displays setting value.  
Function setting mode: Displays parameter setting value.

#### 3. Time unit indicator (h:m:s): Turns ON for time unit for timer.

#### 4. Key lock indicator (🔒): Turns ON for key lock setting.

#### 5. Reset input indicator (RST): Turns ON for reset key input or reset signal input.

#### 6. INH indicator (INH)

For the voltage input (PNP)/no-voltage input (NPN) selectable model (CX6□□□□), it turns ON for INHIBIT signal input.  
(In case of CX6S Series and timer mode, it turns ON for INB/INH signal input.)

For free voltage input model (CX6□□□□F), it turns ON for INB/INH signal input for timer.

#### 7. Output indicator (OUT1, OUT2): Turns ON for the dedicated control output ON.

#### 8. SV checking and changing indicator (SET, SET1, SET2) (green): Turns ON when checking and changing SV.

#### 9. COUNTER indicator (COUNTER): Turns ON for counter operation.

#### 10. TOTAL indicator\*<sup>1</sup> (TOTAL): In case of TOTAL counter display mode, it turns ON with the COUNTER indicator.

#### 11. TIMER indicator (TIMER): Flashes (progressing time) or Turns ON (stopping time) for timer operation.

#### 12. [RESET] key

RUN mode, Function setting mode: Press the [RESET] key to reset the counting value and turn OFF the output.  
TOTAL counter display mode\*<sup>1</sup>: Press the [RESET] key to reset the counting value of TOTAL counter.

#### 13. [MODE] key

RUN mode: Hold the [MODE] key over 3 sec to enter function setting mode.

Press the [MODE] key to select SV2 (SET2)/SV1 (SET1)/TOTAL counter\*<sup>1</sup> display for counter operation.

Function setting mode: Hold the [MODE] key over 3 sec to return RUN mode.

Press the [MODE] key to save the SV and enter the next setting.

Function setting check mode: Hold the [MODE] key over 1 sec to return RUN mode.

Changing SV mode: Press the [MODE] key to save SV and return RUN mode.

#### 14. [←], [→] key

##### 1) [←] key

RUN mode: Press the [←] key to change SV and move SV (SET, SET1, SET2) digits.  
Changing SV mode: Press the [←] key to change digits.

##### 2) [→] key

Changing SV mode: Increases SV.  
Function setting mode: Changes the settings.

\*<sup>1</sup>: This is for the voltage input (PNP)/no-voltage input (NPN) selectable model (CX6□□□□).

# LCD Display Counter/Timer

## Input Connections

### ⊙ No-voltage input (NPN)

#### ● Solid-state input (standard sensor: NPN output type sensor)

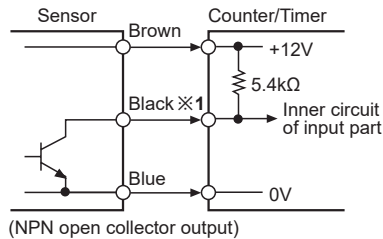
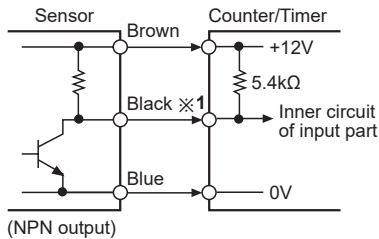

#### ● Contact input

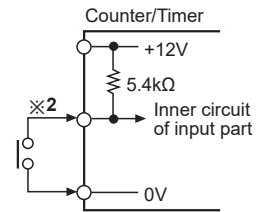

※1: CP1, CP2 (INHIBIT), SET input part

※2: Set counting speed as 1 or 30cps.

### ⊙ Voltage input (PNP)

#### ● Solid-state input (standard sensor: PNP output type sensor)

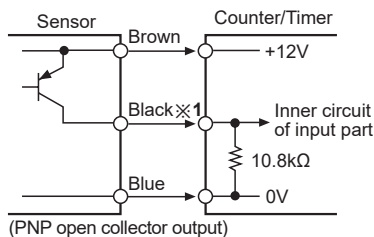
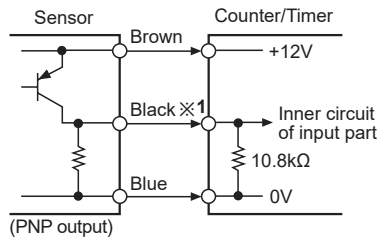

#### ● Contact input

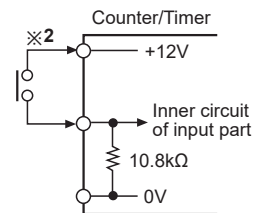

※1: CP1, CP2 (INHIBIT), SET input part

※2: Set counting speed as 1 or 30cps.

## Output Connections

### ⊙ Contact output

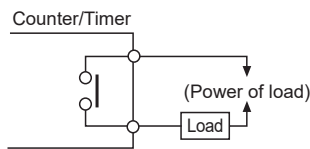

※Select the load which capacity is not over contact capacity.

### ⊙ Solid-state output

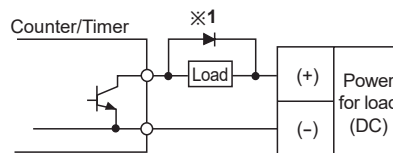

※For solid state output, select load power and load not to be over (max. 30VDC, 100mA), switching capacity.

※Do not supply reverse polarity voltage.

※1: For using inductive load (relay, etc.), connect surge absorber (diode, varistor etc.) at the both ends of load.

# CX Series

## Operations and Functions (counter/timer)

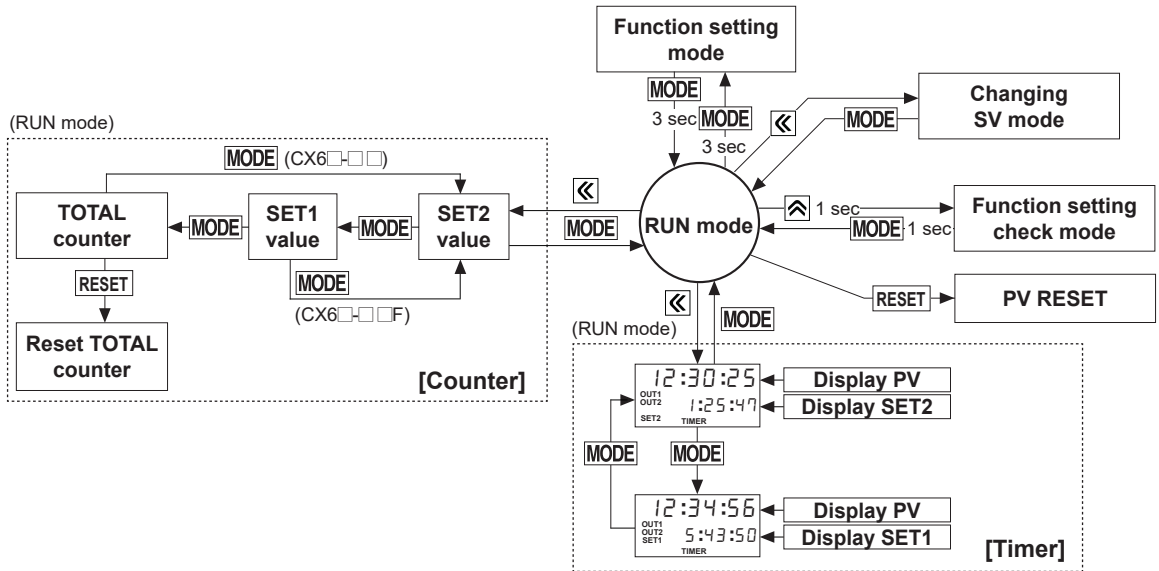

## Counter mode

### Changing SV mode

When input signal is ON during changing SV, it operates counting and output control.

It is available to set SV as '0' and the dedicated output for SV '0' occurs.

There are output mode which cannot set SV as '0'. (the setting value display component flashes three times when SV is set as '0')

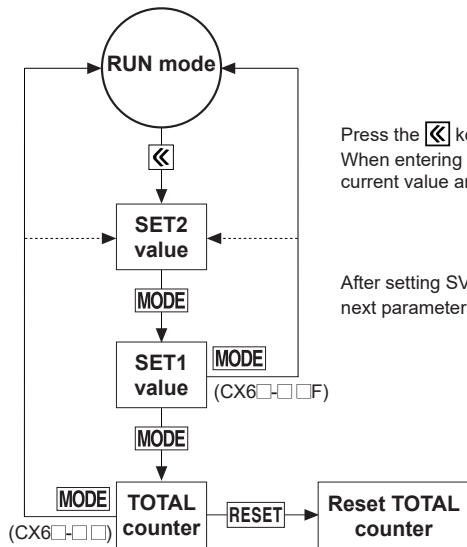

Press the key to enter changing SV mode in RUN mode.

When entering changing SV mode, the counting value display component displays the current value and the setting value display component displays SV.

After setting SV at each parameter, press the key to save SV and it moves next parameter setting or returns to RUN mode.



# LCD Display Counter/Timer

## • Function setting mode

- ※1: In case of free voltage input model (CX6□□□□F), these parameters do not appear due to fixed setting.
- ※2: This parameter is for the voltage input(PNP)/no-voltage input(NPN) selectable model (CX6□□□□).
- ※: When changing the setting of shaded parameters, all output turn OFF.

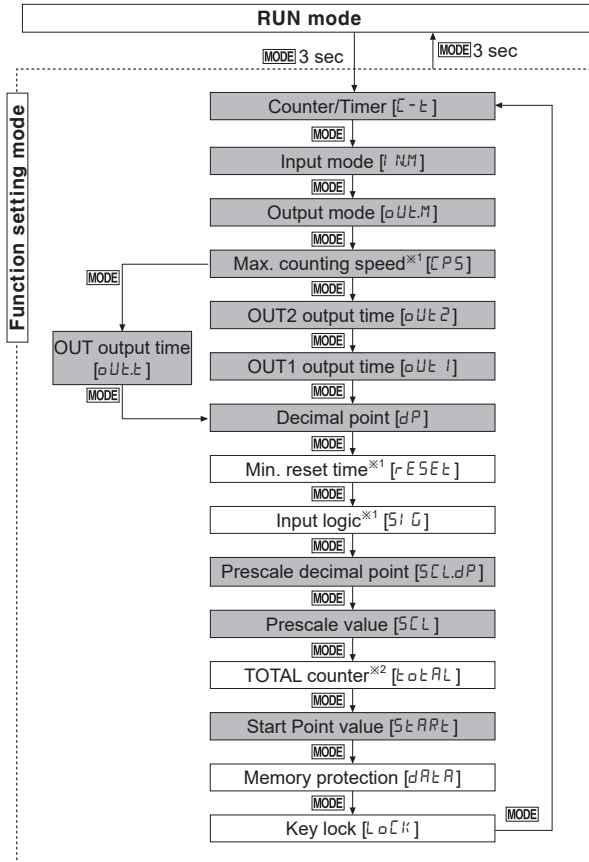

-Hold the **MODE** key over 3 sec in RUN mode and it enters function setting mode.

-Hold the **MODE** key over 3 sec in function setting mode and it returns to RUN mode.

## • Function setting check mode (only for free voltage input model (CX6□□□□F))

- When checking the saved parameters, press the **MODE**, **↔** key to check next item.
- At function setting check mode, the counting value display component displays the parameters and the setting value display component displays the SV of the parameters.

## • Checking SV of TOTAL counter

- At TOTAL counter operation, the counting value display component displays the current value and the setting value display component displays TOTAL counter counting value.
- ※When TOTAL counter counting value is over 999999, it counts from 0 again.

## • Switching display of the setting value display component

(only for voltage input (PNP)/no-voltage input (NPN) selectable model (CX6□□□□))

- In case of 2-stage setting model(CX6□□-2P□□), whenever pressing the **MODE** key, each SET2, SET1, TOTAL COUNTER value displays consecutively.

## • Display HOLD output mode for counter

- It displays the over value of prescale value.
- When SV is n multiplied by prescale value and the display value after HOLD output mode and SV are different, the prescale value is not the 1/n time of SV.

## • RESET

- In RUN mode, function setting mode, press the **RESET** key to reset the current value and the output turns OFF.
- At TOTAL counter display mode, press the **RESET** key to reset TOTAL counter counting value and the current counting value.

# CX Series

## Parameter Setting (Counter)

(MODE) key: moves parameters, (F) key: changes parameter setting value)

Parameter	Parameter setting value
Counter/Timer [C-t]	COUNT ↔ t1 nE ※[COUNT: Counter t1 nE: Timer
Input mode [I-NM]	UP → UP-1 → UP-2 → UP-3 → dn → dn-1 ↑ Ud-C*1 ← Ud-b*1 ← Ud-A ← dn-3 ← dn-2
Output mode [OUT.M]	<ul style="list-style-type: none"> <li>Input mode is UP, UP-1, UP-2, UP-3 or dn, dn-1, dn-2, dn-3, F → n → C → r → E → P → Q → R</li> <li>Input mode is Ud-A, Ud-b*1, Ud-C*1 F → n → C → r → E → P → Q → R → S → t → d</li> </ul> ※If max. counting speed is 5kcps, and output mode is d, max. counting speed is automatically changed as 30cps, factory default.
Max. counting speed*2 [CP5]	30 → 300 → 1k → 5k → 1 ↑ ※Max. counting speed is when duty ratio of INA or INB input signal is 1:1. It is applied for INA, or INB input as same. ※When output mode is d, set max. counting speed one among 1cps, 30cps, 300cps, or 1kcps.
OUT 2 output time*3 [OUT2]	※Set one-shot output time of OUT 2. ※Setting range: 00.01 to 99.99 sec ※When output mode is F, n, S, t, d, this parameter does not appear. (fixed as HOLD)
OUT 1 output time*3 [OUT1]	※Set one-shot output time of OUT 1. ※Setting range: 00.01 to 99.99 sec, Hold ※When number of tens digit is flashing, press the (F) key once and Hold appears. ※When output mode is S, t, d, this parameter does not appear. (fixed as HOLD)
OUT output time*3 [OUTt]	※Setting range: 00.01 to 99.99 sec ※When output mode is F, n, S, t, d, this parameter does not appear. (fixed as HOLD)
Decimal point*4 [dP]	↑ ※Decimal point is applied to PV and SV.
Min. reset time*2 [RESEt]	1 ↔ 20, unit: ms ※Set min. width of external reset signal input.
Input logic*2 [S1G]	nPN: No-voltage input, PnP: Voltage input
Prescale decimal point*4 [SCLP]	↑ ※Decimal point of prescale should not set smaller than decimal point [dP].
Prescale value [SCL]	※Setting range: 0.00001 to 99999.9 ※Setting range of prescale is linked with prescale decimal point [SCLP] setting.
TOTAL counter*1 [tOTAL]	on ↔ OFF
Start point value [START]	※Setting range of start point value is linked with decimal point [dP] setting. (0.00000 to 999999) ※When input mode is dn, dn-1, dn-2, this parameter does not appear. ※When total count function is ON, this parameter does not appear.*1
Memory protection [dRtR]	CLR ↔ rEC ※CLR: Resets the counting value when power OFF. rEC: Maintains the counting value when power OFF. (memory protection)
Key lock [LoCK]	LoFF → LoC.1 ↑ LoC.3 ← LoC.2 ※LoFF: Unlock keys, key lock indicator turns OFF LoC.1: Locks (RESET) key, key lock indicator turns ON LoC.2: Locks (F), (F) keys, key lock indicator turns ON LoC.3: Locks (RESET), (F), (F) keys, key lock indicator turns ON

※1: For voltage input (PNP), no-voltage input (NPN) model (CX6□□□).

※2: For free voltage input model(CX6□□□F), these parameters do not appear due to fixed setting.

※3: For 1-stage setting model (CX6□1P□□), OUT 1 does not appear.

The OUT2 output time is displayed as OUTt.

※4: Decimal point and prescale decimal point

-Decimal point: Set the decimal point for display value regardless of prescale value.

-Prescale decimal point: Set the decimal point for prescale value of counting value regardless of display value.

# LCD Display Counter/Timer

## Input Operation Mode (Counter)

Input mode	Counting chart	Operation
UP [UP]		<p>※When INA is counting input, INB is no counting input.                      When INB is counting input, INA is no counting input.</p>
UP-1 [UP-1]		<p>※When INA input signal is rising ( <math>\uparrow</math> ), it counts.                      ※INA: Counting input                      ※INB: No counting input</p>
UP-2 [UP-2]		<p>※When INA input signal is falling ( <math>\downarrow</math> ), it counts.                      ※INA: Counting input                      ※INB: No counting input</p>
UP-3 [UP-3]		<p>※When INA or INB input signal is rising ( <math>\uparrow</math> ), it counts.                      ※INA: Counting input                      ※INB: Counting input</p>
Down [DN]		<p>※When INA is counting input, INB is no counting input.                      When INB is counting input, INA is no counting input.</p>
Down-1 [DN-1]		<p>※When INA input signal is rising ( <math>\uparrow</math> ), it counts.                      ※INA: Counting input                      ※INB: No counting input</p>
Down-2 [DN-2]		<p>※When INA input signal is falling ( <math>\downarrow</math> ), it counts.                      ※INA: Counting input                      ※INB: No counting input</p>

# CX Series

## Input Operation Mode (Counter)

Input mode	Counting chart	Operation
Down-3 [d n - 3]		※When INA or INB input signal is rising (  ), it counts. ※INA: Counting input ※INB: Counting input
Up/ Down-A [U d - A]		※INA: Counting input INB: Counting command input ※When INB is "L", counting command is up. When INB is "H", counting command is down.
Up/ Down-B [U d - b]		※INA: Up counting input INB: Down counting input ※When INA and INB input signals are rising (  ) at the same time, it maintains previous value.
Up/ Down-C [U d - C]		※When connecting encoder output A, B phase with counter input, INA, INB, set input mode [ U d - C ] as phase different input [ U d - C ] for counter operation.

※A: over min. signal width, B: over than 1/2 of min. signal width. If the signal is smaller than these width, it may cause counting error ( $\pm 1$ ).

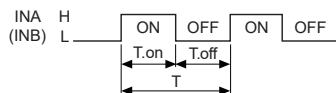

※T.on, T.off: Min. signal width

※The meaning of "H", "L"

Character	Input method	Voltage input (PNP)	No-voltage input (NPN)
H		5-30VDC	Short
L		0-2VDC	Open

※Min. signal width by counting speed

[CX6□□□]

Counting speed	Min. signal width
1cps	500ms
30cps	16.7ms
300cps	1.67ms
1kcps	0.5ms
5kcps	0.1ms

[CX6□□□F]

Counting speed	Min. signal width
20cps	25ms

# LCD Display Counter/Timer

## Output Operation Mode (Counter)

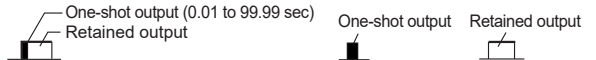

Output mode	Input mode			Operation
	Up, Up-1, 2, 3	Down, Down-1, 2, 3	Up/Down A, B, C	
F [F]				<ul style="list-style-type: none"> <li>After count-up, counting display value increases or decreases until reset signal is applied and retained output is maintained.</li> </ul>
N [r]				<ul style="list-style-type: none"> <li>After count-up, counting display value and retained output are maintained until reset signal is applied.</li> </ul>
C [c]				<ul style="list-style-type: none"> <li>When count-up, counting display value will be reset and count simultaneously.</li> <li>OUT1 retained output will be off after OUT2 one-shot time.</li> <li>The one-shot output time of OUT1 one-shot output time is operated regardless of OUT2 output.</li> </ul>
R [r]				<ul style="list-style-type: none"> <li>After count-up, counting display value is reset after one-shot output time of OUT2 and it counts simultaneously.</li> <li>OUT1 retained output will be off after OUT2 one-shot time.</li> <li>OUT1 one-shot output time is operated regardless of OUT2 output.</li> </ul>
K [c]				<ul style="list-style-type: none"> <li>After count-up, counting display value increases or decreases until RESET input is applied.</li> <li>OUT1 retained output is off after OUT2 one-shot time.</li> <li>OUT1 one-shot output time is operated regardless of OUT2 output.</li> </ul>
P [P]				<ul style="list-style-type: none"> <li>After count-up, counting display value is maintained while OUT2 output is on. Counting value is internally reset and counts simultaneously.</li> <li>When OUT2 output is off, displays counting value while OUT2 is ON, and it increases or decreases.</li> <li>OUT1 retained output is off after OUT2 one-shot time.</li> <li>OUT1 one-shot output time is operated regardless of OUT2 output.</li> </ul>
Q [q]				<ul style="list-style-type: none"> <li>After count-up, counting display value increases or decreases during OUT2 one-shot time.</li> <li>OUT1 retained output is off after OUT2 one-shot time.</li> <li>OUT1 one-shot output time is operated regardless of OUT2 output.</li> </ul>
A [R]				<ul style="list-style-type: none"> <li>After count-up, counting display value and OUT1 retained output are maintained until RESET input is applied.</li> <li>OUT1 one-shot output time is operated regardless of OUT2 output.</li> </ul>

※OUT 1 is available to set as '0' regardless of output mode. The output for '0' setting executes.  
 ※In case of C, r, P, q output mode for OUT2, setting '0' is not available.

# CX Series

## ■ Output Operation Mode (Counter)

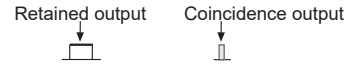

Output mode	Input mode Up/Down A, B, C	Operation
S [5]		※OUT1 keeps ON status in following condition : Counting display value $\geq$ SET1 ※OUT2 keeps ON status in following condition : Counting display value $\geq$ SET2
T [t]		※OUT1 output is off : Counting display value $\geq$ SET1 (when SET1 is 0, OUT1 output maintains ON state.) ※OUT2 keeps ON status in following condition : Counting display value $\geq$ SET2
D [d]		※When counting display value is equal to setting value (SET1, SET2) only, OUT1 or OUT2 output keeps ON status. ※When setting 1kcps for counting speed, solid state contact output should be used. (when using contact output, it is difficult to execute normal output operation due to contact reaction time.)

※OUT 1 is available to set as '0' regardless of output mode. The output for '0' setting executes.

※In case of C, r, P, q output mode for OUT 2, setting '0' is not available.

## ■ Output Operation for Other Conditions

### ○ When Start Point is larger or equal than setting value (UP, UP-1, UP-2, UP-3, Ud-A, Ud-b, Ud-C mode)

#### ● When setting SET2>Start Point>SET1

-UP, UP-1, UP-2, UP-3 mode: Output of OUT 1 does not execute. When PV is same as SET2, output of OUT 2 turns ON.

-Ud-A, Ud-b\*1, Ud-C\*1 mode: When PV counts down and is same as SET1, output of OUT 1 turns ON.

#### ● When setting SET2>Start Point=SET1

-In case of UP, UP-1, UP-2, UP-3, Ud-A, Ud-b\*1, Ud-C\*1 mode, output of OUT1 turns ON when RESET ON to OFF.

※1: This is for the voltage input(PNP)/no-voltage input(NPN) selectable model (CX6□□□).

### ○ When SET1 is larger or equal than SET2 at down mode

#### ● When SET2>SET1

-Output of OUT 1 does not execute.

#### ● When SET2=SET1

-Output of OUT 1 turns ON for RESET OFF.

# LCD Display Counter/Timer

## ■ Prescale Function (Counter)

This function is to set and display calculated unit for actual length, liquid, position, etc. It is called "prescale value" for measured length, liquid, or position, etc per 1 pulse. For example, when moving L, the desired length to be measured, and P, the number of pulses per 1 revolution of a rotary encoder, occurs, prescale value is L/P.

E.g.) Positioning control by counter and encoder

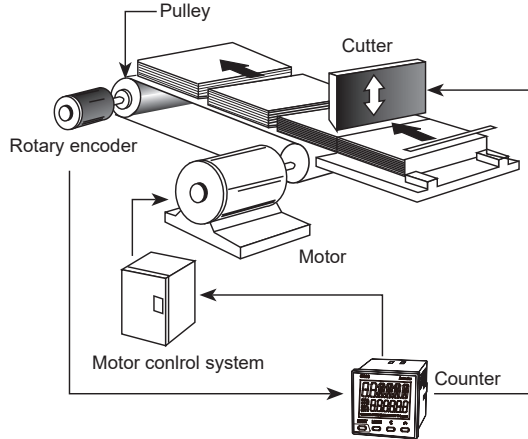

[Diameter (D) of pulley connected with encoder=22mm,  
the number of pulses by 1 rotation of encoder=1,000]

$$\begin{aligned} \bullet \text{Prescale value} &= \frac{\pi \times \text{Diameter (D) of pulley}}{\text{The number of pulses by 1 rotation of encoder}} \\ &= \frac{3.1416 \times 22}{1000} \\ &= 0.069\text{mm/pulse} \end{aligned}$$

Set decimal point [dP] as [- - - - . -], prescale decimal point [5CLdP] as [- - - . - -], prescale value [5CL] as [0.069] at function setting mode. It is available to control conveyor position by 0.1mm unit.

## ■ Start Point Function (Counter)

In case of counter operation, set the start value for counting at Start point [5tPrL].

- It is not available for  $d_n, d_{n-1}, d_{n-2}, d_{n-3}$  input mode.
- When pressing the RESET key, PV is reset as the start point value.
- In case of  $C, r, P, Q$  output mode, it counts up and PV starts from the start point value.

# CX Series

## ■ Timer mode

### ● Changing SV mode

When input signal is ON during changing SV, it operates counting and output control.

It is available to set SV as '0' and the dedicated output for SV '0' occurs.

There are output mode which cannot set SV as '0'. (the setting value display component flashes three times when SV is set as '0')

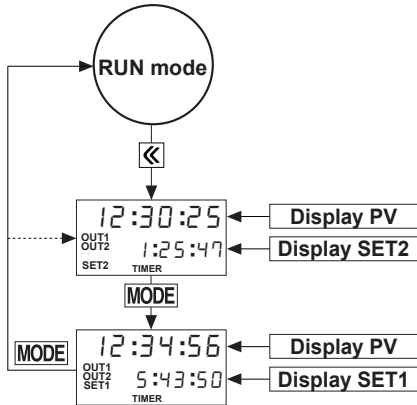

Press the key to enter changing SV mode in RUN mode.

When entering changing SV mode, the counting value display component displays the current value and the setting value display component displays SV.

After setting SV at each parameter, press the **MODE** key to save SV and it moves next parameter setting or returns to RUN mode.

### ● Function setting mode

※1: In case of free voltage input model (CX6□□□□F), these parameters do not appear due to fixed setting.

※2: This parameter is for the voltage input(PNP)/no-voltage input(NPN) selectable model (CX6□□□□).

※: When changing the setting of shaded parameters, all output turn OFF.

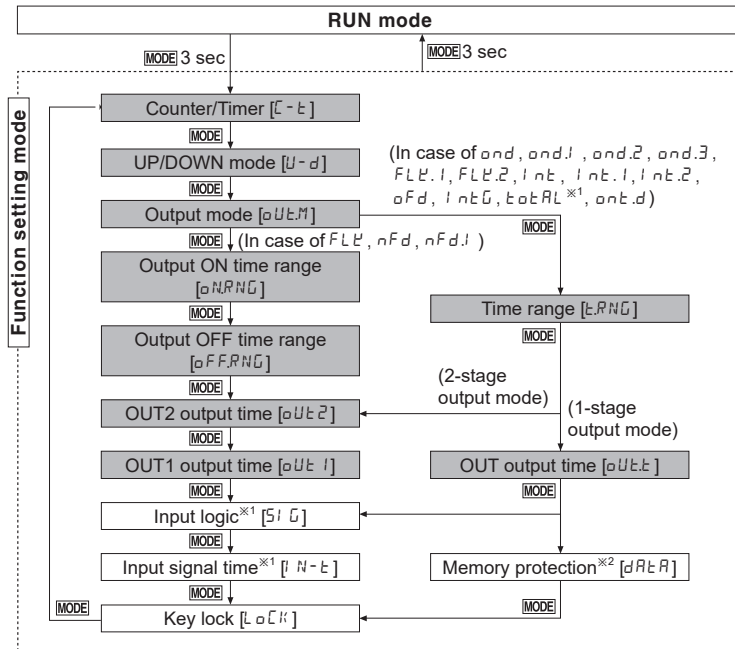

-Hold the **MODE** key over 3 sec in RUN mode and it enters function setting mode.

-Hold the **MODE** key over 3 sec in function setting mode and it returns to RUN mode.



# LCD Display Counter/Timer

## ● Switching display of the setting value display component

Select the display value at the setting value display component.

Depends on output mode, there are manual display switching and auto display switching.

-Manual display switching

1) In case of 2-stage setting model (CX6□-2P□□) and *oNd*, *oNd.1*, *oNd.2*, *oNd.3* output mode, it is available.

2) In run mode, whenever pressing the **MODE** key, the setting value display component displays SET1, SET2 SV in turn.

In case of 1-stage setting model (CX6□-1P□□), it is not available.

-Auto display switching

1) When output mode is *FLk*, *NFd*, *NFd.1* for 1-stage or 2-stage setting model (CX6□-1/2P□□) and *!Nt.2* mode for 2-stage setting model (CX6□-2P□□), the setting value display component automatically displays the set times depends on the operation status.

## ● RESET

-In RUN mode, function setting mode, press the **RESET** key to reset the current value and the output is also reset.

## ● Display type of the setting value display component by output mode

-In case of 2-stage setting model (CX6□-2P□□) and *oNd*, *oNd.1*, *oNd.2*, *oNd.3*, *!Nt.2* output mode, there are SET1 and SET2 setting.

It displays the each SV and the SET1, SET2 indicator turns ON when displaying or setting the each SV.

-In case of 1-stage setting model (CX6□-1P□□), SET is available and there is one setting value.

-In case of 1-stage setting model (CX6□-1P□□), *!Nt.2* output mode is not available.

-*FLk* output mode has *t.oFF*, *t.oN* setting values. In case of 2-stage setting model (CX6□-2P□□) and 1-stage setting model (CX6□-1P□□), each SET2, SET display is available.

(*t.oFF*, *t.oN* setting value is for OUT2 output. It displays SET2 or SET.)

-The other output modes display SET2 or SET and have one setting value.

(only for 1-stage setting model (CX6□-1P□□))

## ● Zero blanking display

PV is displayed with zero blanking for the highest unit.

E.g.)When time range is 99m59.99s and PV is 00m04.05s, zero blanking is applied to minute which is the highest unit.

At the below digits of decimal point, it is not applied.

It displays as "0:04.05".

# CX Series

## Parameter Setting (Timer)

(MODE) key: moves parameters, (F) key: changes parameter setting value

Parameter	Parameter setting value
Counter/Timer [C-t]	COUNT ↔ t1 nE ※[COUNT: Counter t1 nE: Timer
Up/Down mode [U-d]	UP ↔ dn ※UP: Time progresses from '0' to the setting time. dn: Time progresses from the setting time to '0'.
Output mode [OUT.M]	ond → ond.1 → ond.2 → ond.3 → FLk → FLk.1 → FLk.2 → Int → Int.d ← totAL *1 ← IntG ← nFd.1 ← nFd ← oFd ← Int.2 *2 ← Int.1
Time range [t.RNG] *3	999.999 → 9999.99 → 99999.9 → 999999 → 99:59.99 → 999:59.9
output ON TIME range [o.NRNG] *4	99999.9 → 9999:59 → 99:59:59 → 999999 → 99999.9 → 9999:59
output OFF TIME range [o.FFRNG] *4	99999.9 → 9999:59 → 99:59:59 → 999999 → 99999.9 → 9999:59
OUT 2 output time *5 [OUT.2]	※Set one-shot output time of OUT 2. ※Setting range: 00.01 to 99.99 sec, Hold ※When number of tens digit is flashing, press the (F) key once and Hold appears.
OUT 1 output time *5 [OUT.1]	※Set one-shot output time of OUT 1. ※Setting range: 00.01 to 99.99 sec, Hold ※When number of tens digit is flashing, press the (F) key once and Hold appears.
OUT output time *5 [OUT.t]	※Setting range: 00.01 to 99.99 sec, Hold ※When number of tens digit is flashing, press the (F) key once and Hold appears.
Input logic *6 [SIG]	nPP: No-voltage input, PnP: Voltage input
Input signal time *6 [IN.t]	t ↔ 20, unit: ms ※Set min. width of INA, INHIBIT, RESET, TOTAL RESET signal
Memory protection [dRAR]	CLR ↔ rEC ※CLR: Resets the counting value when power OFF. rEC: Maintains the counting value when power OFF. (memory protection)
Key lock [LOCK]	LoFF → LoC.1 → LoC.3 ← LoC.2 ※LoFF: Unlock keys, key lock indicator turns OFF LoC.1: Locks (RESET) key, key lock indicator turns ON LoC.2: Locks (F), (F) keys, key lock indicator turns ON LoC.3: Locks (RESET), (F), (F) keys, key lock indicator turns ON

※1: This is for the voltage input (PNP)/no-voltage input (NPN) selectable model (CX6□-□□).

※2: Int.2 mode is available only for 2-stage setting model (CX6□-2P□□).

※3: When output mode is ONd, ONd1, ONd2, ONd3, FLk1, FLk2, INT, INT1, INT2, OFD, INTG, TOTAL, ONtD, set time range [t.RNG].

※4: When output mode is FLk, NFD, NFD.1, set output ON TIME range [o.NRNG] and output OFF TIME range [o.FFRNG].

※5: In case of 1-stage setting model (CX6□-1P□□), oUT.1 output time does not appear.

oUT.2 output time is displayed as oUT.t.

※6: In case of free voltage input model (CX6□-□□F), this parameter does not appear due to fixed setting.

# LCD Display Counter/Timer

## Output Operation Mode (Timer)



Output mode	Time chart	Operation
OND [OND]	<p>Signal On Delay (Power RESET)</p>	<ol style="list-style-type: none"> <li>1)Time starts when INA signal turns ON.</li> <li>2)When INA signal turns OFF, time resets.</li> <li>3)When INA signal is ON : Power ON Time Start is operated. RESET OFF Time Start is operated.</li> <li>4)Control output operates as retained (Hold) or one-shot output.</li> </ol>
OND.1 [OND.1]	<p>Signal On Delay 1 (Power RESET)</p>	<ol style="list-style-type: none"> <li>1)Time starts when INA signal turns ON.</li> <li>2)When INA signal is ON : Power ON Time Start is operated. RESET OFF Time Start is operated.</li> <li>3)Control output operates as retained (Hold) or one-shot output.</li> <li>4)Only first INA input signal is valid in case INA input signal is repeatedly applied.</li> </ol>
OND.2 [OND.2]	<p>Power On Delay 2 (Power Hold)</p>	<ol style="list-style-type: none"> <li>1)Power ON Time Start (there is no INA function)</li> <li>2)RESET ON: Time RESET RESET ON→OFF: Time Start</li> <li>3)Control output operates as retained (Hold) or one-shot output.</li> <li>4)It memorizes display value at the moment of power OFF.</li> </ol>
OND.3 [OND.3]	<p>Power On Delay 3 (Power Hold/RESET)</p>	<ol style="list-style-type: none"> <li>1)Power ON Time Start (there is no INA function)</li> <li>2)RESET ON: Time RESET RESET ON→OFF: Time Start</li> <li>3)Control output operates as retained (Hold) or one-shot output.</li> <li>4)If time reached setting time at the moment of power ON, it is automatically reset.</li> </ol>

※Power RESET: There is no memory protection. (resets the display value when power is off)

※Power Hold: There is memory protection.

(memorizes the display value at the moment of power off, indicates the memorized display value when power is resupplied.)

# CX Series

## Output Operation Mode (Timer)

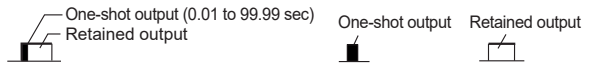

Output mode	Time chart	Operation
FLK [FLK]	<p>Flicker (Power RESET)</p>	<p><b>Operation</b></p> <ol style="list-style-type: none"> <li>1)Time starts when INA signal turns ON.</li> <li>2)When INA signal is ON : Power ON Time Start is operated. RESET OFF Time Start is operated.</li> <li>3)Control output operates as retained output, output turns off for the T.off time and turns on for the T.on time and turns on for the T.on time repeatedly. <math>T_a + T_b = T.off</math></li> <li>4)The T.on time and T.off time must be set individually.</li> <li>5)In case of using the contact output, min. setting time must be set over 100ms.</li> </ol>
	<p>Flicker 1 (Power Reset)</p> <p><b>Retained (Hold) output</b></p>	<ol style="list-style-type: none"> <li>1)Time starts when INA signal turns ON.</li> <li>2)When INA signal is ON : Power ON Time Start is operated. RESET OFF Time Start is operated.</li> <li>3)Control output operates as retained (Hold) output.</li> <li>4)In case of using the contact output, min. setting time must be set over 100ms.</li> </ol>
FLK.1 [FLK.1]	<p><b>One-shot output</b></p>	<ol style="list-style-type: none"> <li>1)Time starts when INA signal turns ON.</li> <li>2)When INA signal is ON : Power ON Time Start is operated. RESET OFF Time Start is operated.</li> <li>3)Control output operates as one-shot output.</li> <li>4)In case of using the contact output, min. setting time must be set over 100ms.</li> </ol>

※Power RESET: There is no memory protection. (resets the display value when power is off)

※Power Hold: There is memory protection.

(memorizes the display value at the moment of power off, indicates the memorized display value when power is resupplied.)

# LCD Display Counter/Timer

## Output Operation Mode (Timer)

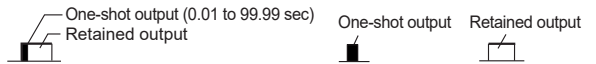

Output mode	Time chart	Operation
FLK.2 [FLK.2]	<p>Flicker 2 (Power Hold)</p> <p><b>Retained (Hold) output</b></p>	<ol style="list-style-type: none"> <li>Time starts when INA signal turns ON and the display value at the moment when power is off is memorized.</li> <li>When INA signal is ON : Power ON Time Start is operated. RESET OFF Time Start is operated.</li> <li>Control output operates as retained (Hold) output.</li> <li>Control output will be reversed when it reaches to setting time. (at the initial start, OUT2 control output is OFF).</li> <li>In case of using the contact output, min. setting time must be set over 100ms.</li> </ol>
	<p><b>One-shot output</b></p>	<ol style="list-style-type: none"> <li>Time starts when INA signal turns ON and the display value at the moment when power is off is memorized.</li> <li>When INA signal is ON : Power ON Time Start is operated. RESET OFF Time Start is operated.</li> <li>Control output operates as one-shot output.</li> <li>In case of using the contact output, min. setting time must be set over 100ms.</li> </ol>
INT [INT]	<p>Interval (Power RESET)</p>	<ol style="list-style-type: none"> <li>Control output turns ON and time starts when INA signal turns ON.</li> <li>When INA signal is OFF, time is reset.</li> <li>When INA signal is ON : Power ON Time Start is operated. RESET OFF Time Start is operated.</li> <li>When it reaches setting time, it is auto reset.</li> <li>Control output is ON when the time is progressing.</li> </ol>
	<p>Interval 1 (Power RESET)</p>	<ol style="list-style-type: none"> <li>Control output turns ON and time starts when INA signal turns ON.</li> <li>When INA signal is ON : Power ON Time Start is operated. RESET OFF Time Start is operated.</li> <li>When it reaches setting time, it is auto reset.</li> <li>Control output is ON when the time is progressing.</li> <li>Time is ignored while time is progressing.</li> </ol>

※Power RESET: There is no memory protection. (resets the display value when power is off)

※Power Hold: There is memory protection.

(memorizes the display value at the moment of power off, indicates the memorized display value when power is resupplied.)

# CX Series

## Output Operation Mode (Timer)

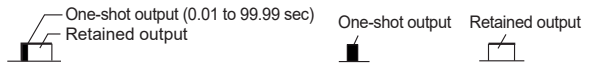

Output mode	Time chart	Operation
<b>INT.2</b> <i>[i n t . 2]</i>	<b>Interval 2 (Power RESET)</b> 	<p>1) Time starts when INA signal is ON, and resets when INA signal is OFF.</p> <p>2) INA signal is ON, OUT1 output is ON during T1 (HOLD) or t1.</p> <p>3) When it reaches setting time 1, display value resets and OUT2 output is ON during T2 (HOLD) or t2 output time.</p> <p>※ Output turns OFF when reaching the setting time even if one-shot is longer than setting time.</p> <p>T1: Setting time 1 T2: Setting time 2 t1: One-shot1 t2: One-shot2</p> <p>(1-stage SET model has no <i>i n t . 2</i> mode)</p>
<b>OFD</b> <i>[o f d]</i>	<b>Signal Off Delay (Power RESET)</b> 	<p>1) If INA is ON, control output remains ON. (except when power is off and reset is on)</p> <p>2) When INA signal is OFF, time processes. When it reaches setting time, indication value and control output are auto reset automatically.</p> <p>T: Setting time</p>
<b>NFD</b> <i>[n f d]</i>	<b>On-Off Delay (Power RESET)</b> 	<p>1) When INA input is ON, output is ON and time is progressing, then output is OFF after On_Delay time.</p> <p>2) When INA input is OFF, output is ON and time is progressing, then output is OFF after Off_Delay time.</p> <p>3) If INA input is OFF within On_Delay time, step 2 starts.</p> <p>4) If INA input is ON within Off_Delay time, step 1 starts.</p> <p>T1: On_Delay T2: Off_Delay</p>

※ Power RESET: There is no memory protection. (resets the display value when power is off)

※ Power Hold: There is memory protection.

(memorizes the display value at the moment of power off, indicates the memorized display value when power is resupplied.)

# LCD Display Counter/Timer

## Output Operation Mode (Timer)



Output mode	Time chart	Operation
NFD.1 [nFd.i]	On-Off Delay1 (Power RESET)	<p>1)When INA input turns ON, time progresses and output turns ON after On_Delay time.</p> <p>2)When INA input turns OFF, time progresses and output turns OFF after Off_Delay time.</p> <p>3)If INA input turns OFF within On_Delay time, output will turn ON and step 2 operate.</p> <p>4)If INA input turns ON within Off_Delay time, output will turn OFF and step 1 operate.</p>
INTG [i n t G]	Integration Time (Power RESET)	<p>1)Time is progressing while INA input is ON.</p> <p>2)Time progress stops while INA input is OFF.</p> <p>3)When it reaches the setting time, output is ON.</p>
TOTAL [t o t A L]	When memory protection setting is OFF	<p>1)Time starts when INA input is ON.</p> <p>2)When RESET signal is ON, the display value is reset.</p> <p>3)Time progress stops when INHIBIT signal is ON.</p> <p>4)The progressed time is reset when power OFF.</p>
	When memory protection setting is ON	<p>1)Time starts when INA input is ON.</p> <p>2)When RESET signal is ON, the display value is reset.</p> <p>3)Time progress stops when INHIBIT signal is ON.</p> <p>4)The progressed time at the moment of power OFF is memorized.</p>

※Power RESET: There is no memory protection. (resets the display value when power is off)

※Power Hold: There is memory protection.

(memorizes the display value at the moment of power off, indicates the memorized display value when power is resupplied.)

※When memory protection setting is OFF, it does not memorize the display value when power turns OFF.

(the display value is reset when power turns OFF)

※When memory protection setting is ON, it memorizes the display value when power turns OFF.

When re-supplying the power, it displays the memorized value.

# CX Series

## Output Operation Mode (Timer)

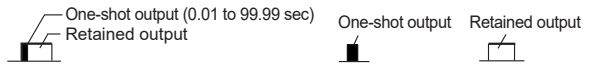

Output mode	Time chart	Operation
On Time Display [On.t.d]	<p><b>When memory protection setting is OFF</b></p>	<p>※ON time indicate mode of INA signal.</p> <ol style="list-style-type: none"> <li>1)Time reset start operates when INA signal turns ON.</li> <li>2)Time progress stops while INA signal is OFF.</li> <li>3)When INA signal is OFF, if INA input time is greater than the setting time, the display value flashes and the operation stops until RESET signal ON.※1</li> <li>4)When time progress stops and power turns OFF, the progressed time is reset.</li> </ol>
	<p><b>When memory protection setting is ON</b></p>	<p>※ON time indicate mode of INA signal.</p> <ol style="list-style-type: none"> <li>1)Time reset start operates when INA signal turns ON.</li> <li>2)Time progress stops while INA signal is OFF.</li> <li>3)When time progress stops and power turns OFF, the progressed time at the moment of power OFF is memorized.</li> </ol>

※1: For free voltage input model (CX6□□□F).

※Power RESET: There is no memory protection. (resets the display value when power is off)

※Power Hold: There is memory protection.

(memorizes the display value at the moment of power off, indicates the memorized display value when power is resupplied.)

※When memory protection setting is OFF, it does not memorize the display value when power turns OFF.

(the display value is reset when power turns OFF)

※When memory protection setting is ON, it memorizes the display value when power turns OFF.

When re-supplying the power, it displays the memorized value.



# LCD Display Counter/Timer

## ■ Timer '0' Time Setting

### ◎ Available output operation mode to set '0' time setting

*ond, ond.1, ond.2, ond.3, nFd, nFd.1*

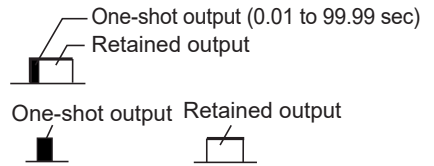

### ◎ Operation according to output mode (at 0 time setting)

#### 1) OND (Signal ON Delay) mode [*ond*]

##### ● Set '0' for setting time1 .

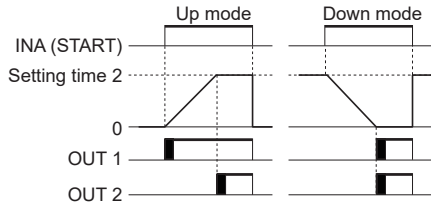

##### ● Set '0' for setting time2 .

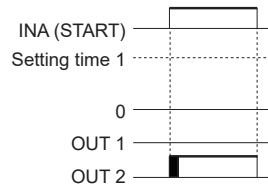

#### 2) OND.1 (Signal ON Delay 1) mode [*ond.1*]

##### ● Set '0' for setting time1 .

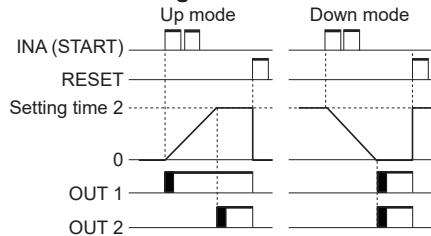

##### ● Set '0' for setting time2 .



#### 3) OND.2 (Power ON Delay 2) mode [*ond.2*]

##### ● Set '0' for setting time1 .

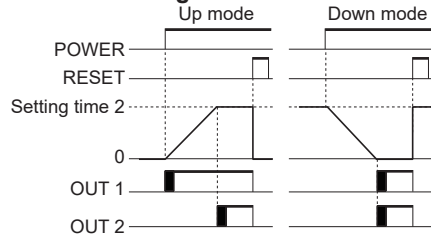

##### ● Set '0' for setting time2 .

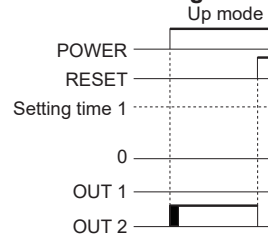

#### 4) OND.3 (Power ON Delay 3) mode [*ond.3*]

##### ● Set '0' for setting time1 .

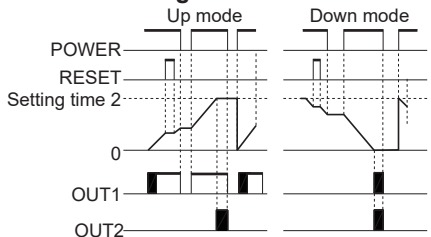

##### ● Set '0' for setting time2 .

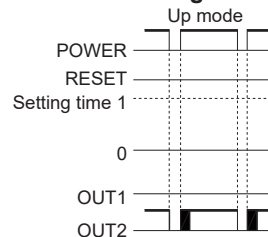

#### 5) NFD (ON-OFF Delay) mode [*nFd*]

##### ● Set '0' for Off\_Delay setting time.

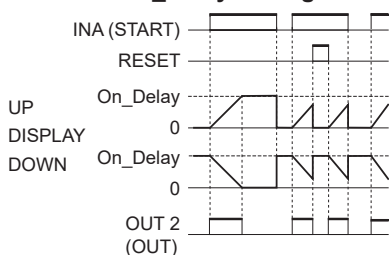

##### ● Set '0' for On\_Delay setting time.

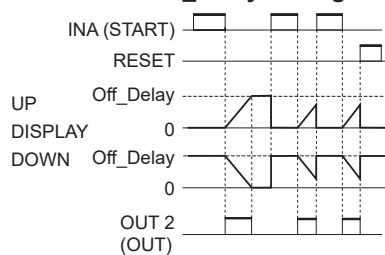

# CX Series

## 6) NFD.1 (ON-OFF Delay1) mode [ $n^{F d. 1}$ ]

- Set '0' for Off\_Delay setting time.

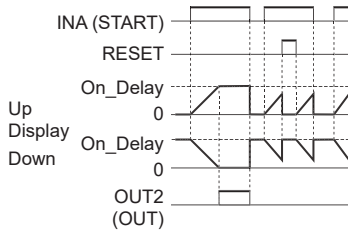

- Set '0' for On\_Delay setting time.

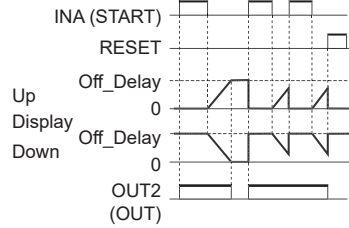

### Ⓢ When SET1 is greater than SET2

In case of OND[ $o_{nd}$ ], OND.1[ $o_{nd.1}$ ], OND.2[ $o_{nd.2}$ ], or OND.3[ $o_{nd.3}$ ] output mode,

- UP mode: When timer setting value 1 (SET1) is greater than setting value 2 (SET2),  $o_{ut.1}$  output does not turn ON.
- DOWN mode: When timer setting value 1 (SET1) is greater than setting value 2 (SET2),  $o_{ut.1}$  output does not turn ON.  
When timer setting value 1 (SET1) and setting value 2 (SET2) are same,  $o_{ut.1}$  output turns ON when applied the start signal.

## ■ Factory Default

Parameter	Factory default	
	CX6□□□	CX6□□□F
INM	Ud-C	Ud-R
oUt.M	F	F
CPS	30	—
oUt.2 (oUt.t <sup>※1</sup> )	Hold (fixed)	Hold (fixed)
oUt.1 <sup>※1</sup>	00.10	00.10
dP	-----	-----
rESEt	20ms	—
SiG	nPn	—
SCLDP	- - - - -	- - - - -
SCt	100000	100000
t.o.t.RL <sup>※2</sup>	oFF	—
StARRt	000000	000000
dARtR	CLr	CLr
U-d	UP	UP
oUt.M	oNd	oNd
oUt.2 (oUt.t <sup>※1</sup> )	Hold	Hold
oUt.1 <sup>※1</sup>	00.10	00.10
t.RNG	999999s	999999s
SiG <sup>※2</sup>	nPn	—
IN-t	20ms	—
LoCk	LoFF	LoFF
SET1	1000	1000
SET2	5000	5000

※1: For 1-stage setting model (CX6□-1P□□),  $o_{ut.1}$  does not appear.

The output time of  $o_{ut.2}$  is displayed as  $o_{ut.t}$ .

※2: This is for the voltage input (PNP)/no-voltage input (NPN) selectable model (CX6□-□□).

## ■ Cautions during Use

- Follow instructions in 'Cautions during Use'. Otherwise, it may cause unexpected accidents.
- In case of 24-48VDC, 24VAC model, power supply should be insulated and limited voltage/current or Class 2, SELV power supply device.
- Use the product, 0.1 sec after supplying power.
- When supplying or turning off the power, use a switch or etc. to avoid chattering.
- Install a power switch or circuit breaker in the easily accessible place for supplying or disconnecting the power.
- Keep away from high voltage lines or power lines to prevent inductive noise.
- In case installing power line and input signal line closely, use line filter or varistor at power line and shielded wire at input signal line.  
Do not use near the equipment which generates strong magnetic force or high frequency noise.
- This unit may be used in the following environments.
  - ① Indoors (in the environment condition rated in 'Specifications')
  - ② Altitude max. 2,000m
  - ③ Pollution degree 2
  - ④ Installation category II

### ООО "РусАвтоматизация"

454010 г. Челябинск, ул. Гагарина 5, оф. 507

тел. 8-800-775-09-57 (звонок бесплатный), +7(351)799-54-26, тел./факс +7(351)211-64-57

info@rusautomation.ru; русавтоматизация.рф; www.rusautomation.ru