



Operating instructions
Safety Rope Emergency Stop Switches

UK

ZB0052 / ZB0053
ZB0072 / ZB0073

7390878 / 04 06 / 2020

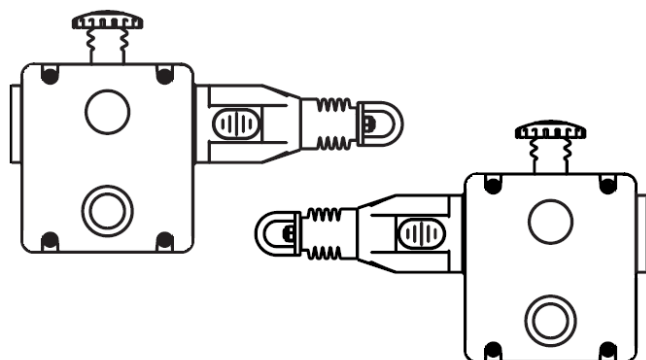

Contents

- 1 Safety instructions3
- 2 Installation / set-up4
 - 2.1 Applications.....4
 - 2.2 Function and electrical connection.....4
- 3 Operating and display elements5
- 4 Installation6
- 5 Function.....8
 - 5.1 Maintenance requirement8
- 6 Electrical connection.....9
- 7 Safety characteristics12
- 8 Technical data13
- 9 Scale drawing14
- 10 Accessories15
- 11 Standards16
- 12 Approvals / certificates.....16

1 Safety instructions

Follow the operating instructions.

Non-observance of the instructions, operation which is not in accordance with use as prescribed below, wrong installation or incorrect handling can affect the safety of operators and machinery.

For installation and prescribed use of the product the notes in the operating instructions must be carefully observed and the applicable technical standards relevant for the application have to be considered.

Failure to observe instructions or standards, especially any tampering with and/or modification to the product, will void any manufacturer's liability.

The unit must be installed, connected and put into operation by a qualified electrician trained in safety technology.

After installation the system must be subjected to a complete function check.

Disconnect the device externally before handling it. Also disconnect any independently supplied relay load circuits.

For installation the requirements according to EN 60204-1 must be observed.

In case of malfunction of the unit please contact the manufacturer. Tampering with the device can seriously affect the safety of operators and machinery. It is not permitted and leads to the exclusion of any liability and warranty claims.

2 Installation / set-up

2.1 Applications

The safety rope emergency stop switch is used to provide safety-related switching statuses where large danger areas have to be secured and housings or covers are not possible.

Typical applications are conveyor systems and rotating machines and large danger areas.

The safety rope emergency stop switch meets the requirements of EN ISO 13850, IEC / EN 60947-5-1 and IEC / EN 60947-5-5.

The safety rope emergency stop switch can be used in applications up to performance level e according to EN ISO 13849-1.

2.2 Function and electrical connection

Make careful note of all information in the operating instructions of the safety rope emergency stop switch. This document provides all required instructions concerning installation, mounting, operation and maintenance.

Important note



The products described here are designed to be components of a safety-oriented machine or control system. A complete safety-related system normally includes sensors, evaluation units, signaling components and concepts for safe switch-off. It is the responsibility of each manufacturer of a machine or installation to ensure a correct functioning of the whole system.

The manufacturer of the safety rope emergency stop switch, his subsidiaries and affiliates are not in a position to ensure all of the characteristics of a machine or product which was not designed by him.

The manufacturer accepts no liability for any recommendation that may be implied or stated here. The warranty contained in the contract of sale is the sole warranty. Any statements contained herein do not create new warranties or modify existing ones.

Compliance with the description of the operating instructions of the safety rope emergency stop switch is mandatory!

3 Operating and display elements

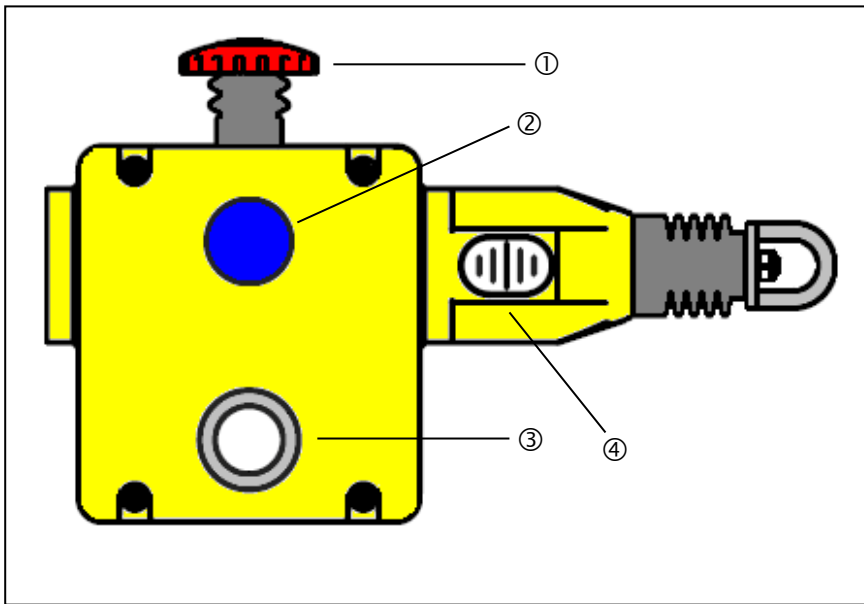

- 1: red E-stop
- 2: blue reset button
- 3: dual LED
- 4: rope tension indicator

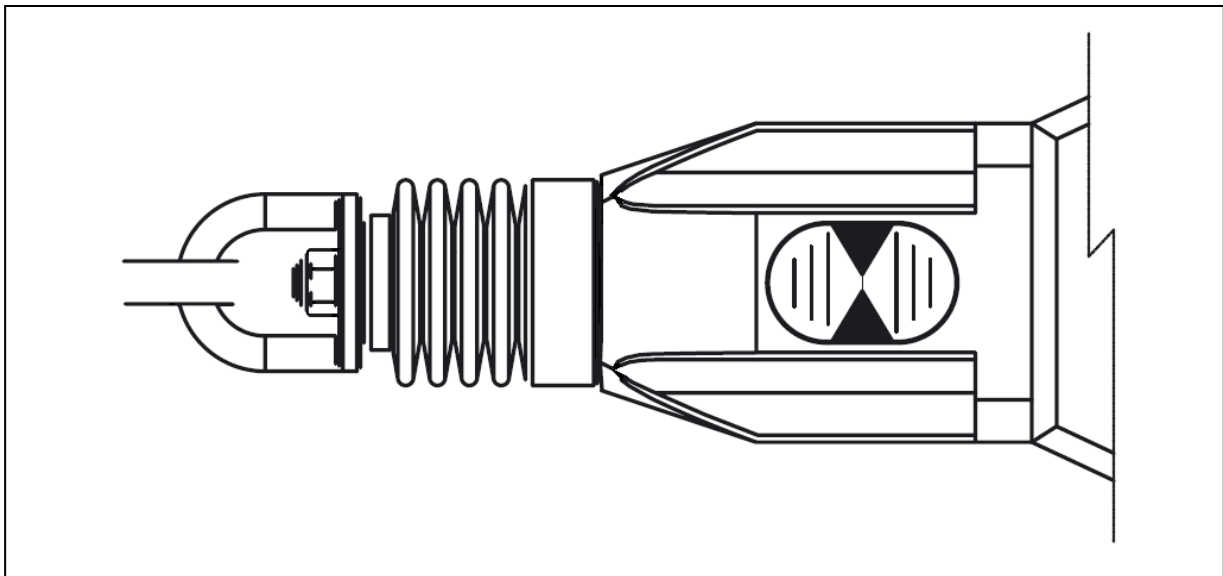

Rope tension indicator: Indicator shown with steel rope properly adjusted

4 Installation

Installation must be carried out by authorized personnel. The safety rope emergency stop switch is mounted using four M5 screws. The tightening torque for the fixing screws is 4 Nm. The tightening torque for the cover screws, the cable glands and cable seals are 1.5 Nm to ensure protection rating IP 67. Only use seals of the correct size for the cable entry and the external diameter of the cable.

The maximum vertical pull force on the rope pull is 130N until activation, the max. travel 300mm. Enough space has to be provided so that the required actuation travel can be reached.

Eye bolts have to be installed between the switches across the whole length of the rope at a distance of min. 2.5m to max. 3m. If this cannot be achieved due to conveyor layout fixings, then a reduction is possible (e.g. every 2m) providing that appropriate installation checks are made at each end and the middle of the rope system. These checks must ensure that the system operates when the rope is pulled in any direction and the parameters to trip the system are satisfied.

The first eyebolt must be mounted at a distance of max. 500mm of the switch eye bolt or the tension spring (if it is used). It is important to note that the first 500mm cannot be used as part of the active protected area (E-stop triggering).

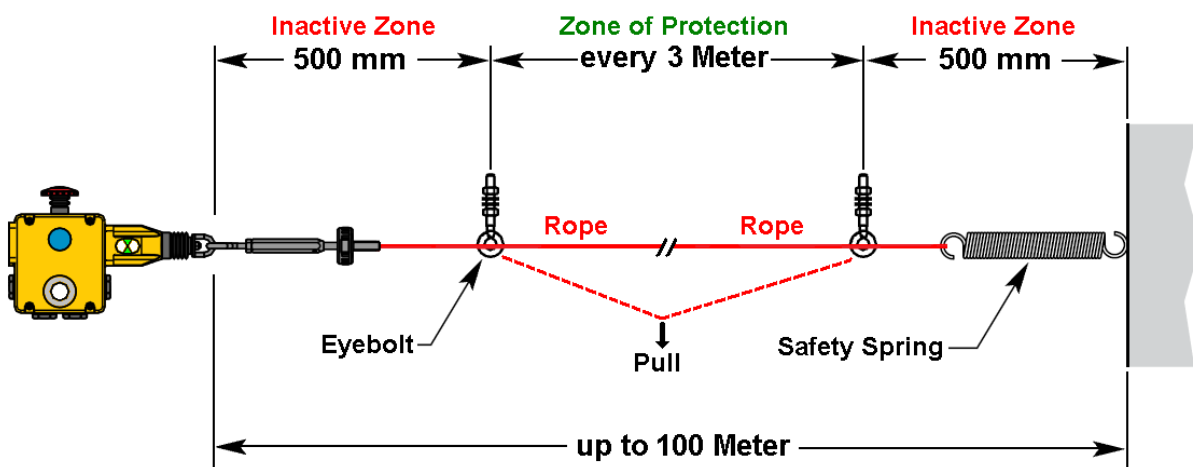
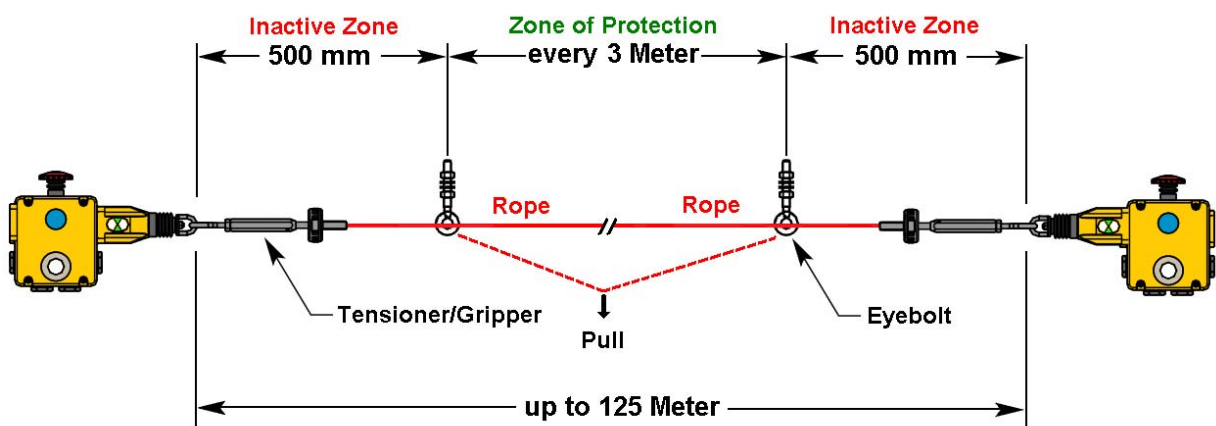

Installation of the components

The tension of the rope is obtained by rope tensioner systems. After the installation the tension must be set to the middle position which is indicated by green arrows in the transparent window of the individual switches. Verify the function of all switches and the control circuits by pulling on various spots on the rope in the active protected area and then resetting the individual switches by pressing the blue reset button.

Ensure each time that the switches clip into place and have to be reset manually by pressing the blue button. If necessary, increase the rope tension until the tests along the active length of the area are satisfactory.

The switches are equipped with a red, mushroom-shaped E-stop button. Check the individual emergency stop switches and reset them to ensure proper functioning of the control circuits.

The typical operating conditions for a successful operation of the safety rope emergency stop system are:

max. 75N pull force and max. 150mm bending of the rope between the eye bolts for rope support.

Rope pull systems with **single** direction safety rope emergency stop switches are influenced by fluctuations of the ambient temperature!

To ensure proper function of the rope pull system it is mandatory to take into account the dependence on the temperature when fixing the rope length and distance of the eye bolts (every 3m).

+ 25°C							
+ 22°C							
+ 20°C							
+ 15°C							
+ 10°C							
+ 7,5°C							
+ 5°C							
+ 3°C							
Installation Temperature [°C]							
- 3°C							
- 5°C							
- 7,5°C							
- 10°C							
- 15°C							
- 20°C							
- 22°C							
- 25°C							
Rope Length	15m	30m	50m	60m	75m	100m	126m

Installation Temperature in [°C] ± X [°C] = max. allowed rope length in [m]

	Not OK
	OK

5 Function

Pulling the tensioned rope, rope breakage or impact on the E-stop cause activation of the switching function of the safety rope emergency stop switch.

There is a window on the switch via which the correct rope tension can be monitored during setting and maintenance. Setting, troubleshooting and maintenance are made much easier.

After activation of the E-stop function a latching mechanism maintains the E-stop command until it is unlocked manually by pressing the blue reset button. Before resetting the E-stop signal the cause of the activation has to be determined. Reset is only possible with correct rope tension (position indication in middle position).

The max. rope length also depends on the change of the ambient temperature.

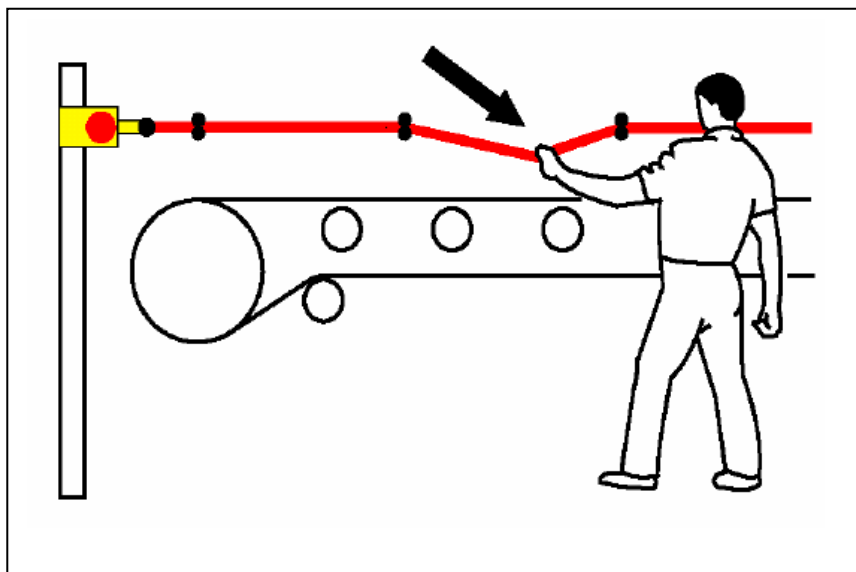

Function of the safety rope emergency stop switch

5.1 Maintenance requirement

Monthly:

Check proper functioning of the system at various spots along the rope length. Check the setting of the nominal rope tension and re-adjust it, if necessary.

Every six months:

Separate the voltage supply and remove the cover. Make sure that the screws are tight and check them for signs of penetrated moisture.



Damaged or faulty devices are to be replaced! Repair is not permissible.

6 Electrical connection

Wiring is only possible if the device is disconnected from power.

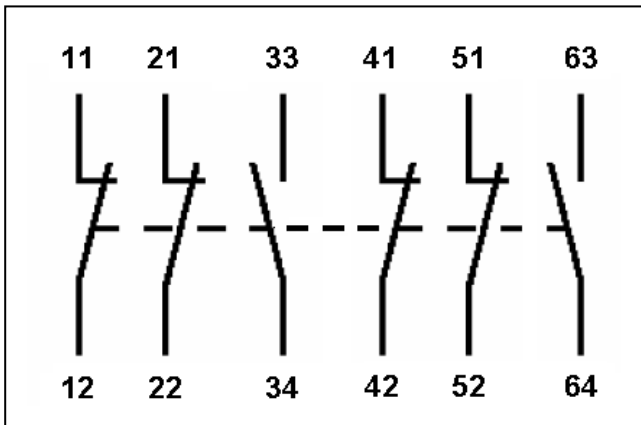

Contact arrangement

	0 mm	3.5 mm	14.5 mm	17.0 mm
4 NC + 2 NO	Rope slack	Tension range		Rope pulled
11/12				
21/22				
33/34				
41/42				
51/52				
63/64				

contact open contact closed

Contact travels safety rope emergency stop switch

24 V DC LED:

+ 24 V DC on terminal 1 -> LED display flashing red

+ 24 V DC on terminal 3 -> LED display permanently green

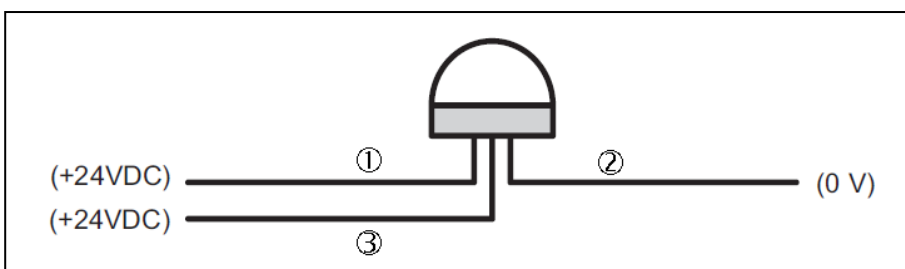

Installation sample:

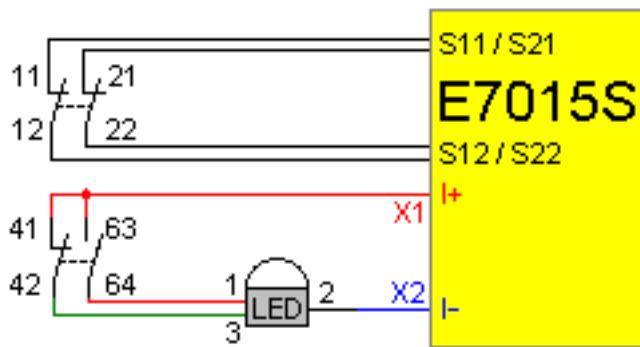

Programming sample:

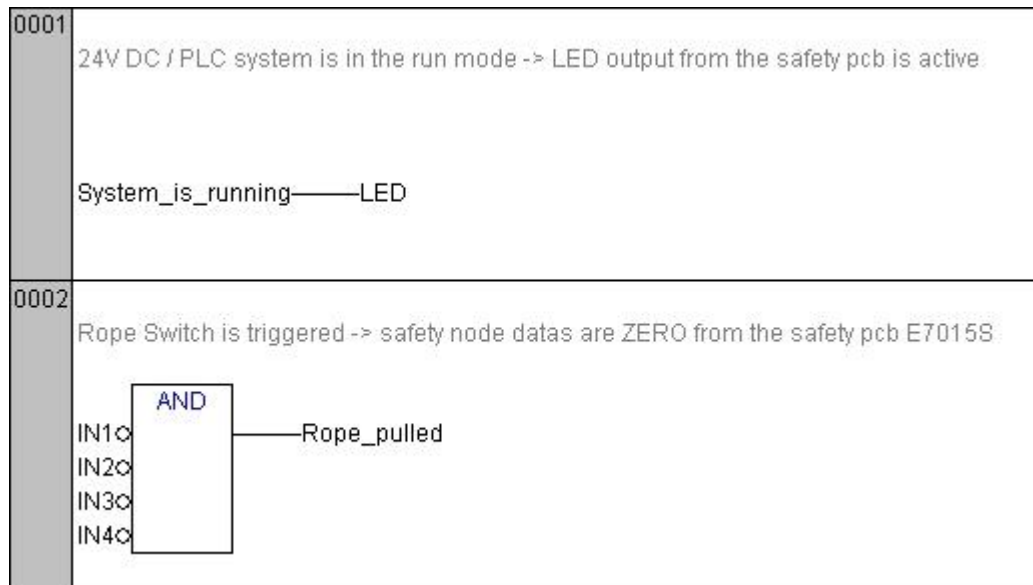

Data bits:

Data bit	D3	D2	D1	D0
In/Out	SI-2	SI-2	SI-1	SI-1/O-1

Activated input channel	Bit sequence D3-D0
SI-1	XX00
SI-2	00XX
SI-1 and SI-2	0000
none	XXXX
Activated alarm outputs	Bit sequence D3-D0
O-1	XXX1

X= random

110 V AC LED:

110 V AC on terminal 1 (red) -> LED display flashing red

110 V AC on terminal 3(green) -> LED display permanently green

0V on terminal 2 (black)

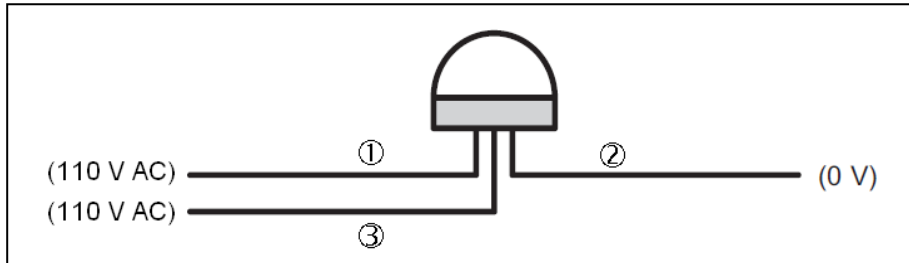

Installation sample:

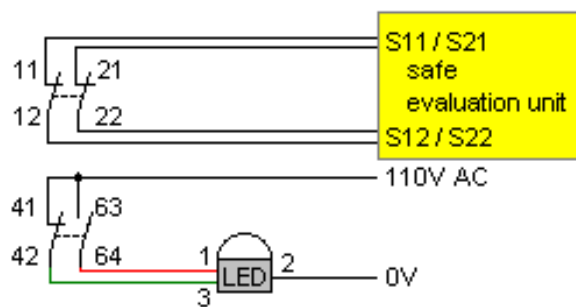

7 Safety characteristics

Characteristics	Value
B10 _d	1.5 • 10 ⁶ cycles at 100mA load
ISO 13849-1	Up to PLe depending upon system architecture
EN 62061	Up to SIL3 depending upon system architecture
Annual Usage	8 cycle per hour/24hours per day/365 days MTTF _d 214 years

The safety rope switch may be used as part of the safety related control system to perform the emergency stop function in accordance with EN 13850.

For the PFD-/PFH values and the MTTF_d values of the other components see the respective documentation.

Explanation of the abbreviations:

PL	Performance Level	Capability of safety-related parts to perform a safety function at predictable conditions to fulfill the expected risk reduction.
SIL	Safety Integrity Level	Safety Integrity Level SIL 1-4 to IEC 62061. The higher the SIL the lower the probability that a safety function will fail.
B10 _d		Number of cycles, up to 10% of the components with dangerous failure.
MTTF _d	Mean Time To Dangerous Failure	

8 Technical data

Electrical design	
Safety contacts	4 NC
Auxiliary contact	2 NO
Type of contact	snap-action contacts
Contact material	silver
Switching capacity	AC: 240 V/3 A, 120 V/6 A, inductive DC: 24 V/2.5 A, inductive
Max. switching voltage/switching capacity	240 V/720 VA
Minimum load	5 V, 5 mA DC
Thermal current	10 A
Rated Insulation voltage	500 V
Short-circuit / overload protection	external fuse 10A (FF)
Connection	terminal up to 2.5 mm ²
Mechanical design	
Fixing elements	4 x M5 screws
Mounting position	as required
Cable entry	4 x M20
Max. rope length	125 m
Activation force (on rope)	< 125 N
Tension force for operating position (axial)	130 N (between switches)
Switching contacts	to IEC / EN 60947-5-1
Mechanical life	> 1,000,000 activations
Function display	
Operation	LED green
Error	LED red, flashing
current load LED	15 mA
Ambient temperature	-25...80 °C
Protection rating	IP 67
Vibration resistance	10 - 500 Hz
Shock resistance	15g 11ms
Housing material	die-cast aluminum
Housing colour	yellow
Weight	1100 g

9 Scale drawing

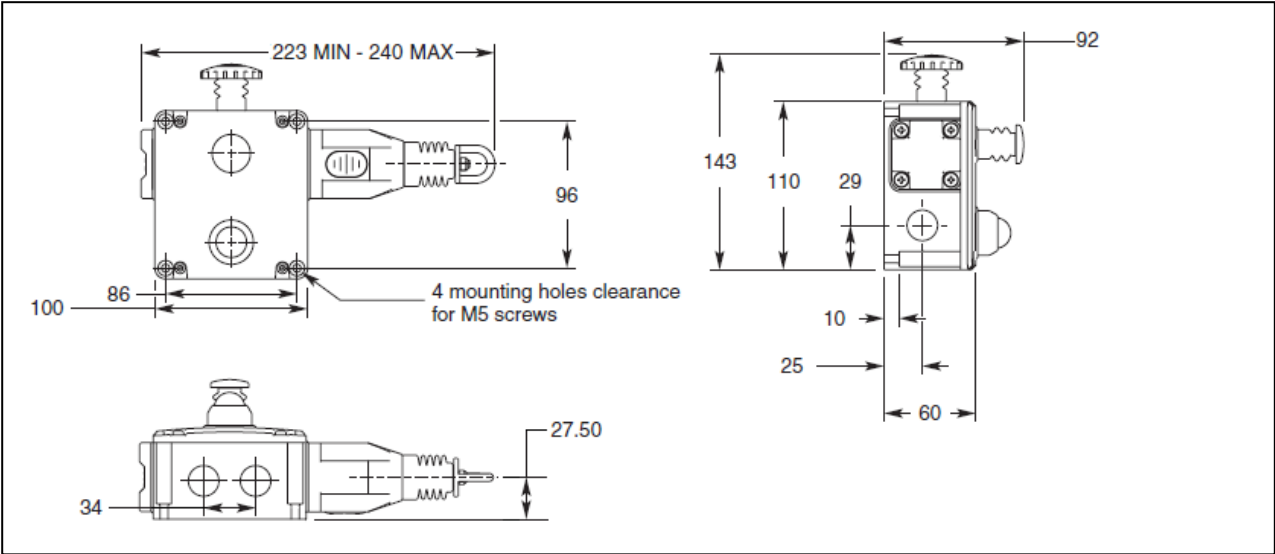

ZB0052 / ZB0072

Dimension in mm

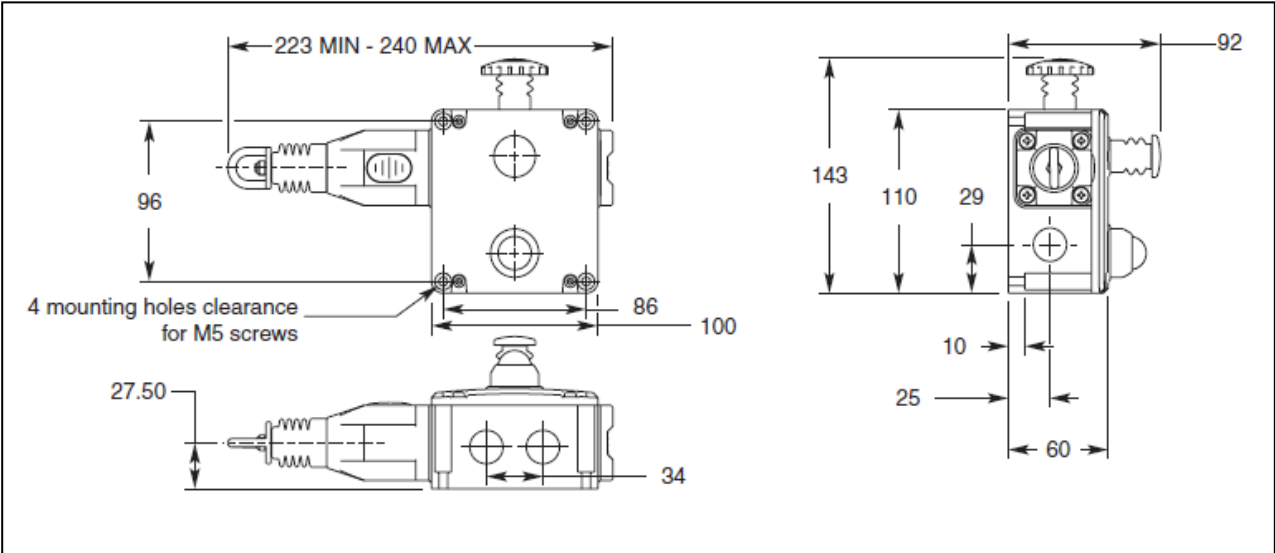

ZB0053 / ZB0073

Dimension in mm

10 Accessories

ZB0050: Safety rope e-stop switch with dual sided rope connection

ZB0051: Safety rope e-stop switch with dual sided rope connection, LED 24 V DC

ZB0071: Safety rope e-stop switch with dual sided rope connection, LED 110 V AC

ZB0054: Rope tensioner kit, stainless steel, rope length 5 m

ZB0055: Rope tensioner kit, stainless steel, rope length 10 m

ZB0056: Rope tensioner kit, stainless steel, rope length 20 m

ZB0057: Rope tensioner kit, stainless steel, rope length 50 m

ZB0058: Rope tensioner kit, stainless steel, rope length 80 m

ZB0059: Rope tensioner kit, stainless steel, rope length 100 m

ZB0060: Rope tensioner kit, stainless steel, rope length 126 m

ZB0061: Safety spring, stainless steel, 220 mm

ZB0062: Pulley

E7015S: Safe AS-i Safety at Work PCB

E11295: M12 adapter plug to metric M20, 4 poles

E21010: M20 x 1.5 cable gland

11 Standards

The following standards and directives have been applied:

- Machinery Directive 2006/42/EC
- EN ISO 13850: 2015
- EN 60947-5-1: 2017
- EN 60947-5-5: 1997 + A2: 2017
- EN 60204-1: 2018
- AS/NSZ 4024.1 - 2014
- UL 508

Information with regard to UL 508:

Type 1 Enclosures.

Use 16 - 12 AWG copper conductors, rated 90°C minimum.

Intended for same polarity use and one polymeric conduit connection.

Electrical Rating: A300 240V / AC 3A. (6,000 cycles)
120V / 60A. Making 6A. Breaking PF >0.38 (100,000 cycles)
240V / 10A. carry only.

Wire range: 16AWG - 12AWG Copper, Torque 7lb/in (0.8Nm)

LED powered by LVLC or Class 2 only.

Earth bonding terminal inside enclosure if required.

Hints for AS4024.3610 conveyors

Information with regard to AS4024.1-2014:

- 1) Perpendicular force to operate the switches midway between eyebolt
Supports: Check <70N. rope deflection <300mm
- 2) Axial force - direct along rope axis: <230N (Typical 125N).

Typical parameters for successful operation of a system is less than 70N pulling force with less than 150mm deflection of rope between eyebolt supports. This can normally be achieved with rope switches set to the mid position between the green arrows in the viewing window. If required, depending upon the necessary checks along the active length of coverage, the tension can be increased further beyond the mid position to ensure a tripping pulling force of less than 70N.

12 Approvals / certificates

- EC declaration of conformity
- UL (cULus)
- AS/NSZ 4024.1