



Operating instructions
Vibration transmitter

efector800
VTV12A

UK

80000575/00 04/2013

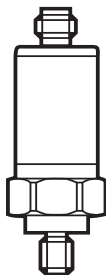

Symbols used

▶ Instructions



Important note

Non-compliance can result in malfunction or interference.

1 Safety instructions

- Please read the product description prior to set-up of the unit. Ensure that the product is suitable for your application without any restrictions.
- The unit complies with the relevant regulations and EU directives.
- Improper or non-intended use may lead to malfunctions of the unit or to unwanted effects in your application.
- That is why installation, electrical connection, set-up, operation and maintenance of the unit must only be carried out by qualified personnel authorised by the machine operator.
- Please adhere to the notes on safe use in hazardous areas: → operating instructions (Ex protection related part) for vibration sensors according to the EU directive 94/9/EC annex VIII (ATEX) group II, equipment category 3G / 3D.
- If no operating instructions (Ex protection related part) or EC declaration of conformity is supplied with this product in the language of the EU user country, these can be requested from your dealer (see delivery note) or manufacturer (see cover sheet / back).

2 Functions and features

The vibration transmitter detects the vibration in the system (measured / evaluated physical unit = vibration velocity). This is converted into an analogue signal at the current output.

3 Installation

- ▶ Mount only in a thick housing wall (e.g. transport thread).
 - ▶ Ensure that the signal direction is correct.
 - ▶ Ensure a safe vibration transmission and allow no elastic intermediate layers.
-
- ▶ Select either the 1/4"-28 UNF / M8 (2) or the 1/4"-28 UNF (3) threaded adapter and insert into the unit (1). Threaded adapters are supplied.
 - ▶ Tighten using a 3 mm Allen key. Tightening torque 8 Nm.
 - ▶ Drill and tap a hole at the mounting location:
 - M8 hole / depth min. 10 mm for threaded adapter 1/4"-28 UNF / M8.
 - Or 1/4"-UNF hole / depth min. 13 mm for threaded adapter 1/4"-28 UNF.

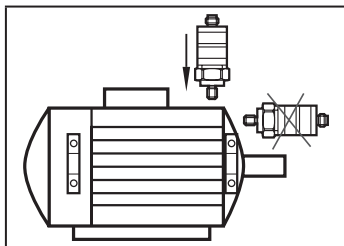

UK

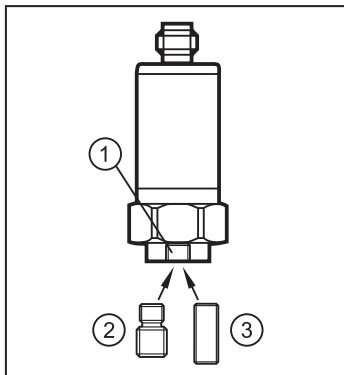

- ▶ Tighten the unit with a tightening torque of 8 Nm.

4 Electrical connection



The unit must be connected by a qualified electrician. The national and international regulations for the installation of electrical equipment must be adhered to.

M12			Pin 1: L+ (9.6...32 V DC) Pin 2: 4...20 mA
-----	--	--	---

4.1 Measuring range

V_{eff}	mm/s	0...25
I_{out}	mA	4...20
Response delay	s	0.5
Frequency range	Hz	10...1000

5 Scale drawing

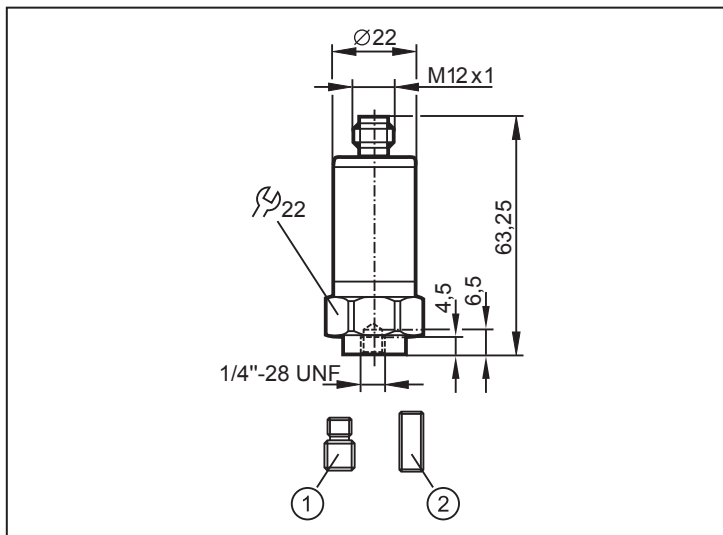

1: Threaded adapter 1/4"-28 UNF / M8

2: Threaded adapter 1/4"-28 UNF

Tightening torque 8 Nm

6 Maintenance, repair, disposal

The operation of the unit is maintenance-free. It is not possible to repair the unit. After use dispose of the unit in an environmentally friendly way in accordance with the applicable national regulations.

7 Technical data

Technical data and further information at www.ifm.com

UK