

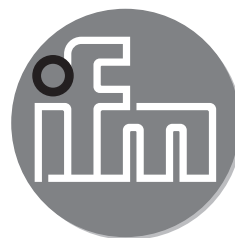

ifm electronic



Operating instructions
Vibration sensor

efector®
VKV021

UK

704575 / 02 08 / 2014

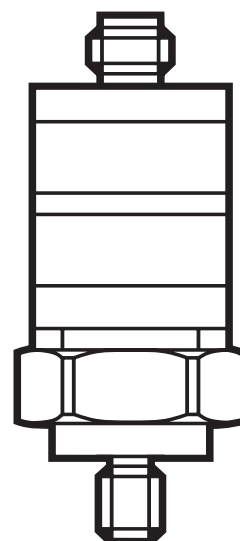

Contents

| | |
|--|---|
| 1 Safety instructions | 3 |
| 2 Functions and features | 4 |
| 3 Installation | 4 |
| 4 Electrical connection..... | 4 |
| 5 Settings..... | 4 |
| 5.1 Measuring range..... | 5 |
| 5.2 Switching output behaviour | 5 |
| 6 Operating and display elements | 6 |
| 7 Scale drawing | 7 |
| 8 Maintenance, repair, disposal..... | 7 |
| 9 Technical data..... | 7 |

Preliminary note

- An instruction is indicated by "▶":
Example: ▶ Check whether the unit operates correctly.



Important note

Non-compliance can result in malfunctions or interference.



Information

Supplementary note.

1 Safety instructions

- Please read the product description prior to set-up of the unit. Ensure that the product is suitable for your application without any restrictions.
- The unit conforms to the relevant regulations and EC directives.
- Improper or non-intended use may lead to malfunctions of the unit or to unwanted effects in your application.
- That is why installation, electrical connection, set-up, operation and maintenance of the unit must only be carried out by qualified personnel authorised by the machine operator.

2 Functions and features

The vibration sensor detects the vibration in the system (measured / evaluated physical unit = vibration velocity). This is converted into an analogue signal at the current output. The switching output behaviour is determined using the two setting rings.

3 Installation

- ▶ Mount only in a thick housing wall (e.g. transport thread).
- ▶ Ensure that the signal direction is correct.
- ▶ Ensure a safe vibration transmission and allow no elastic intermediate layers.
- ▶ Tighten the sensor with a tightening torque of 15 Nm.

4 Electrical connection

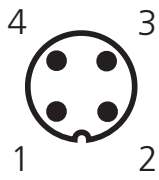
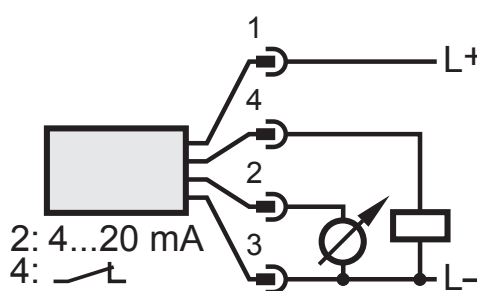

The unit must be connected by a qualified electrician. The national and international regulations for the installation of electrical equipment must be adhered to.

| | | | |
|-----|---|--|---|
| M12 |  |  | Pin 1: L+ |
| | | | Pin 2: 4...20 mA |
| | | | Pin 3: GND |
| | | | Pin 4: digital output (normally closed) |

5 Settings

RMS Set

Effective value of the switching threshold, defining the limit value of the vibration velocity.

Delay Set

Time in seconds during which the limit value must be effectively above the switching threshold (RMS Set) to activate the switching output (normally closed pin 4).

5.1 Measuring range

| | | |
|------------------|------|--------|
| V_{eff} | mm/s | 0...25 |
| I_{out} | mA | 4...20 |
| Response delay | s | 1...60 |

5.2 Switching output behaviour

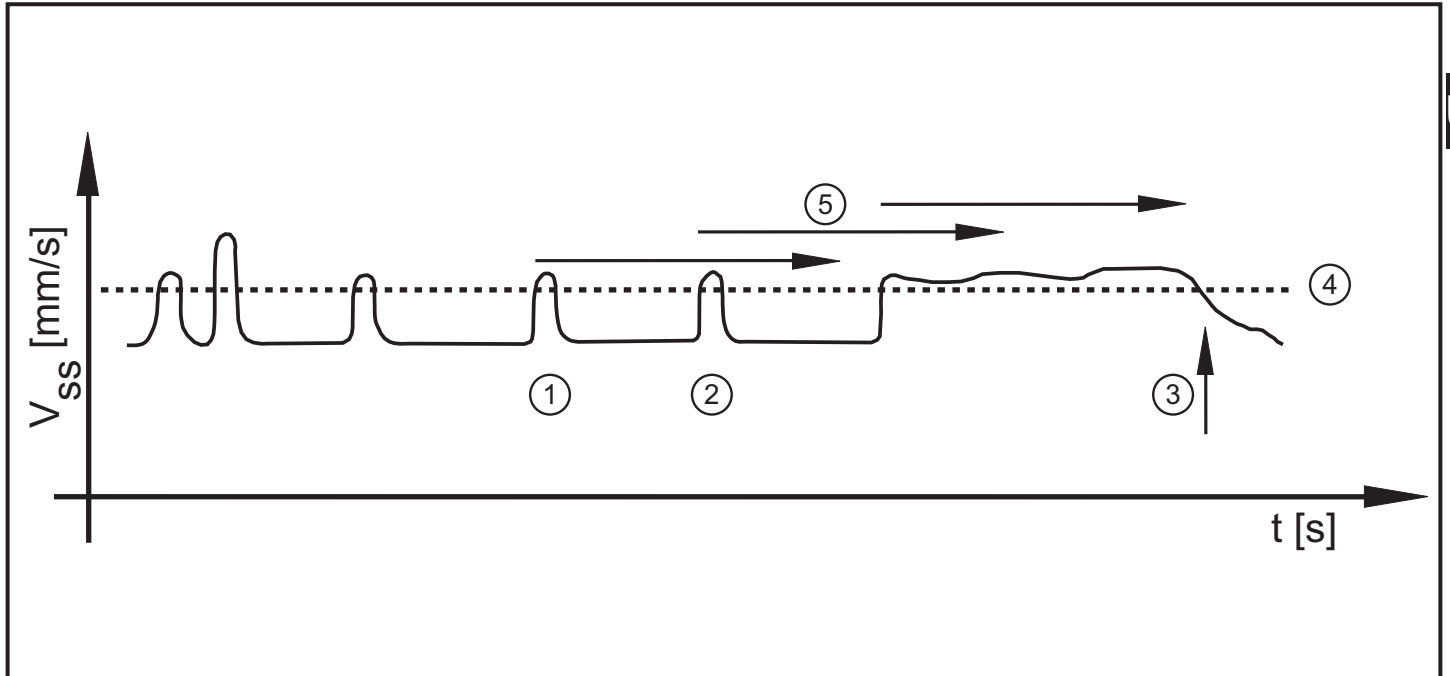

- 1: Time delay after the switching threshold has been exceeded
 - 2: Time delay after the switching threshold has been exceeded
 - 3: Switch-off
 - 4: Switching threshold
 - 5: Delay
- V_{ss} = vibration velocity
 t = time

Implementation of the time delays

The time delay starts when the defined switching threshold is exceeded (1) / (2). The time delay is cancelled when the value falls below the switching threshold (without switch-off). The switch-off is triggered when the switching threshold is exceeded during a full time delay (3).

6 Operating and display elements

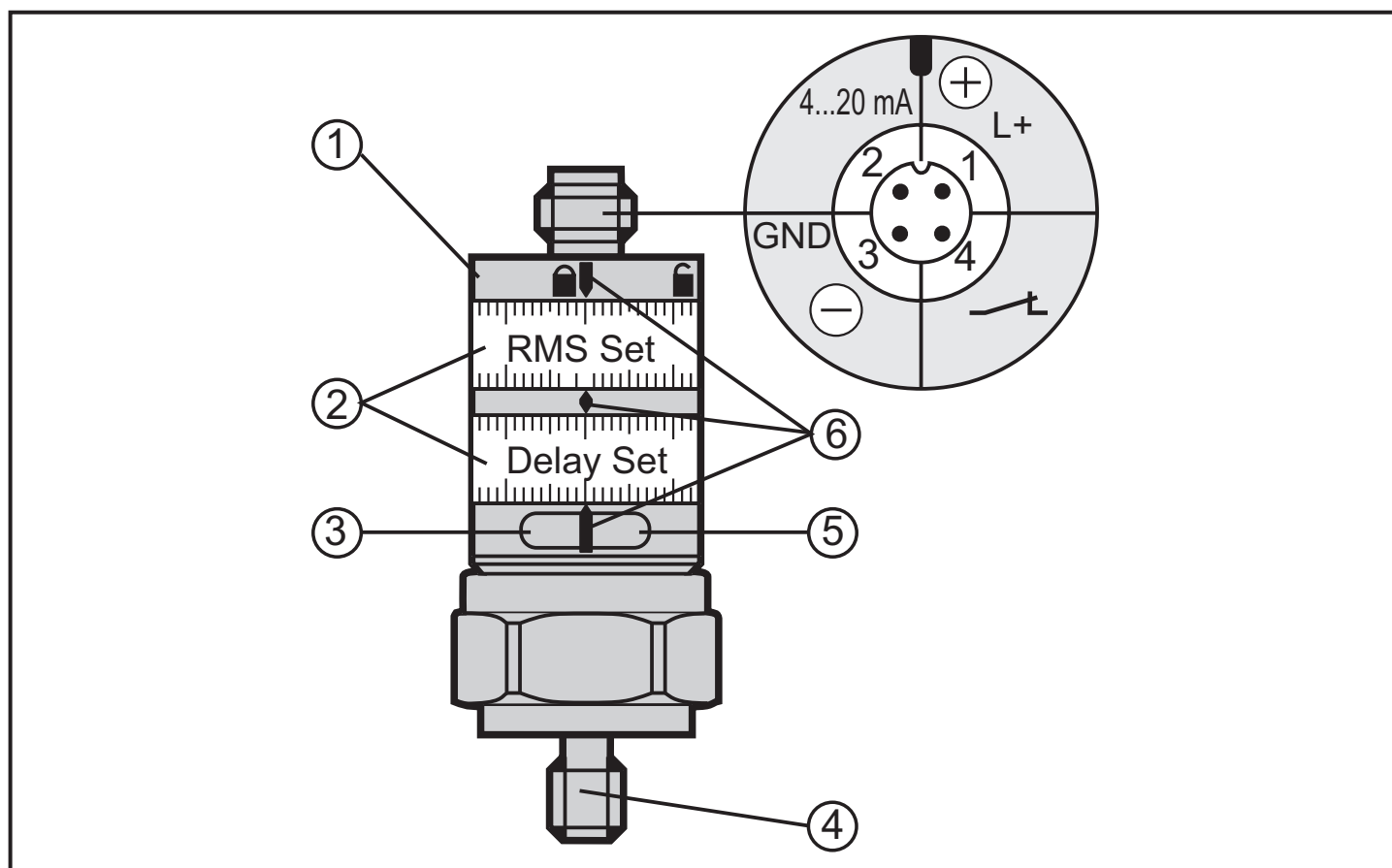

1: locking ring

2: setting rings (manually adjustable after unlocking)

3: LED green: voltage supply

4: M8 process connection

5: LED yellow: lights when switching threshold and time delay are exceeded

6: setting marks



To achieve the setting accuracy: first position the rings to the lower end stop value, then set the requested value.

7 Scale drawing

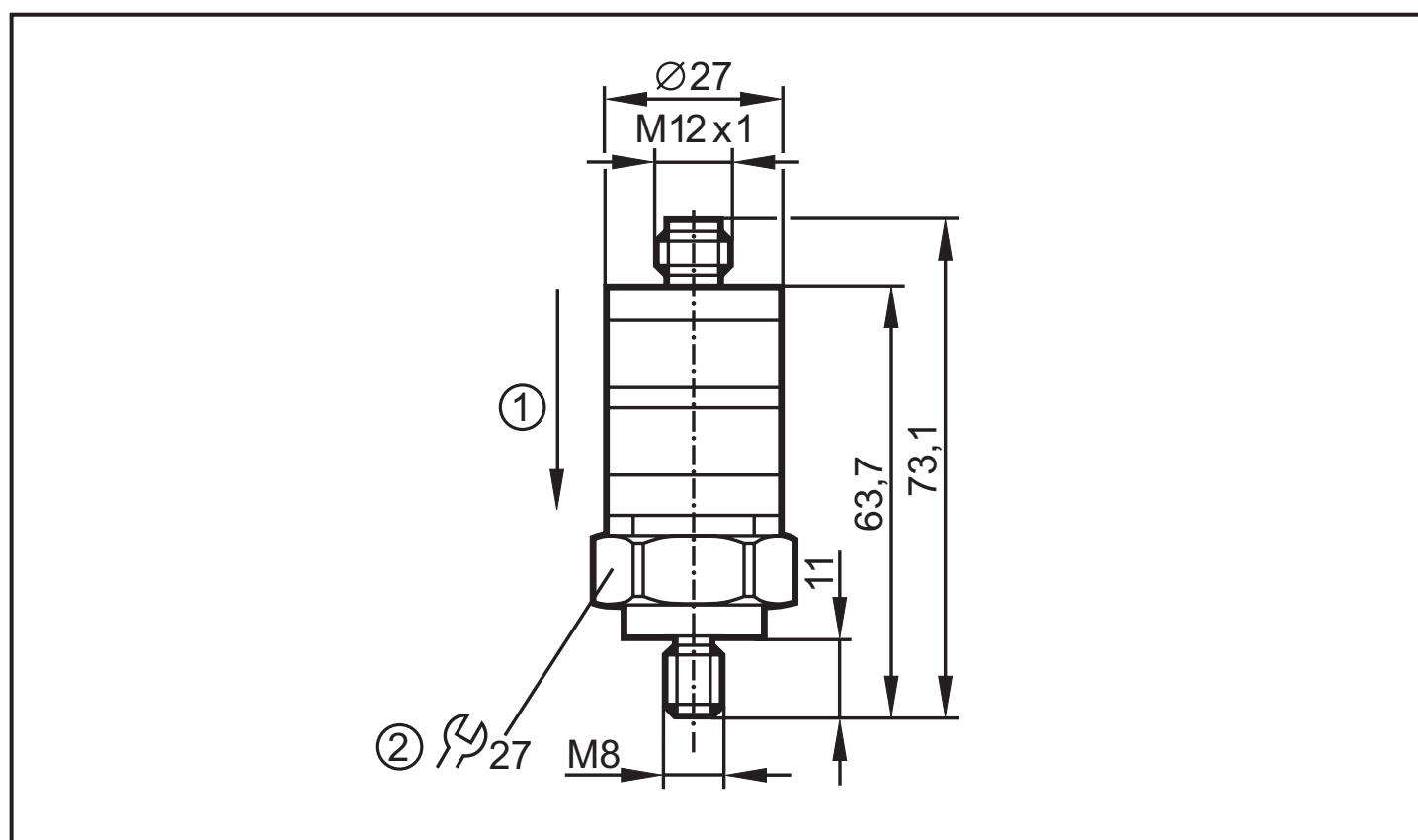

1: measurement axis

2: tightening torque 15 Nm

8 Maintenance, repair, disposal

The operation of the unit is maintenance-free. It is not possible to repair the unit. After use dispose of the unit in an environmentally friendly way in accordance with the applicable national regulations.

9 Technical data

Technical data and further information at
www.ifm.com --> Select your country --> Data sheet direct: