

TUBA 1"

FLOAT LEVEL DETECTOR

For detection with one or several devices according to the use

It is always recommended placing a switch as an ALARM



USE

VR – Emptying / Filling

SIZE

Height: 180 mm – Diameter: 29 mm

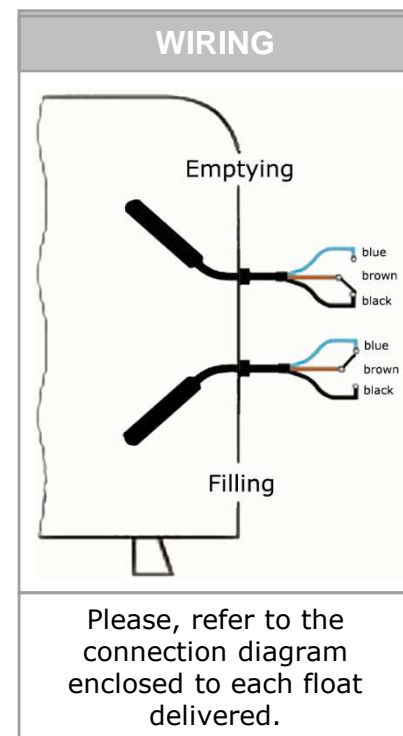
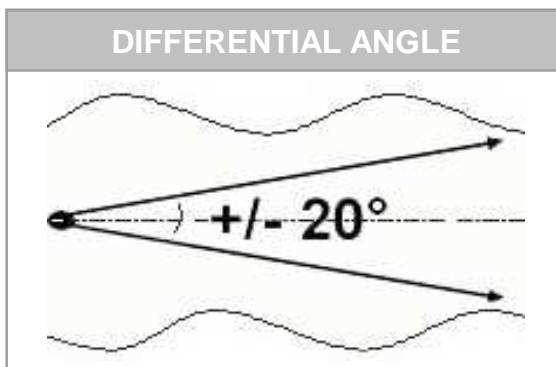

APPLIANCES

Suitable for level detection of liquids in tanks, cisterns, reservoirs and others, such as pump automatic regulation and «ALARM» level detection. Highly recommended for industrial uses. Its small diameter enables the passing through the tank intake holes, with watertightness security thanks to the gland fixed on the electric cable.

TECHNICAL CHARACTERISTICS

Operation mode	Omnidirectional
Allowed fluid density	0,75 to 1,50
Maximum pressure	5,5 bars
Maximum temperature	85°C
Protection index	IP 68 
Electric characteristics	250 VAC- 50/60 Hz
Cut-out power	12 (6) A (12 A resistive - 6 A inductive)
Microswitch	Silver / nickel reverser contacts
Cylindrical shape	Copolymer polypropylene
Cable	Neoprene - A05RN8-F
Cable type	3 conductors 0,75 mm ²
Float weight without cable	60 g
Cable weight	Neoprene 55 g/m
Adjustable ballast on cable (option)	Loaded resin 175 g
Standard cable length (series)	2, 3, 5, 10 and 20m (other lengths on request)