

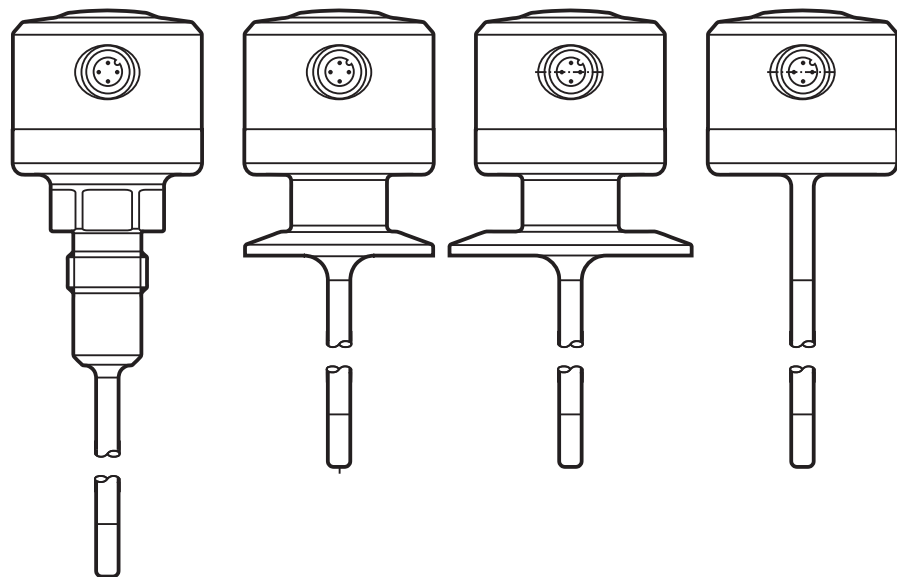

Operating instructions  
Temperature transmitter  
**TCCxxx**

**UK**

80285272 / 00 09 / 2019



# Contents

1 Preliminary note.....	3
1.1 Key to the symbols .....	3
2 Safety instructions .....	3
3 Getting started .....	4
4 Functions and features .....	4
5 Function.....	5
5.1 IO-Link.....	5
5.2 Diagnostic signal .....	6
5.3 Analogue signal .....	6
5.4 Diagnostic function .....	8
5.4.1 Calibration check function .....	8
5.4.2 Diagnostic messages .....	9
5.5 Simulation mode.....	10
5.6 Binary data transmission (BLOB) .....	11
6 Installation.....	11
6.1 Use in hygienic areas to 3-A.....	11
6.2 Use in hygienic areas to EHEDG .....	12
6.3 Units with clamp process connection .....	13
6.4 Units with process connection G ½ sealing cone .....	14
6.4.1 Flush mount hygienic zero-leak using PEEK gasket.....	14
6.4.2 Flush mount zero-leak using metal-to-metal seal.....	14
6.5 Units for process adaptation via clamping ring.....	15
7 Electrical connection.....	16
8 Operating and display elements .....	17
9 Parameter setting .....	17
9.1 Parameters .....	18
9.2 Analysis functions .....	18
10 Operation.....	19
11 Technical data .....	19
12 Troubleshooting .....	19
13 Maintenance, repair and disposal.....	21

# 1 Preliminary note

Technical data, approvals, accessories and further information at [www.ifm.com](http://www.ifm.com).

## 1.1 Key to the symbols

▶ Instruction

> Reaction, result

[...] Designation of keys, buttons or indications

→ Cross-reference



Important note

Non-compliance may result in malfunction or interference.



Information

Supplementary note.

UK

## 2 Safety instructions

- The device described is a subcomponent for integration into a system.
  - The manufacturer is responsible for the safety of the system.
  - The system manufacturer undertakes to perform a risk assessment and to create a documentation in accordance with legal and normative requirements to be provided to the operator and user of the system. This documentation must contain all necessary information and safety instructions for the operator, the user and, if applicable, for any service personnel authorised by the manufacturer of the system.
- Read this document before setting up the product and keep it during the entire service life.
- The product must be suitable for the corresponding applications and environmental conditions without any restrictions.
- Only use the product for its intended purpose (→ Functions and features).
- Only use the product for permissible media (→ Technical data).
- If the operating instructions or the technical data are not adhered to, personal injury and/or damage to property may occur.

- The manufacturer assumes no liability or warranty for any consequences caused by tampering with the product or incorrect use by the operator.
- Installation, electrical connection, set-up, operation and maintenance of the product must be carried out by qualified personnel authorised by the machine operator.
- Protect units and cables against damage.

### 3 Getting started

The unit can be used without any further parameter setting with the settings described under → 14 Factory setting.

If necessary, the factory setting can be changed via the IO-Link interface:

- ▶ Connect unit to PC to set the parameters via the IO-Link interface.
- ▶ Set the standard unit of measurement.
  - [Uni]: °C or °F
- ▶ Set the analogue signal.
  - [OU2]: I = 4...20 mA or Ineg = 20...4 mA or OFF = output off
  - [ASP] and [AEP]: Scaling of the measuring range.
- ▶ Configure the analogue signal for the alarm.
  - [FOU2]: On = 21.5 mA or OFF = 3.5 mA
- ▶ Set the calibration check limit.
  - [ccL]: Temperature deviation from which the unit provides a warning.
- ▶ Configure the switching logic for the alarm and the warning of the diagnostic output.
  - [P-n]: PnP or nPn
- ▶ Activate / deactivate the LED at the head of the unit.
  - [LED]: ON = LED is on (green, blue, red) or OFF = LED off or Notification = LED on for warnings and alarms only
- ▶ Finish parameter setting, install (→ 6), connect (→ 8) and set up the unit.

### 4 Functions and features

The unit detects the medium temperature and provides the measured value via an analogue and/or a digital signal.

The unit features an integrated diagnostic function and a calibration check function (→ 5.4.1). The diagnostic messages are provided via an analogue signal or a switching signal or as a digital communication signal via the IO-Link interface.

The unit has an LED that indicates deviations from normal operation via a colour change (→ 5.4.2).

## 5 Function

- The unit has an IO-Link interface.
- The unit is designed for three-wire operation. The following output signals are available:

OUT1 (2 options):

- diagnostic signal
- IO-Link signal for temperature measurement and diagnostics

OUT2:

- analogue signal for temperature measurement and diagnostics

### 5.1 IO-Link

This unit has an IO-Link communication interface which enables direct access to process and diagnostic data. In addition it is possible to set the parameters of the unit while it is in operation. Operation of the unit via the IO-Link interface requires an IO-Link master.

With a PC, suitable IO-Link software and an IO-Link adapter cable communication is possible while the system is not in operation.

The IO-DDs necessary for the configuration of the unit, detailed information about process data structure, diagnostic information, parameter addresses and the necessary information about the required IO-Link hardware and software can be found at [www.ifm.com](http://www.ifm.com).

The IO-Link interface provides the following functions:

- Remote parameter setting of the unit.
- Noise immune process value transmission without measured value losses.
- Transmission of the parameter settings to other units of the same type or when the unit is replaced.
- Simultaneous reading of the two temperature values (measuring element and reference element), the diagnostic output (calibration check function) and the device status.
- Paperless logging of parameter sets, process values and diagnostic information.

## 5.2 Diagnostic signal

The diagnostic output is only used to provide warnings and alarms (→ data sheet for the maximum nominal current of the switching output).

The switching output is closed in normal operation (normally closed). If the unit detects a diagnostic case, the output opens.

The switching logic (PnP/nPn) and the calibration check limit (ccL) from which the output switches can be set.

The diagnostic messages are defined and cannot be changed (→ 12).

## 5.3 Analogue signal

The unit converts the measured temperature value into a temperature-proportional analogue signal.

In addition the analogue output is used for diagnostics (→ 5.4 Diagnostic function).

The transmission of the measured temperature value is interrupted for alarms and an analogue signal according to NE43 of 3.5 mA (FOU2 = OFF) or 21.5 mA (FOU2 = On) is provided. In case of warnings, the analogue signal continues to be provided.

Depending on the parameter setting (→ 9) the analogue signal for values within the measuring range is:

4...20 mA with setting [OU2] = I or

20...4 mA with setting [OU2] = Ineg.

The measuring range is scalable:

- [ASP] defines at which measured temperature value the analogue signal is 4 mA (OU2 = I) or 20 mA (OU2 = Ineg).
- [AEP] defines at which measured temperature value the analogue signal is 20 mA (OU2 = I) or 4 mA (OU2 = Ineg).



Minimum distance between [ASP] and [AEP] = 5 K.

If the measured temperature value is outside the scaled measuring range, the analogue signal is 20...20.5 mA or 3.8...4 mA (→ Fig.1). When the measured temperature value continues to increase or decrease, the analogue signal goes to the value 3.5 mA or 21.5 mA.

UK

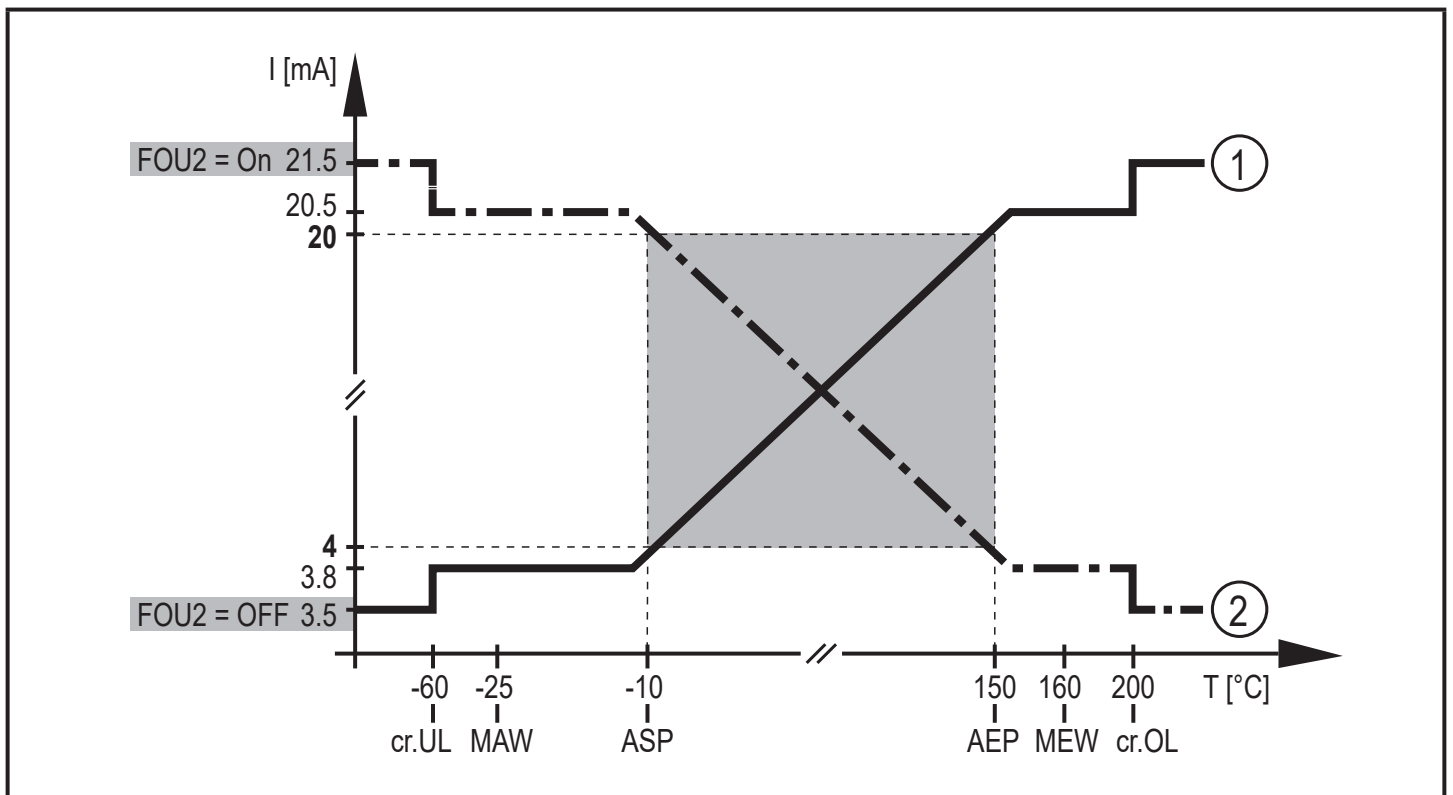

Figure 1: output characteristics analogue output with factory setting

- ① Setting [OU2] = I
- ② Setting [OU2] = Ineg

MAW = initial value of the measuring range, MEW = final value of the measuring range,  
 ASP = analogue start point, AEP = analogue end point  
 cr.UL = below the measuring range, cr.OL = above the measuring range

## 5.4 Diagnostic function

The unit continuously checks the temperature measurement (→ 5.4.1 Calibration check function) and detects further events. In case of deviations from normal operation, a diagnostic message is provided (→ 5.4.2).

### 5.4.1 Calibration check function

By measuring with two different, thermally coupled sensor elements (measuring element and reference element) the unit automatically detects temperature differences during temperature measurement.

The process value is measured by the measuring element and provided via the analogue output. The reference value is used for comparison purposes and to verify the process value. If the temperature difference between the process value and the reference value exceeds the value set as calibration check limit [ccL], a warning is triggered: The LED changes to blue and the diagnostic output opens.

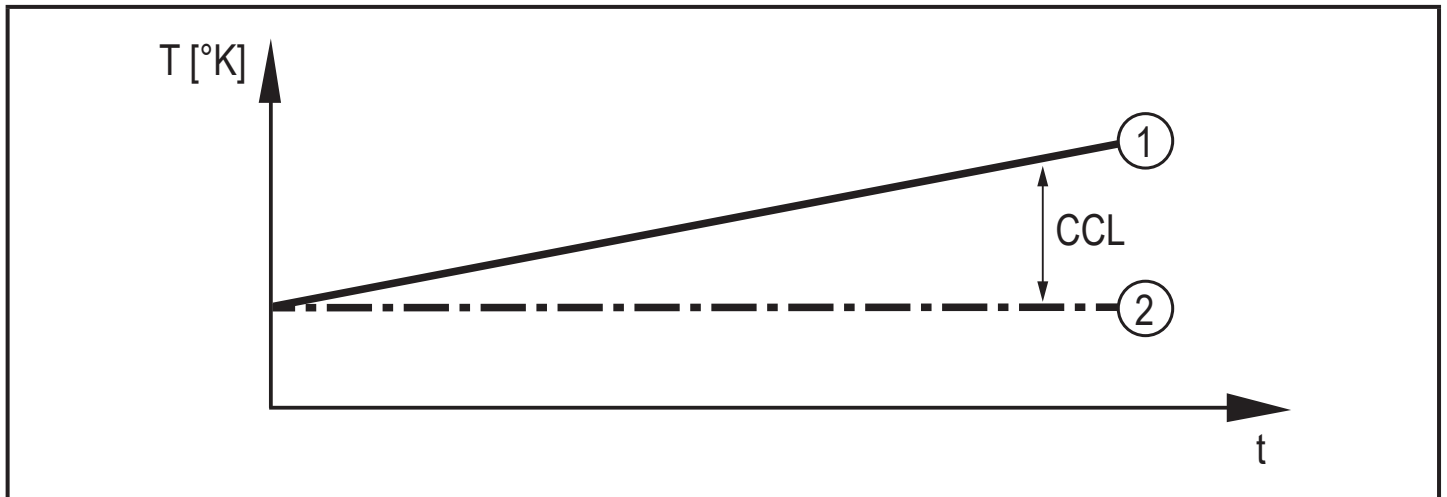

Figure 2: Calibration check function

Example: Measuring element (1) measures 61.05 °C, reference element (2) measures 60 °C. Setting ccL = 1 K results in a warning.



If a warning is triggered, the LED remains blue, even if the temperature difference drops below the ccL value again. Corrective measures:

Check whether the sensor is to remain in use in the process or to be replaced or do as follows:

- ▶ Increase the ccL value so that the LED goes back to green.
- > The diagnostic output closes.
- > The ccL modification is written to the logbook (→ 5.6).



If the reference element fails, the calibration check function fails as well and the LED changes to blue.





Setting range cCL → Technical data.



Due to the usual manufacturing tolerances a temperature difference of max. 0.1 K can also occur with new sensor elements. This does not affect the calibration check function.



To ensure that the calibration check function detects no other influences except the temperature difference between the sensor elements, an internal delay time of 10 minutes has been set.

## 5.4.2 Diagnostic messages

UK

Diagnostic messages are output as follows:

- LED signal:  
The LED shows all warnings and alarms by means of a colour change (blue = warning; red = alarm).
- Diagnostic signal: The diagnostic output provides all warnings and alarms via a switching signal.
- Analogue signal: The analogue output only provides alarms. In case of an alarm the analogue signal goes to 3.5 mA or 21.5 mA.
- IO-Link: If the IO-Link interface is used, all diagnostic messages are displayed via the connected software or provided to the higher-level controller. In addition, a diagnostic bit is provided that corresponds to the behaviour of the physical switching output.



List of all diagnostic messages readable via IO-Link → IO Device Description (IODD) at [www.ifm.com](http://www.ifm.com).



Diagnostics		LED	Diagnostic output	Analogue output
normal operation	<ul style="list-style-type: none"> <li>temperature deviation between measuring element and reference element <math>\leq</math> calibration check limit (ccL)</li> <li>no error</li> </ul>	green		4...20 mA <sup>1)</sup>
warning	<ul style="list-style-type: none"> <li>temperature deviation between measuring element and reference element <math>&gt;</math> calibration check limit (ccL)</li> <li>failure reference element</li> </ul>	blue		4...20 mA <sup>1)</sup>
alarm	<ul style="list-style-type: none"> <li>failure measuring element or failure of both sensor elements</li> <li>other errors <math>\rightarrow</math> 12</li> </ul>	red		21.5 mA <sup>2)</sup>

Table 1: diagnostic function

<sup>1)</sup> For [OU2] = Ineg: 20...4 mA

<sup>2)</sup> For [FOU2] = OFF: 3.5 mA



Warnings are provided with a delay time of 10 minutes. Alarms are provided immediately.

## 5.5 Simulation mode

Normal operation and diagnostic function (warnings and alarms) can be simulated based on freely selected parameters using this function.

- ▶ Set the requested duration of the simulation with [S.Tim].
- ▶ Set a simulation value for the measuring element or select the simulation of a fault of the measuring element with [TEMP].
- ▶ Set a simulation value for the reference element or select the simulation of a fault of the reference element with [REF\_TEMP].
- ▶ Write values to the unit.
- ▶ Click on [Start simulation].
- > The simulation runs for the duration set under [S.Tim].
- ▶ Click on [Stop simulation] to abort the simulation.



- A simulated calibration check warning (LED = blue) is provided with a delay of 30 seconds.
- A simulated alarm (LED = red) is provided without delay.
- During the simulation, [S.On] = On is displayed in the parameter setting software.

## 5.6 Binary data transmission (BLOB)

The unit stores the last 20 events and the last 20 calibration check warnings in an internal ring memory.

- In the [Event log], all events are stored including the operating hours and the event number (Events → 12; table).
- In the [Calibration check alarm log], all calibration check warnings are stored including the operating hours, the measured value, the temperature difference value, the set cCL value and the event status.

UK

## 6 Installation



- ▶ Before installing and removing the unit make sure that no pressure is applied to the system and there is no medium in the pipe.
- ▶ Note dangers related to extreme machine / medium temperatures.

### 6.1 Use in hygienic areas to 3-A

- ▶ Make sure that the sensor is integrated into the system according to 3-A.
- ▶ Use only adapters with 3-A certification and marked with the 3-A symbol (→ accessories at [www.ifm.com](http://www.ifm.com)).

The process connection must be provided with a leakage port. This is ensured when installed using adapters with 3-A approval.



- ▶ For use according to 3-A, take note of the corresponding regulations for cleaning and maintenance.



Not suitable for use where the criteria for paragraph E1.2/63-03 of the 3-A standard 63-03 have to be met.

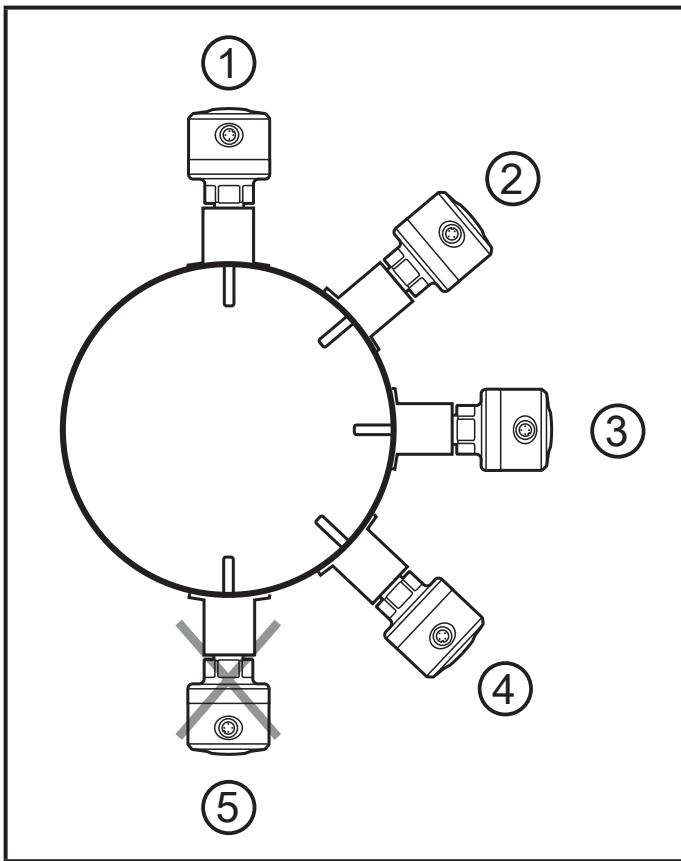

The following applies to units with 3-A certification:

- ▶ Only use adapters with 3-A certification for the process connection.
- ▶ Do not install the unit at the lowest point of the pipe or tank (→ position 5) in order that the medium can run off the area of the sensor elements.

## 6.2 Use in hygienic areas to EHEDG



The sensor is suited for CIP (cleaning in process) when installed correctly.

- ▶ Observe the application limits (temperature and material resistance) according to the data sheet.
- ▶ Make sure that the sensor is integrated into the system according to EHEDG.
- ▶ Use self-draining installation.
- ▶ Only use process adapters permitted according to EHEDG with special seals required by the EHEDG position paper.



The gasket of the system interface must not be in contact with the sealing point of the sensor.

- ▶ In case of structures in a tank, the installation must be flush mount. If not possible then direct water jet cleaning and cleaning of dead spaces must be possible.
- ▶ Leakage ports must be clearly visible and must be installed facing downwards for vertical pipes.
- ▶ Adhere to the dimensions shown in Fig. 1 to avoid dead space:  $L < (D - d)$ .

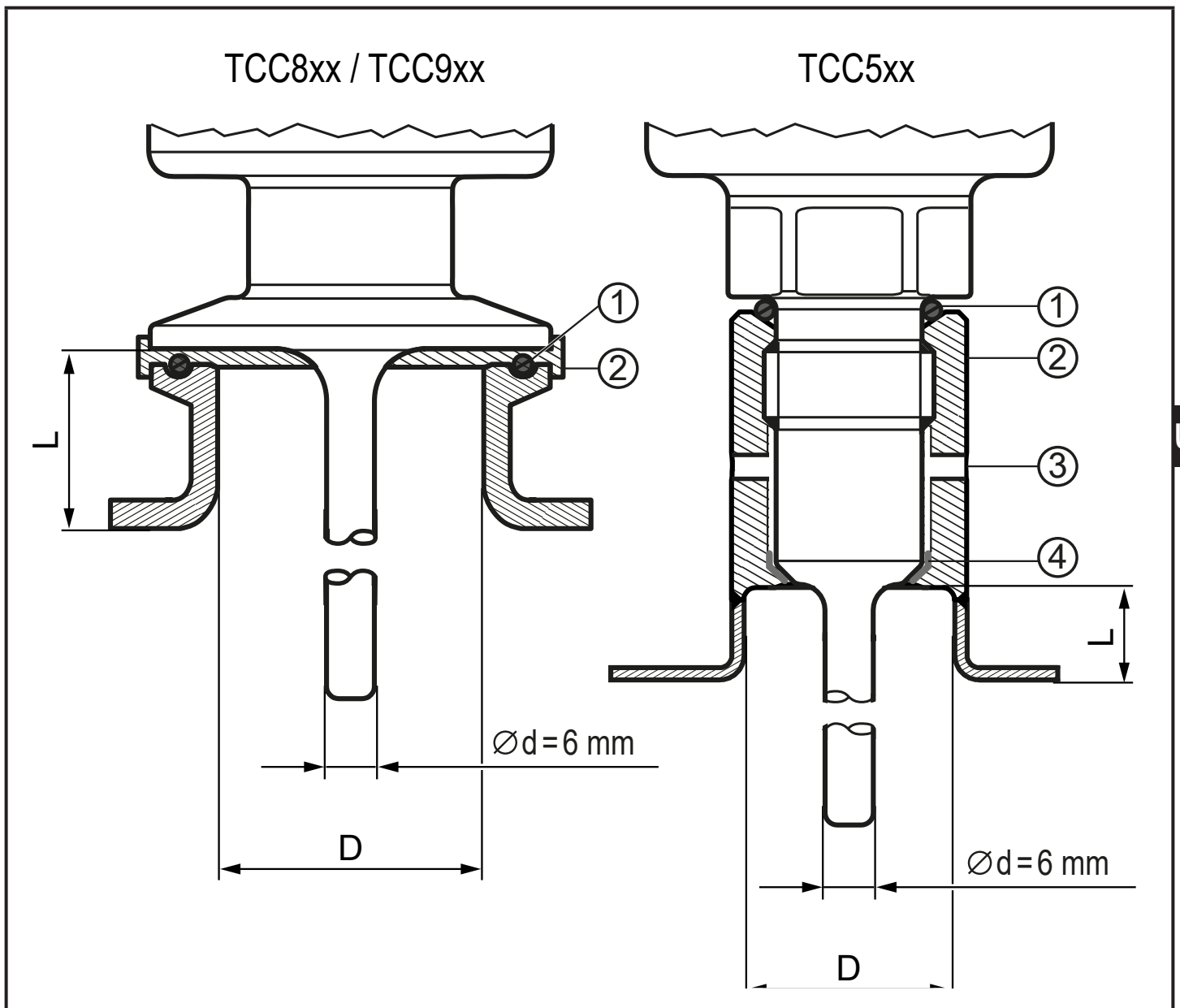

Fig. 1: mounting dimensions for use according to EHEDG

- 1: sealing ring between the housing and the process connection
- 2: adapter
- 3: leakage port
- 4: PEEK gasket

### 6.3 Units with clamp process connection

The one-piece units of design TCC8xx with clamp 1.5" and of design TCC9xx with clamp 2" are best suited for a hygienic installation.

► Observe the notes on installation:

- 6.1 Use in hygienic areas to 3-A
- 6.2 Use in hygienic areas to EHEDG

## 6.4 Units with process connection G ½ sealing cone

The units of design TCC5xx can be adapted to standard process connections using two sealing versions: The following applies to both sealing versions:



- ▶ Only use accessories from ifm electronic. The optimum function is not ensured when using components from other manufacturers.



- ▶ Observe the instructions of the adapter.

The sealing ring between the housing and the process connection (Fig. 1 → 6.2) can compensate for variable insertion depths and tolerances and provides protection against the ingress of media in the thread area.



- ▶ The sealing ring between the housing and the process connection cannot compensate for the system pressure.

### 6.4.1 Flush mount hygienic zero-leak using PEEK gasket

- ▶ Use the supplied PEEK gasket.
  - The PEEK gasket is suited for use in hygienic installations to EHEDG and 3-A.
  - The PEEK gasket is long-term stable and maintenance-free.
  - When the PEEK gasket is mounted several times, check and replace it if necessary.
  - The PEEK gasket has been rated for ifm adapters with end stop towards the medium.
- ▶ Use adapters with leakage ports.
- ▶ Screw the sensor into the adapter. Recommended tightening torque 20 Nm.
- ▶ Observe the notes on installation:
  - 6.1 Use in hygienic areas to 3-A
  - 6.2 Use in hygienic areas to EHEDG

### 6.4.2 Flush mount zero-leak using metal-to-metal seal



- ▶ A long-term stable, maintenance-free and gap-free fitting in the metal-to-metal seal is only valid for once-only mounting.

- ▶ Do not use the supplied PEEK gasket.
- ▶ Screw the sensor into the adapter. Recommended tightening torque 20 Nm.

## 6.5 Units for process adaptation via clamping ring

The units of design TCC2xx can be mounted in the pipe or in the tank directly in contact with the medium via a clamping ring adapter. Mounting examples:

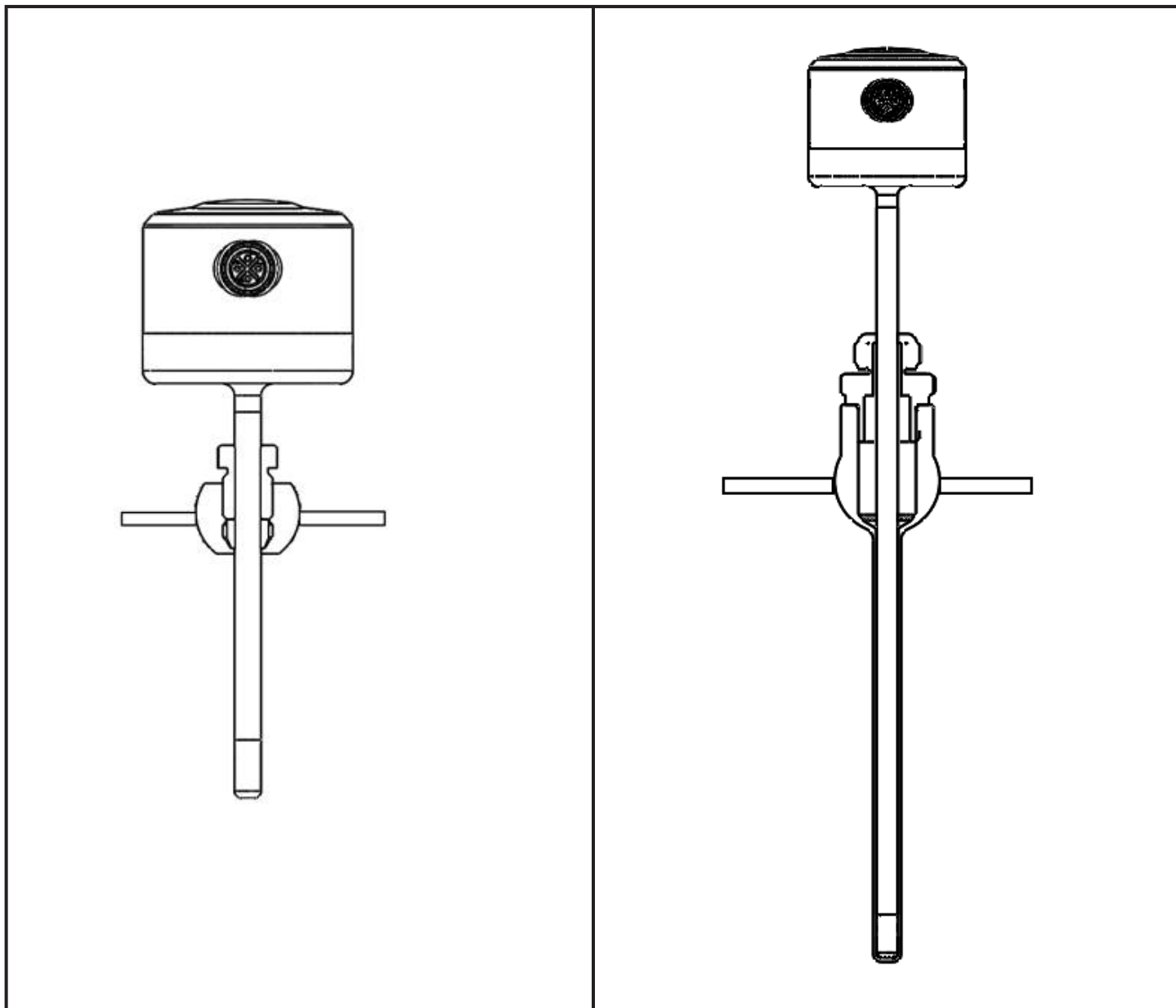

Fig. 2: direct installation  
(e.g. with adapter E30407)

Fig. 3: installation with protective tube  
(e.g. with adapter E37421)

# 7 Electrical connection



The unit must be connected by a qualified electrician. Voltage supply according to EN 50178, SELV, PELV.



The unit is designed exclusively for 3-wire operation.

- ▶ Disconnect power.
- ▶ Connect the unit as follows:

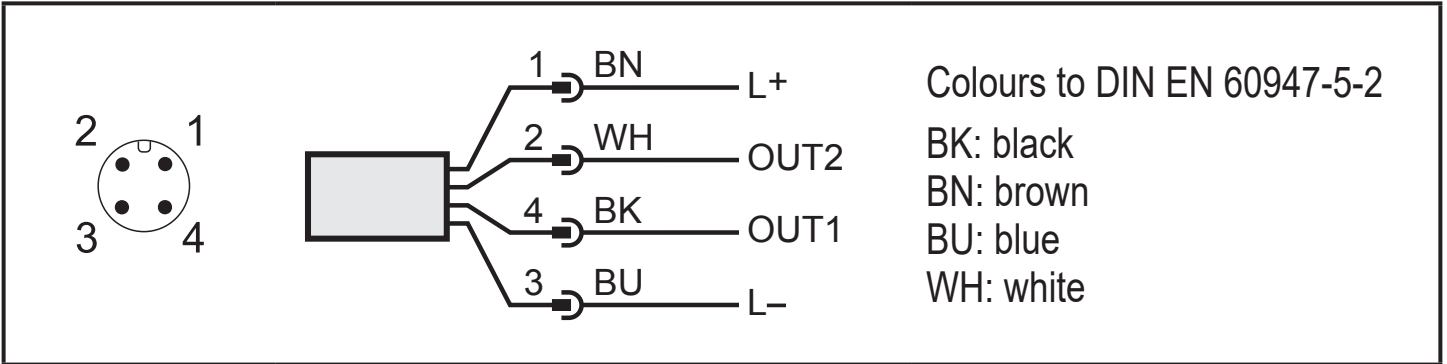

Pin	Assignment
4 (OUT1)	<ul style="list-style-type: none"> <li>• diagnostic signal</li> <li>• IO-Link signal for temperature measurement and diagnostics</li> </ul>
2 (OUT2)	<ul style="list-style-type: none"> <li>• analogue signal for temperature measurement and diagnostics</li> </ul>

## Circuit examples:

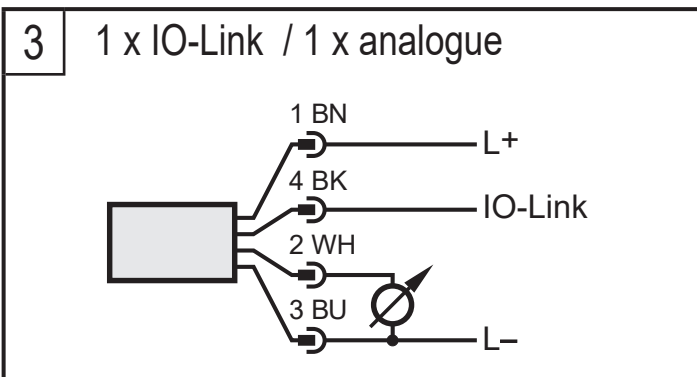
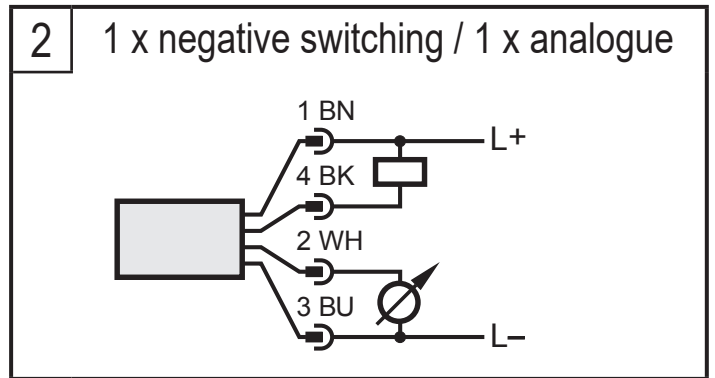
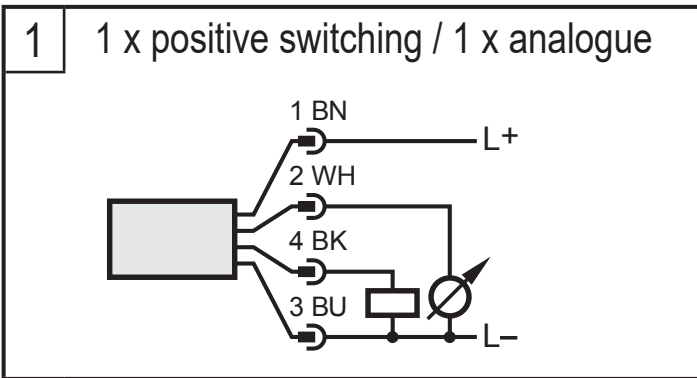



## 8 Operating and display elements

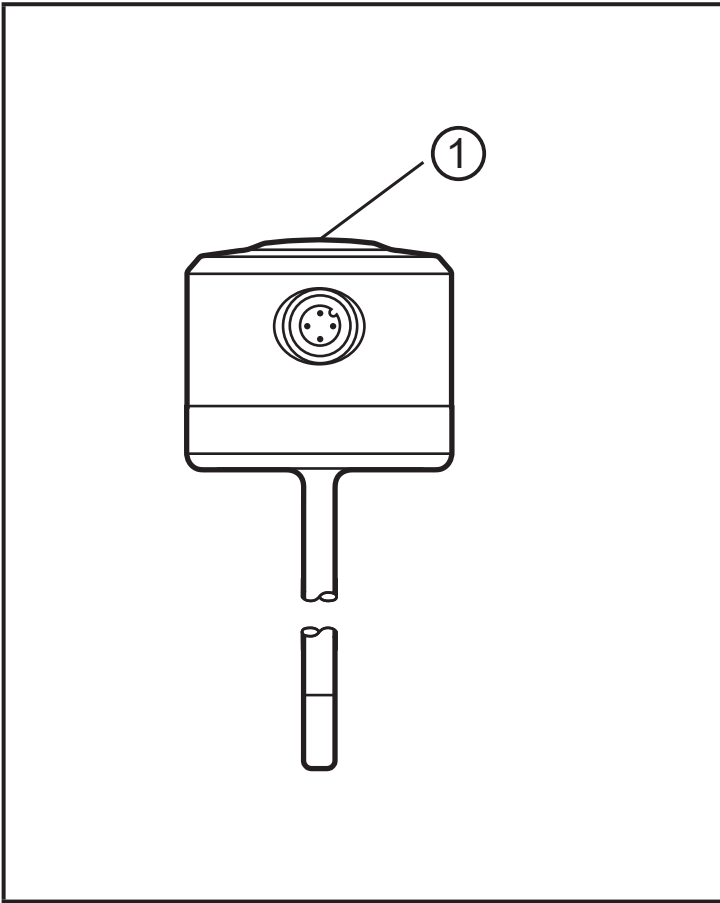

- At the head of the unit is an LED that is green during normal operation.
- If the deviation between the sensor elements is too high, the LED changes to blue (→ 5.4.1 Calibration check function).
- In case of an alarm, the LED changes to red.
- In case of a shorted circuit, the LED flashes red.
- When the command for identifying a sensor in the plant is used, the LED flashes green.

1: LED (green, blue, red)

UK

## 9 Parameter setting

Parameters can be set via the IO-Link interface before installation and set-up of the unit or during operation.



If you change parameters during operation, this will influence the function of the plant.

- ▶ Ensure that there will be no malfunctions in your plant.

During parameter setting the unit remains in the operating mode. It continues to monitor with the existing parameter until the parameter setting has been completed.

- ▶ Connect the unit to a parameter setting software via suitable hardware.
- ▶ Set parameters or use the analysis function.

## 9.1 Parameters

Parameter	Explanation
ou2	Configuration of the analogue signal: I = 4...20 mA or Ineg = 20...4 mA or OFF = output off
P-n	Switching logic for the diagnostic output: PnP or nPn.
ASP2	Analogue start point for measured temperature value.
AEP2	Analogue end point for measured temperature value.
FOU2	Analogue signal in case of an alarm: On = 21.5 mA; OFF = 3.5 mA.
ccL	Calibration check limit = temperature deviation between the process value and the reference value from which the unit provides a warning.
uni	Setting of the standard unit of measurement: °C or °F.
LED mode	The LED on the unit can be switched on and off: On = LED always on Off = LED always off Notification = LED only on in case of a warning or an alarm.
Restore Factory Settings	Restore the factory settings.  We recommend recording your own settings before carrying out a reset (→ 14 Factory setting).

## 9.2 Analysis functions

Displays / commands	Explanation
Free-text fields for device information	<ul style="list-style-type: none"> <li>- Application Specific Tag</li> <li>- Function Tag</li> <li>- Location Tag</li> <li>- Installation date</li> </ul>
Diagnostics display	<ul style="list-style-type: none"> <li>- Hi = highest temperature value measured</li> <li>- Lo = lowest temperature value measured</li> </ul>
Flash On / Flash Off	The LED starts flashing, allowing easy identification of the unit in the field.
Reset <ul style="list-style-type: none"> <li>- [Hi] and [Lo] memory</li> <li>- [Hi] memory</li> <li>- [Lo] memory</li> </ul>	Reset the maximum and/or minimum value memories

Displays / commands	Explanation
Simulation	Simulation of temperature measurement (measuring element and reference element) and diagnostic cases without operation → 5.5 Simulation mode.
Protocols (log entries)	<ul style="list-style-type: none"> <li>- Device status</li> <li>- Detailed device status</li> <li>- Event history</li> <li>- Operating hours since first set-up</li> <li>- Operating hours history memory (sampling rate 1 s)</li> <li>- Internal temperature</li> <li>- Parameter configuration faults</li> </ul>
Binary file transfer (BLOB)	Command for storing a log file on all calibration check warnings or events → 5.6.

## 10 Operation

When the supply voltage is applied, the unit is in the RUN mode after a power-on delay time of 6 s (= normal operating mode). It carries out its measurement and evaluation functions and provides output signals according to the set parameters.

## 11 Technical data

→ Technical data at [www.ifm.co](http://www.ifm.co).

## 12 Troubleshooting

The unit has many self-diagnostic options. It monitors itself automatically during operation (→ 5.4 Diagnostic function).

Diagnostic messages are indicated via the LED (LED blue = warning; LED red = alarm).

These messages are also available via IO-Link.

- ▶ Connect the unit to a PC and read it via the IO-Link interface.
- ▶ Carry out corrective measures to restore normal operation.

<b>Diagnostics</b>	<b>Event</b>	<b>LED</b>	<b>Corrective measures</b>
calibration check warning (temperature deviation between the two sensor elements exceeds cCL)	0x8CAE (36014)	blue	<ul style="list-style-type: none"> <li>▶ check the unit and adapt cCL, if necessary</li> <li>▶ replace unit</li> </ul>
failure reference element	0x5010 (20496)	blue	▶ prepare replacement of the unit
failure measuring element	0x5010 (20496)	red	▶ replace unit
hardware failure of the unit	0x5000 (20480)	red	▶ replace unit
parameter error	0x6320 (25376)	red	▶ check the validity of the set parameter values (→ data sheet)
short circuit	0x7710 (30480)	flashes red	▶ check the installation
measuring range significantly exceeded (process value exceeds cr.OL or does not reach cr.UL → 5.3, Fig. 1)	0x8C20 (35872)	red	▶ check the temperature range
PV Overrun (process value exceeds MEW → 5.3, Fig.1)	0x8C10 (34576)	no effect*	▶ check the temperature range
PV Underrun (process value does not reach MAW → 5.3, Fig. 1)	0x8C30 (34608)	no effect*	▶ check the temperature range
internal unit temperature too high (> 125°C / 257°F)	0x4210 (16912)	no effect*	▶ remove the heat source
simulation active	0x8C01 (35841)	no effect**	▶ terminate the simulation mode
flashing function for sensor localisation active	0x8CDB (36059)	flashes green	▶ terminate the flashing function with the "Flash Off" command

\* LED colour depends on the current operating status.

\*\* LED colour depends on the simulated operating status.

MAW = initial value of the measuring range

MEW = final value of the measuring range

## 13 Maintenance, repair and disposal

If used correctly, no maintenance and repair measures are necessary.

Only the manufacturer is allowed to repair the unit.

- ▶ After use dispose of the unit in an environmentally friendly way in accordance with the applicable national regulations.
- ▶ Define regular calibration intervals according to the process requirements.

## 14 Factory setting

Parameter	Factory setting	User setting
OU2	I	
ASP	-10 °C	
AEP	150 °C	
ccL	1 K	
FOU2	On	
P-n	PnP	
Uni	°C	
LED	On	
Simulation mode	process value: 20 °C reference value: 20 °C S.Tim: 3 min	

UK