

Optical Dissolved Oxygen
Online Analyzer

Preface

Thank you for purchasing the Optical Dissolved Oxygen Online Analyzer. Please read this manual carefully before operating and using it correctly to avoid unnecessary losses caused by false operation.

Note

- Modification of this manual's contents will not be notified as a result of some factors, such as function upgrading.
- We try our best to guarantee that the manual content is accurate, if you find something wrong or incorrect, please contact us.
- This product is forbidden to use in explosion-proof occasions.

Version

U-DO2.2-MYEN1

Safety Precautions

In order to use this product safely, be sure to follow the safety precautions described.

About this manual

- Please submit this manual to the operator for reading.
- Please read the operation manual carefully before applying the instrument. On the precondition of full understanding.
- This manual only describes the functions of the product. The company does not guarantee that the product will be suitable for a particular use by the user.

Precautions for protection, safety and modification of this product

- To ensure safe use of this product and the systems it controls, Please read carefully the operation manual and understand the correct application methods before putting into operation, to avoid unnecessary losses due to operation mistakes. If the instrument is operated in other ways not described in the manual, the protections that the instrument give may be destroyed, and the failures and accidents incurred due to violation of precautions shall not be borne by our company.
- When installing lightning protection devices for this product and its control system, or designing and installing separate safety protection circuits for this product and its control system, it needs to be implemented by other devices.
- If you need to replace parts of the product, please use the model specifications specified by the company.
- This product is not intended for use in systems that are directly related to personal safety. Such as nuclear power equipment, equipment using radioactivity, railway systems, aviation equipment, marine equipment, aviation equipment and medical equipment. If applied, it is the responsibility of the user to use additional equipment or systems to ensure personal safety.

-
- Do not modify this product.
 - The following safety signs are used in this manual:



Hazard, if not taken with appropriate precautions, will result in serious personal injury, product damage or major property damage.



Warning: Pay special attention to the important information linked to product or particular part in the operation manual.



- Confirm if the supply voltage is consistent with the rated voltage before operation.
- Don't use the instrument in a flammable and combustible or steam area.
- To prevent from electric shock, operation mistake, a good grounding protection must be made.
- Thunder prevention engineering facilities must be well managed: the shared grounding network shall be grounded at is-electric level, shielded, wires shall be located rationally, SPD surge protector shall be applied properly.
- Some inner parts may carry high voltage. Do not open the square panel in the front except our company personnel or maintenance personnel acknowledged by our company, to avoid electric shock.
- Cut off electric powers before making any checks, to avoid electric shock.
- Check the condition of the terminal screws regularly. If it is loose, please tighten it before use.
- It is not allowed to disassemble, process, modify or repair the product without authorization, otherwise it may cause abnormal operation, electric shock or fire accident.
- Wipe the product with a dry cotton cloth. Do not use alcohol, benzene or other organic solvents. Prevent all kinds of liquid from splashing on the product. If the product falls into the water, please cut off the power

immediately, otherwise there will be leakage, electric shock or even a fire accident.

- Please check the grounding protection status regularly. Do not operate if you think that the protection measures such as grounding protection and fuses are not perfect.
- Ventilation holes on the product housing must be kept clear to avoid malfunctions due to high temperatures, abnormal operation, shortened life and fire.
- Please strictly follow the instructions in this manual, otherwise the product's protective device may be damaged.



- Don't use the instrument if it is found damaged or deformed at opening of package.
- Prevent dust, wire end, iron fines or other objects from entering the instrument during installation, otherwise, it will cause abnormal movement or failure.
- During operation, to modify configuration, signal output, startup, stop, operation safety shall be fully considered. Operation mistakes may lead to failure and even destruction of the instrument and controlled equipment.
- Each part of the instrument has a certain lifetime, which must be maintained and repaired on a regular basis for long-time use.
- The product shall be scrapped as industrial wastes, to prevent environment pollution.
- When not using this product, be sure to turn off the power switch.
- If you find smoke from the product, smell odor, abnormal noise, etc., please turn off the power switch immediately and contact the company in time.

Disclaimer

- The company does not make any guarantees for the terms outside the scope of this product warranty.
- This company is not responsible for damage to the instrument or loss of parts or unpredictable damage caused directly or indirectly by improper operation of the user.

No.	Name	Quantity	Note
1	Optical dissolved oxygen controller	1	
2	Manual	1	
3	Certificate	1	

After opening the box, please confirm the package contents before starting the operation. If you find that the model and quantity are incorrect or there is physical damage in appearance, please contact us.

Contents

Chapter 1 Production Introduction.....	1
1.1 Characteristics.....	1
1.2 Parameter.....	2
1.3 Application Scope.....	2
Chapter 2 Fixation & Installation.....	3
2.1. Installation of instrument.....	3
2.1.1 Installation precautions.....	3
2.1.2 Installation should be kept away from the following site.....	3
2.1.3 Installation methods.....	3
2.1.4 Sensor dimension/wiring.....	5
Chapter 3 Push-button Operation.....	8
3.1 Button display.....	8
3.2 Definition of buttons.....	8
Chapter 4 HMI and Operation.....	9
4.1 Monitoring page.....	9
4.2 Password verification page.....	9
4.3 Main menu.....	10
Chapter 5 Configuration.....	11
5.1 System configuration.....	11
5.2 Signal configuration.....	11
5.3 Online calibration.....	12
5.4 Remote Transmission Configuration.....	12
5.5 Alarm configuration.....	12
5.6 Version inquiry.....	13
Chapter 6 Communication.....	13
Chapter 7 Failure Analysis & Trouble-shooting.....	15

Chapter 1 Production Introduction

Optical Dissolved Oxygen Online Analyzer, an intelligent online chemical analyzer, is widely applied for continuous monitoring and measurement of dissolved oxygen, saturation, oxygen partial pressure and temperature in the solution in the industry of thermal power, chemical fertilizer, environmental protection, metallurgy, pharmacy, biochemistry, food and water, etc.

Continuous monitoring measurement data is connected with the recorder via transmitting output to realize remote monitoring and recording. It can also be connected with RS485 portal via MODBUS-RTU protocol to access computer for monitoring and recording.

1.1 Characteristics

- 2.8 inches 12864 lattice screen.
- Isolating transmitting output, with little interference.
- Isolating RS485 communication.
- DO/SAT measurement, temperature measurement,
- upper/lower limit control, transmitting output, RS485 communication.
- Configurable upper/lower limit alarm and delay.
- Configurable hummer and LCD backlight switch.
- Optional language, Chinese and English.
- Air calibration.

1.2 Parameter

Measuring range	0 - 20mg/L, 0 - 200%
Accuracy	±0.5%mg/L
Temperature range	0 - 60℃
Correction accuracy	±0.5℃
Signal output	4 - 20mA current transmission output, Max. loop resistance: 500Ω
Communication	RS485 Modbus-RTU
Power supply	AC220V±10%, 5W Max, 50Hz
Relay out	AC250V、3A

1.3 Application Scope

- Sewage treatment
- Waste water treatment
- Water treatment
- Drinking water
- Surface water: river, lake and sea
- Fishery
- Boiler feed water (trace oxygen measurement)

Chapter 2 Fixation & Installation

2.1.Installation of instrument

Please read the instruction of installation location and method of instrument as described during installation.

2.1.1Installation precautions

The instrument serves mainly for detection and transmission, not dedicated for control. It is equipped with a relay switch output, for warning and reminding use generally. If the user involves the function in participating loop control, the failure of the instrument may lead to major accident or destruction of other equipment, emergency stop electric circuit and protection loop should be set up. Otherwise, the company will not be liable for any consequences incurred.

The instrument is panel-mounted and should be installed indoor, sheltered from wind, rain and direct sunlight. To avoid rise of temperature inside the instrument, it should be installed at a well-ventilated place. Do not tilt it during installation and try to locate it horizontally (tilting back<30°).

2.1.2 Installation should be kept away from the following site

- In direct exposure to sunlight and near thermal equipment.
- With ambient temperature over 60 degrees in operation.
- With humidity over 85% in operation.
- Nearby electromagnetic source.
- In strong mechanical vibration.
- With varying temperature and dew condensation.
- With oil smoke, steam, humidity, dust and corrosive gases.

2.1.3 Installation methods

Open a 92.5 * 92.5(mm) installation hole on the instrument cabinet or installation panel (the dimension is 100*100*150mm).

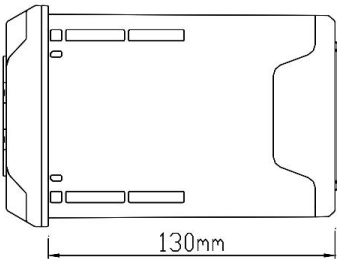
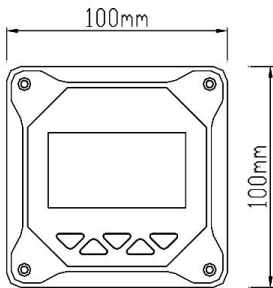
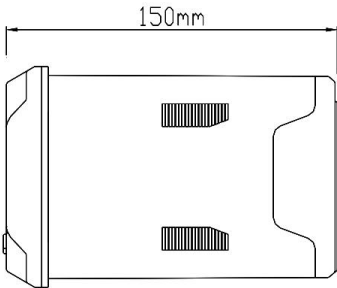
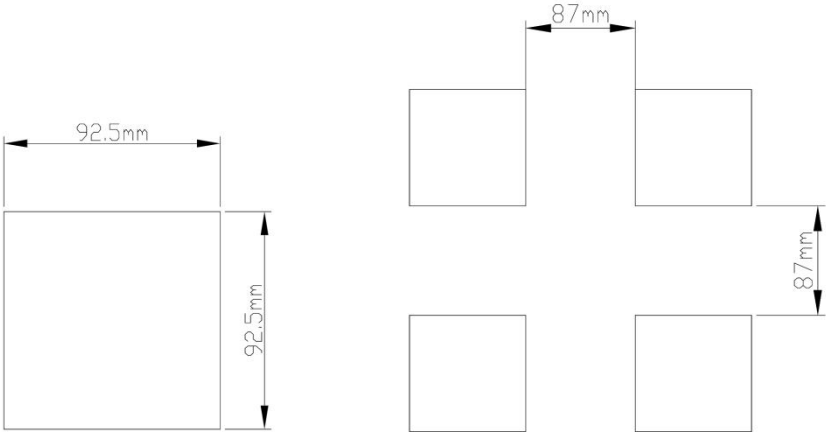

Insert the meter into the mounting hole and fix the butterfly buckle:

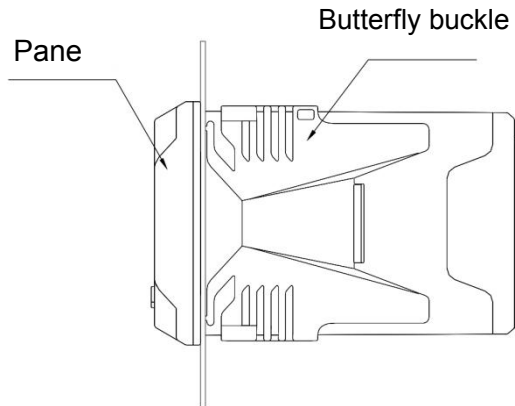

2.1.4 Sensor dimension/wiring

- **Sensor Dimension**

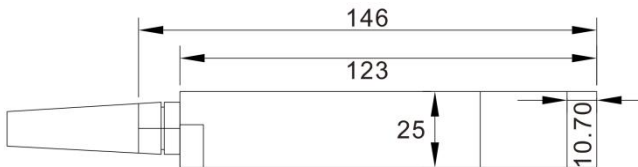

- **Sensor Wiring**

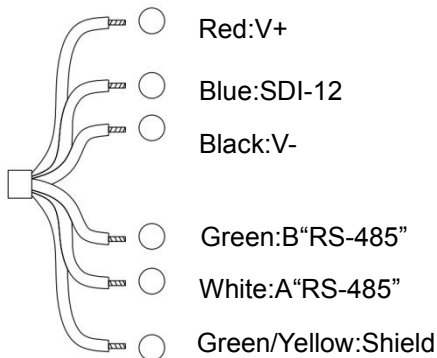

Wiring of instrument

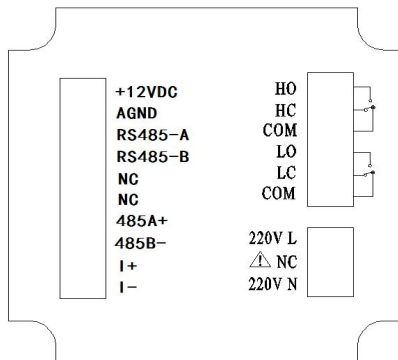

Wiring diagram

Identification of terminal

- +12VDC: Power supply of dissolved oxygen electrode
- AGND: Power negative of dissolved oxygen electrode
- RS485-A: Dissolved oxygen electrode communication-A
- RS485-B: Dissolved oxygen electrode communication-B
- NC: Null
- NC: Null
- RS485(A+): RS485 communication interface A+
- RS485(B-): RS485 communication interface B-
- I(+): 4-20mA output port +
- I(-): 4-20mA output port -
- HO: High alarm of normal open relay
- HC: High alarm of normal close relay
- COM: Common port
- LO: Low alarm of normal open relay
- LC: Low alarm of normal close relay
- COM: Common port
- 220V L: AC220V fire wire
- NC: Null
- 220V N: AC220V zero wire

Attention



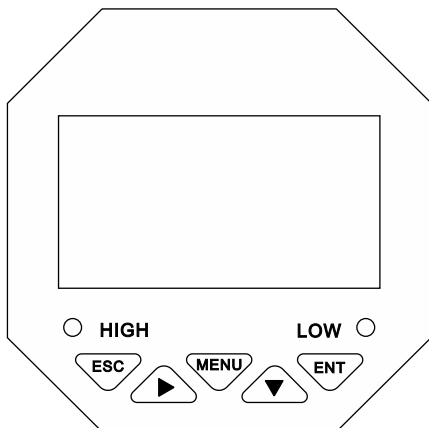

- Confirm that the instrument is not power on before connected with signal wire, to avoid electric shock.
- Use double insulation wire to prevent fire accident.
- Do not put electric product close to signal terminal, which may cause failure.

Chapter 3 Push-button Operation

3.1 Button display



3.2 Definition of buttons

Sign	Button Name	Function description
	EXIT	Check the related alarm status on the “monitoring page” Return to previous level page in the up& down level page linked to “menu page”
	MOVE RIGHT	Make a recurrent selection of digit of parameters Check the display values of other unit on the “monitoring page”
	MENU	Enter the MENU on the “monitoring page” Exit the MENU on the “menu page”
	MOVE DOWN	Select the related menu on the “menu page” Modify the values in the configuration state
	ENTER	Enter the submenu or confirm modification on the “menu page”

Chapter 4 HMI and Operation

4.1 Monitoring page

- The instrument is equipped with monochrome lattice LCD, 128*64 resolution.
- Push [MENU] to enter password verification page; input password to enter the home page.
- Push [EXIT] to enter alarm inquiry page, to inquire the current alarm configuration information.

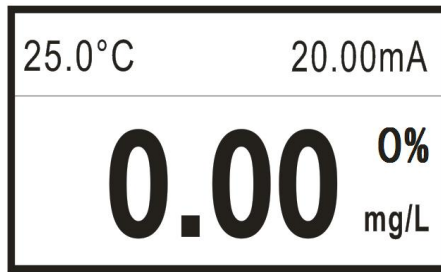

Main monitoring page

4.2 Password verification page

- Input password and push [ENTER] to enter home page.
- Initial password is 0000, which can be modified via password modification function.
- Please contact us if you forget your password

----User Password----

Password: 0000

4.3 Main menu

----- Main Menu -----

- ▶ 1. System Setting
- 2. Signal Setting
- 3. Online Calibration
- 4. Remote Setting
- 5. Alarm Setting
- 6. Version Query

- System Setting: settings of language, buzzer and backlight, modification of password and factory settings
- Signal Setting: settings of signal correction, slope, air pressure offset, salinity and response time.
- Online Calibration: Electric pole's air Calibration
- Remote Setting: settings of RS485 parameters and current transmission output.
- Alarm Setting: settings of parameters of high and low alarm.
- Version Query: current version number

Chapter 5 Configuration

5.1 System configuration

----- System Setting -----

- ▶ 1. Language
- 2. Buzzer
- 3. Backlight Setting
- 4. Change Password
- 5. Factory Setting

- Language: switch of language, Chinese and English.
- Buzzer: setting of switch of buzzer during alarm.
- Backlight Setting: setting of LCD backlight.
- Change Password: password modification and log-in with new password.
- Factory Setting: back to factory settings

5.2 Signal configuration

----- Signal Setting -----

- ▶ 1. Electrode Factory
- 2. Air Pressure Setting
- 3. Salt content setting

- Electrode factory: The electrode restores the factory calibration coefficient, and the air pressure compensation restores to the default value of 1013hPa. The salinity returns to the default value of 0.00ppt.
- Air Pressure Setting: set the air pressure value of the current altitude.

The default value is the standard atmospheric pressure, 1013hPa.

- Salt Content Setting: set the salinity of the current solution. The default is 0.00ppt.

5.3 Online calibration

----- Online Calibration -----
➡ 1.Air Calibration

- Air Correction: In case of air and Saturated oxygen solution to calibrate, push [ENTER] to calibrate.

5.4 Remote Transmission Configuration

----- Remote Setting -----
➡ 1.RS485 Setting
2.Current Transmission

- RS485 Setting: set 485 communication address and baud rate.
- Current Transmission: set 4mA corresponding value and 20mA corresponding value of 4-20mA output.

5.5 Alarm configuration

----- Alarm Setting -----
➡ 1.DO High Alarm
2.DO Low Alarm

- DO High Alarm: when the measured value is higher than high alarm pull-on value, high alarm relay pulls on; when the measured value is lower than high alarm cut-off value, high alarm relay cuts off.
- DO Low Alarm: when the measured value is lower than low alarm pull-on value, low alarm relay pulls on; when the measured value is higher than lower alarm cut-off value, low alarm relay cuts off.

5.6 Version inquiry

-----Version Query-----

- Version Query: inquire the current hard software version, which is high traceable.

Chapter 6 Communication

The instrument is provided with standard RS485 series communication interface, in accordance with international universal standard MODBUS-RTU communication protocol, supporting No.03 register reading and holding command.

MODBUS standard format (read and hold command from Register 03)

Command format:

Definition	Address	Function code	Register address	Data number	CRC check
Data	ADDR	0x03	M	N	CRC 16
Bytes	1	1	2	2	2

Return format:

Definition	Address	Function code	Register address	Data number	CRC check
Data	ADDR	0x03	2*N	Data	CRC 16
Bytes	1	1	1	2*N	2

Descriptions of register address:

Address	Data type	Data size	Function code	Description	Access authority
0x0000	short	2 bytes	0x03	DO value (unit:mg/L, to be divided by 100)	Read only
0x0001	short	2 bytes	0x03	Temperature value (unit: °C, to be divided by 10)	Read only
0x0002	short	2 bytes	0x03	Saturation value (unit: %, to be divided by 10)	Read only

Example of DO reading:

Computer sends: 00 03 00 00 00 01 85 DB

DO meter returns: 00 03 02 00 00 85 84

Return command annotation:

00 is the address of slave device, which can be set in the instrument;

03 is the function code, reading and holding register;

02 is the length of data of returned DO value, 2 bytes;

02 is the returned PH value 686 (hexadecimal high byte);

00 00 is the returned DO value 0.00mg/L, to be divided by 100 to get the current DO value. Range: 0.00-20.00mg/L;

85 84 is the CRC16 check code, which changes along with the previous data;

Example of temperature reading:

Computer sends: 00 03 00 01 00 01 D4 1B

DO meter returns:00 03 02 00 FA 05 C7

Return command annotation:

00 is the address of slave device, which can be set in the instrument;

03 is the function code, reading and holding register;

02 is the length of data of returned temperature value, 2 bytes;

02 is the returned PH value 686 (hexadecimal high byte);

00 FA is the returned temperature value 25.0°C (unit: °C), to be divided by 10 to get the current DO value. Range: -10.0 - 60.0°C;

05 C7 is the CRC16 check code, which changes along with the previous data;

Chapter 7 Failure Analysis & Trouble-shooting

1. No display on controller?

A: Check if the power cable is correctly connected, power is on.

2. Number in display is jumping up and down?

A: Check if there is any interference equipment such as frequency converter is nearby. The instrument should be kept away from such interference equipment or protected with good shielding measures.

3. The response of number is slow?

A: If the electrode is covered by dirt, the response would be slow. Clean the pollutant in a corresponding method. A slow response is normal in winter.

Appendix

The data source is HJ506—2009 national environment protection standard.

Temp / °C	Solubility (mg/L) of oxygen under pressure (101.325k Pa)	Correction value [(mg/L)/(g/Kg)] when the salt content is increased by 1g/Kg.	Temp / °C	Solubility (mg/L) of oxygen under pressure (101.325k Pa)	Correction value [(mg/L)/(g/Kg)] when the salt content is increased by 1g/Kg.
0	14.62	0.0875	21	8.91	0.0464
1	14.22	0.0843	22	8.74	0.0453
2	13.83	0.0818	23	8.58	0.0443
3	13.46	0.0789	24	8.42	0.0432
4	13.11	0.0760	25	8.26	0.0421
5	12.77	0.0739	26	8.11	0.0407
6	12.45	0.0714	27	7.97	0.0400

7	12.14	0.0693	28	7.83	0.0389
8	11.84	0.0671	29	7.69	0.0382
9	11.56	0.0650	30	7.56	0.0371
10	11.29	0.0632	31	7.43	0.0364
11	11.03	0.0614	32	7.30	0.0354
12	10.78	0.0593	33	7.18	0.0348
13	10.54	0.0582	34	7.07	0.0338
14	10.31	0.0561	35	6.95	0.0332
15	10.08	0.0545	36	6.84	0.0322
16	9.87	0.0532	37	6.73	0.0316
17	9.66	0.0514	38	6.63	0.0306
18	9.47	0.0500	39	6.53	0.0300
19	9.28	0.0489	40	6.43	0.0291
20	9.09	0.0475			

Table 1 The function among oxygen solubility, water temp and water salt content

Electric conductivity/ (mS/cm)	Salt content in water/ (g/Kg)	Electric conductivity/ (mS/cm)	Salt content in water/ (g/Kg)	Electric conductivity/ (mS/cm)	Salt content in water/ (g/Kg)
5	3	20	13	35	25
6	4	21	14	36	25
7	4	22	15	37	26
8	5	23	15	38	27
9	6	24	16	39	28
10	6	25	17	40	29
11	7	26	18	42	30
12	8	27	18	44	32
13	8	28	19	46	33

14	9	29	20	48	35
15	10	30	21	50	37
16	10	31	22	52	38
17	11	32	22	54	40
18	12	33	23		
19	13	34	24		

Table 2 The function between electric conductivity and salt content

Temp /°C	Pressure of saturated water steam/ hPa	Temp /°C	Pressure of saturated water steam/ hPa	Temp /°C	Pressure of saturated water steam/ hPa
0	6.1	15	17.1	30	50.2
1	6.6	16	18.1	31	53.2
2	7.1	17	19.3	32	56.2
3	7.6	18	20.7	33	59.4
4	8.1	19	22.0	34	62.8
5	8.7	20	28.1	35	66.2
6	9.3	21	29.9	36	69.8
7	10.0	22	31.7	37	73.4
8	10.7	23	33.6	38	77.2
9	11.5	24	35.6	39	81.0
10	12.3	25	37.7	40	85.0
11	13.1	26	40.0		
12	14.0	27	42.4		
13	14.9	28	44.9		
14	16.0	29	47.6		

Table 3 The function between pressure of saturated water steam and temp

Altitude h/m	Average atmospheric pressure p/hPa	Altitude h/m	Average atmospheric pressure p/hPa	Altitude h/m	Average atmospheric pressure p/hPa
0	1013	1900	799	3800	630
100	1001	2000	789	3900	622
200	988	2100	779	4000	614
300	976	2200	769	4100	607
400	964	2300	760	4200	599
500	952	2400	750	4300	592
600	940	2500	741	4400	584
700	928	2600	732	4500	577
800	917	2700	723	4600	570
900	905	2800	714	4700	563
1000	894	2900	705	4800	556
1100	883	3000	696	4900	549
1200	872	3100	687	5000	542
1300	861	3200	679	5100	535
1400	850	3300	670	5200	529
1500	840	3400	662	5300	522
1600	829	3500	654	5400	516
1700	819	3600	646	5500	509
1800	809	3700	638		

Table 4 The corresponding value of average atmospheric pressure and altitude