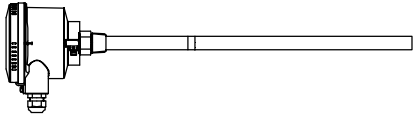

Continuous level measuring system  
**NC 8000**  
 Technical information / Instruction manual

## Table of contents

	Page
Safety Notes / Technical support	2
-----	
Introducion	
Applications / Function / Features	3
-----	
Technical data NC 8100	
	
Dimensions	4
Electrical data	8
Mechanical data	9
Operating conditions	10
Approvals	13
-----	
Mounting	14
-----	
Electrical installation	16
-----	
Operation	17
-----	
Notes for use in Hazardous Locations	22
-----	
Probe Modifications	
Shortening the rope (rope version)	27

Subject to technical change.  
 All dimensions in mm (inch).

We assume no liability for typing errors.  
 Different variations than specified are possible.  
 Please contact our technical consultants.

## Safety notes / Technical support

---

### Notes

- Installation, maintenance and commissioning may be accomplished only by qualified technical personnel.
- The product must be used only in the manner outlined in this instruction manual.
- This product is intended for use in industrial areas. Operation of this equipment in a residential area may cause interference to several frequency based communications.

Special attention must be paid to warnings and notes as follows:

#### WARNING



Relates to a caution symbol on the product: A failure to observe the necessary precautions can result in death, serious injury and/or considerable material damage.

#### WARNING



Relates to a caution symbol on the product: Risk of electric shock

#### WARNING





A failure to observe the necessary precautions can result in death, serious injury and/or considerable material damage.

This symbol is used, when there is no corresponding caution symbol on the product.

#### CAUTION

A failure to observe the necessary precautions can result in considerable material damage.

### Safety symbols

In manual and on product	Description
	CAUTION: refer to accompanying documents (manual) for details.
	Earth (ground) Terminal
	Protective Conductor Terminal

## Introduction

---

### Applications

NC 8000 is a cost-effective instrument for level measurement in applications such as the processing of food and beverages, pharmaceuticals, detergents and pet food. It performs in liquids, bulk solids and slurries, including viscous (conductive or nonconductive) materials, even in challenging environments involving vapour and dust.

- Mining and cement
- Power
- Food and beverage
- Water
- Chemical
- Oil and gas

### Function

NC 8000 is a 2-wire instrument combining a sophisticated, yet easy-to-adjust, microprocessor transmitter with field-proven probes.

The electronic component contains the measurement module (driver) and the microprocessor module. This set of parts forms a calibrated pair that measures process capacitance in pico Farads (pF) which is proportional to the level of material in the tank. An optional safety barrier can be included in the electronic compartment for Hazardous Area applications.

The probe comprises a measurement section and an active shield section that is a fixed length. The probe is the primary system sensor, and it indicates the electrical capacitance value of the measurement section relative to the environment (tank wall, stilling well, or conductive material). This part of the probe connects to the electronic transmitter.

### Features

- Threaded and flanged process connections
- Corrosion resistant construction, PFA, PEEK, and 316L stainless steel wetted parts
- 5 m (16.4 ft) maximum insertion length for rod versions
- 25 m (82 ft) maximum insertion length for rope versions
- Rugged shear and abrasion resistant probe
- Fully adjustable range: level, damping, diagnostics, etc.
- Field adjustable insertion length for rope probes without PFA insulation
- Probe input ESD protected
- Field proven and Active-Shield technology and variable frequency oscillator

## Technical data - Dimensions

### Enclosure

#### NC 8100 Top view

M20x1.5 cable gland

NPT 1/2" conduit

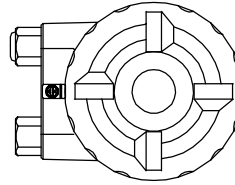
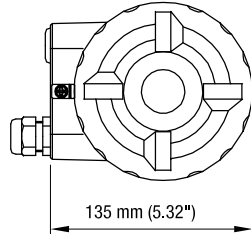

#### NC 8100 Threaded process connection

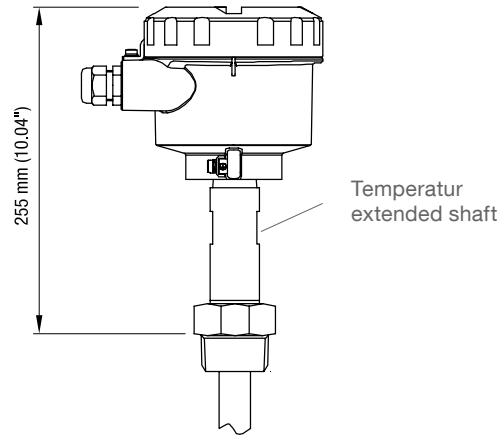
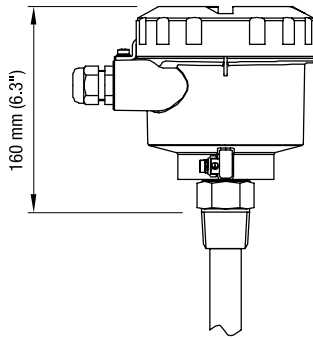

#### NC 8100 Flanged process connection

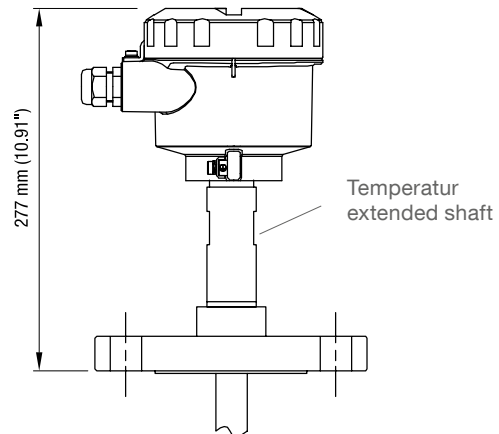
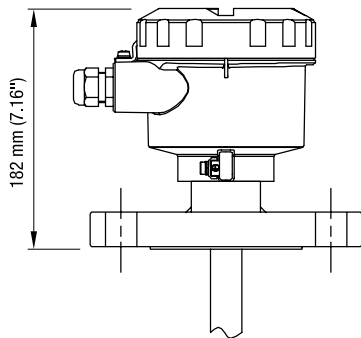

## Dimensions

### NC 8100 Rod version

Threaded process connection

### Continuous level measuring system

**NC 8000**

Flanged process connection

Technical information / Instruction manual

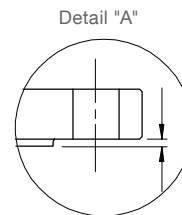
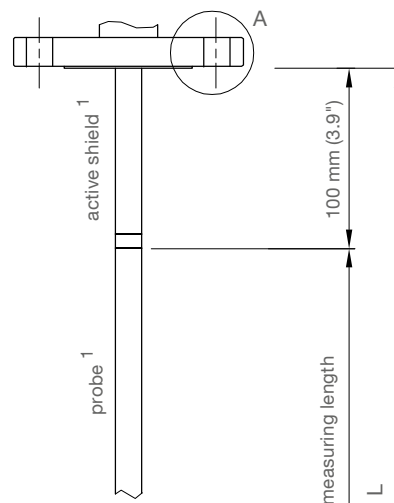
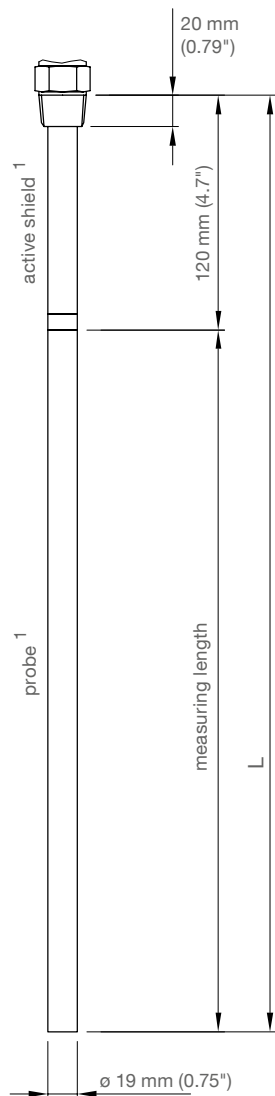

L does not include any raised face (see page 7)

<sup>1</sup> Active shield and probe is PFA coated

## Dimensions

### NC 8100 Rope version

Rope not PFA coated

Rope PFA coated

Applicable for isolating (non conductive) media only

Threaded process connection

Threaded process connection

Flanged process connection

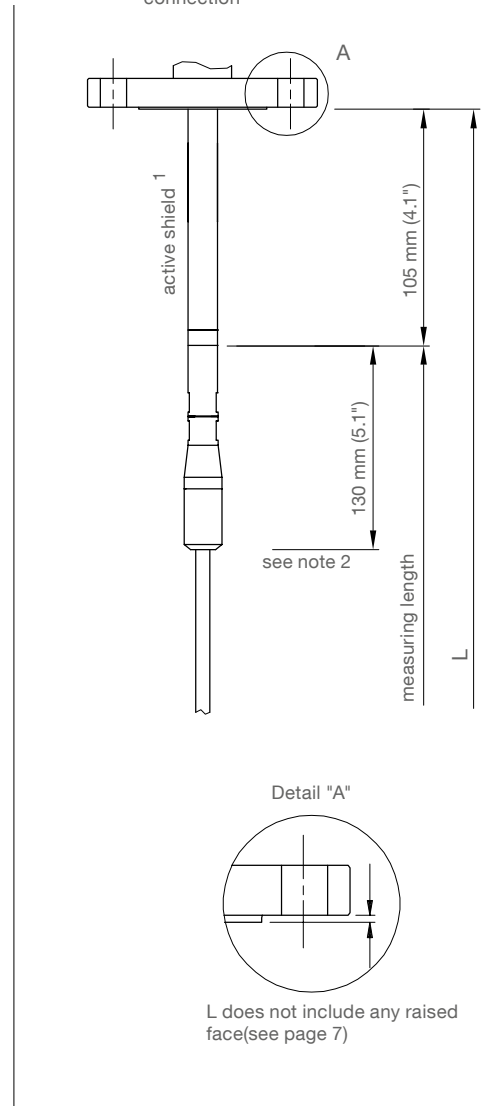
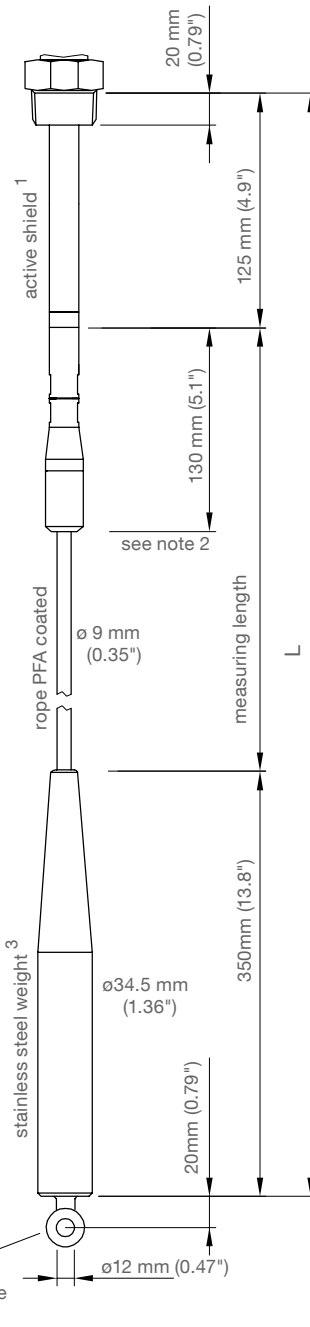
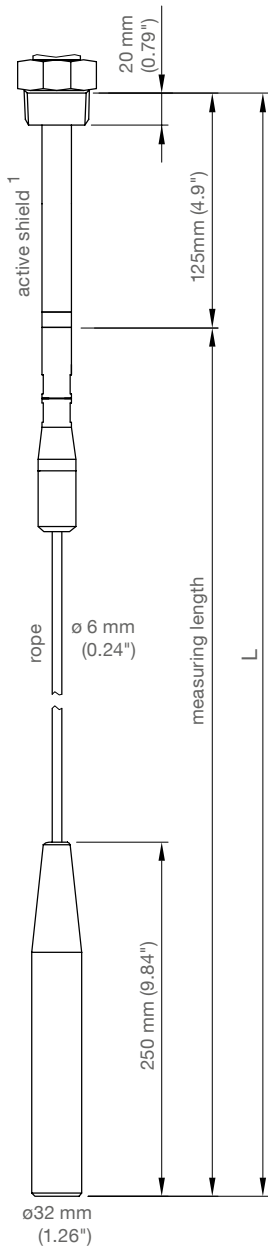

<sup>1</sup> Active shield is PFA coated

<sup>2</sup> For version with PFA coated rope:

For conductive materials, the measuring length includes the exposed PFA coated rope only. Any fluid contact with the upper rod assembly (level above PFA rope) will result in a short circuit and incorrect readings.

<sup>3</sup> Weight is electrically isolated from rope, but not PFA coated

## Dimensions

### Flanges

Continuous level measuring system

### NC 8000

	Code	Type	Number of holes	Technical information / Instruction manual			
				d2 mm (inch)	Lk mm (inch)	D mm (inch)	thickness mm (inch)
ASME B16.5, raised face	5A	1" 150 lbs	4	15.9 (0.63)	79.3 (3.12)	108.0 (4.25)	14.3 (0.56)
	5B	1" 300 lbs	4	19.1 (0.75)	88.9 (3.5)	123.8 (4.87)	17.5 (0.69)
	5C	1" 600 lbs	4	19.1 (0.75)	88.9 (3.5)	123.8 (4.87)	17.5 (0.69)
	5D	1½" 150 lbs	4	15.9 (0.63)	98.6 (3.88)	127.0 (5.0)	17.5 (0.69)
	5E	1½" 300 lbs	4	22.2 (0.87)	114.3 (4.5)	155.6 (6.13)	20.6 (0.81)
	5F	1½" 600 lbs	4	22.2 (0.87)	114.3 (4.5)	155.6 (6.13)	22.4 (0.88)
	5G	2" 150 lbs	4	19.1 (0.75)	120.7 (4.75)	152.4 (6.01)	19.1 (0.75)
	5H	2" 300 lbs	8	19.1 (0.75)	127.0 (5.0)	165.1 (6.5)	22.2 (0.87)
	5J	2" 600 lbs	8	19.1 (0.75)	127.0 (5.0)	165.1 (6.5)	25.4 (1.0)
	5K	3" 150 lbs	4	19.1 (0.75)	152.4 (6.01)	190.5 (7.5)	23.9 (0.94)
	5L	3" 300 lbs	8	22.2 (0.87)	168.2 (6.62)	209.6 (8.25)	28.6 (1.13)
	5M	3" 600 lbs	8	22.2 (0.87)	168.2 (6.62)	209.6 (8.25)	31.7 (1.25)
	EN 1092-1 type A, flat faced	6A	DN25 PN16	4	14.0 (0.55)	85.0 (3.35)	115.0 (4.53)
6B		DN25 PN40	4	14.0 (0.55)	85.0 (3.35)	115.0 (4.53)	18.0 (0.71)
6C		DN40 PN16	4	18.0 (0.71)	110.0 (4.33)	150.0 (5.91)	18.0 (0.71)
6D		DN40 PN40	4	18.0 (0.71)	110.0 (4.33)	150.0 (5.91)	18.0 (0.71)
6E		DN50 PN16	4	18.0 (0.71)	125.0 (4.92)	165.0 (6.5)	18.0 (0.71)
6F		DN50 PN40	4	18.0 (0.71)	125.0 (4.92)	165.0 (6.5)	20.0 (0.79)
6G		DN80 PN16	8	18.0 (0.71)	160.0 (6.3)	200.0 (7.87)	20.0 (0.79)
6H		DN80 PN40	8	18.0 (0.71)	160.0 (6.3)	200.0 (7.87)	24.0 (0.94)
6J		DN100 PN16	8	18.0 (0.71)	180.0 (7.09)	220.0 (8.66)	20.0 (0.79)
6K		DN100 PN40	8	22.0 (0.87)	190.0 (7.48)	235.0 (9.25)	24.0 (0.94)

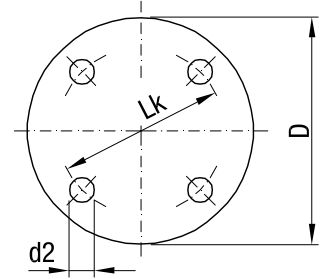

Raised face

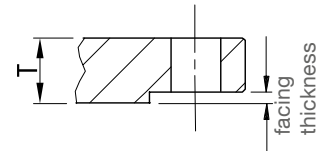

Type	Facing thickness
ASME 150 lb	2 mm (0.08")
ASME 300 lb	
ASME 600 lb	7 mm (0.28")

## Technical data - Electrical data

---

### Power / Output

Supply voltage 12-30 V DC any polarity, 2-wire current loop circuit,  
 max. resistance value 550 Ω @ 24 V DC

---

Ex approvals Max. voltage which does not invalidate the intrinsically safe protection of the sensor  
 (probe):  $U_m = 250V$  AC

---

Measurement signal Current loop 4 – 20 mA or 20 – 4 mA according to NAMUR NE 43

### Performance

Measurement range 1.66 pF to 3300 pF

---

Minimum span 3.3 pF

---

Accuracy < 0.5% of actual measurement value

---

Non-linearity and reproducibility < 0.4% full scale and actual measurement value

---

Temperature stability max. temperature drift of 0.25% of actual capacitance value

---

Safety

- current signaling according to NAMUR NE 43, signal 3.8 to 20.5, fault  $\leq 3.6$  or  $\geq 21$  mA (22 mA)
- probe input ESD protected
- inputs/outputs fully galvanically isolated
- polarity-insensitive current loop

---

Diagnostics

- measurement limits
- failure in measurement circuit
- memory check sum
- system watch dog

See Fault Values on page 20 for detailed descriptions of Diagnostic messages

### User interface

Local LCD Display 4–digit (each digit can be 0 to 9 or limited alpha characters)

---

Rotary switch and Push buttons Menu setting and calibration



## Technical data - Mechanical data

Process connections		Continuous level measuring system
Threaded rod mounting	3/4", 1", 1 1/2" (NPT) (Taper)	ANSI/ASME B1.20.1
	R 3/4", 1", 1 1/2" (BSPT)	EN 10226; PT (JIS-T), JIS B 0203
	G 3/4", 1", 1 1/2" (BSPP)	EN ISO 228-1; PF (JIS-P), JIS B 0202
Threaded rope mounting	1 1/2" NPT (Taper)	ANSI/ASME B1.20.1
	R 1 1/2" (BSPT)	EN 10226; PT (JIS-T), JIS B 0203
	G 1 1/2" (BSPP)	EN ISO 228-1; PF (JIS-P), JIS B 0202
Flange mounting	1 to 4" NPS	ASME B16.5
	DN 25 to 100	EN 1092-1
<b>Probe</b>		
Material wetted parts	1.4404 (316L)/PEEK/PFA Rope probe without PFA coating applicable for isolating (non conductive) media only. FKM or FFKM O-ring	
Tensile (max)	Rod probe: horizontal tensile load 30 Nm Rope probe: 1.900kg (4,188 lbs)	
<b>Enclosure</b>		
Termination	Removable terminal block, 2.5 mm <sup>2</sup> max.	
Construction	Powder-coated aluminum with gasket	
Optional thermal isolator	1.4404 (316L) stainless steel	
Cable entry	2 x M20 thread (option: 1 x 1/2" NPT thread with adaptor)	
	With ATEX approval: - Default: 2x M20x1.5 - With selection of option Pos.33a: 2x NPT 1/2" tapered ANSI B1.20.1	
Ingress protection	Type 4 / NEMA 4 / IP65 standard, IP68 optional	
	Note: The use of approved watertight conduit hubs/glands is required for Type 4 / NEMA 4, Type 6 / NEMA 6, IP68 (outdoor applications).	
Separation between Zone 0 and Zone 1 (ATEX II 1/2G)	Material of the separation element (partition wall) - Stainless steel, 1.4404 (316L) - Glass, Inocell 600 (Glass seal)	

## Weight

Depends on configuration

## Technical data - Operating conditions

---

### Environmental

Location	Indoor/outdoor
Altitude	2,000 m max.
Ambient temperature	- 40 to +85°C (- 40 to +185°F)  With ATEX approval: Depending on Surface Temperature and Temperature Class, details see page 26.
Relative humidity	Suitable for outdoors (Type 4/NEMA 4/IP65 enclosure, IP68 optional)
Installation category	I
Pollution degree	4

### Process

Note: Not recommended for direct steam contact

Pressure range	-1 to 35 bar g (-14.6 to 511 psi g) See Pressure versus temperature curves below
Temperature range	Without temperature extended shaft: -40 to 85°C (-40 to 185°F) -20 to 85°C (-4 to +185°F) with option FFKM seal O-ring With temperature extended shaft: -40 to 200°C (-40 to 392°F) -20 to 200°C (-4 to +392°F) with option FFKM seal O-ring  With ATEX approval: Depending on Surface Temperature and Temperature Class, details see page 26.
Min. relative dielectric constant	1.5

## Technical data - Operating conditions

### Pressure versus temperature curves

All versions, threaded

Continuous level measuring system

**NC 8000**

Technical information / Instruction manual

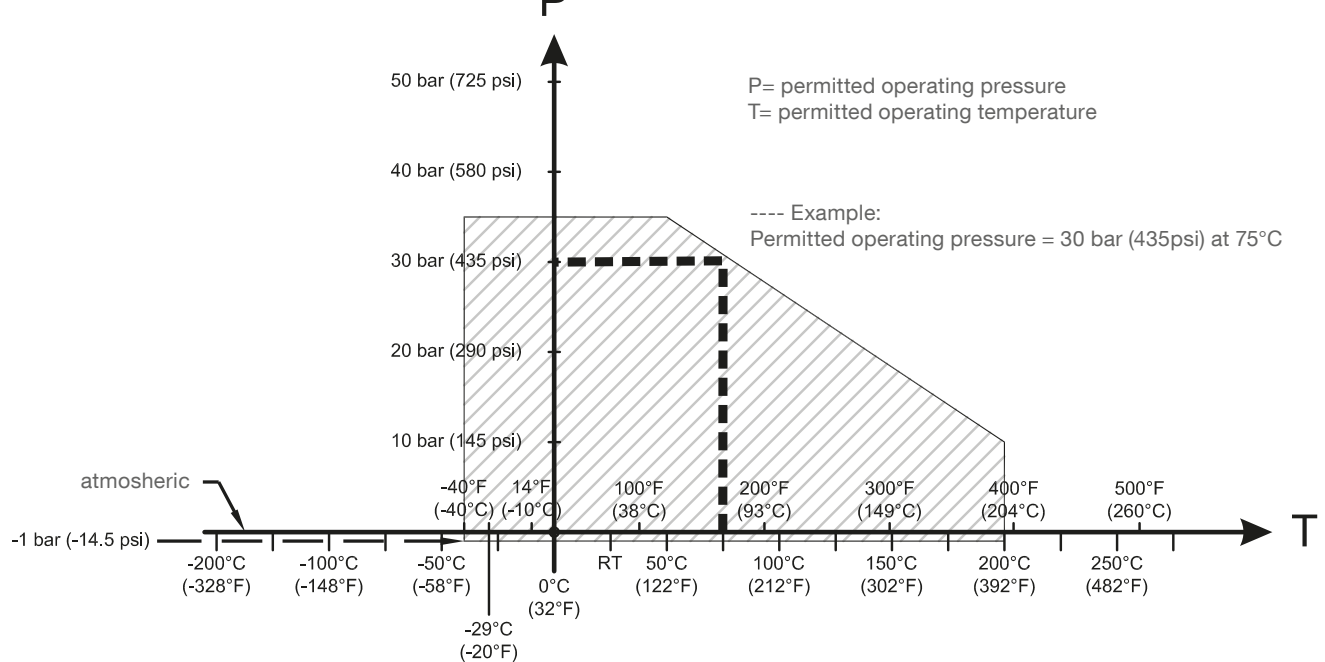

All versions, ASME flanged

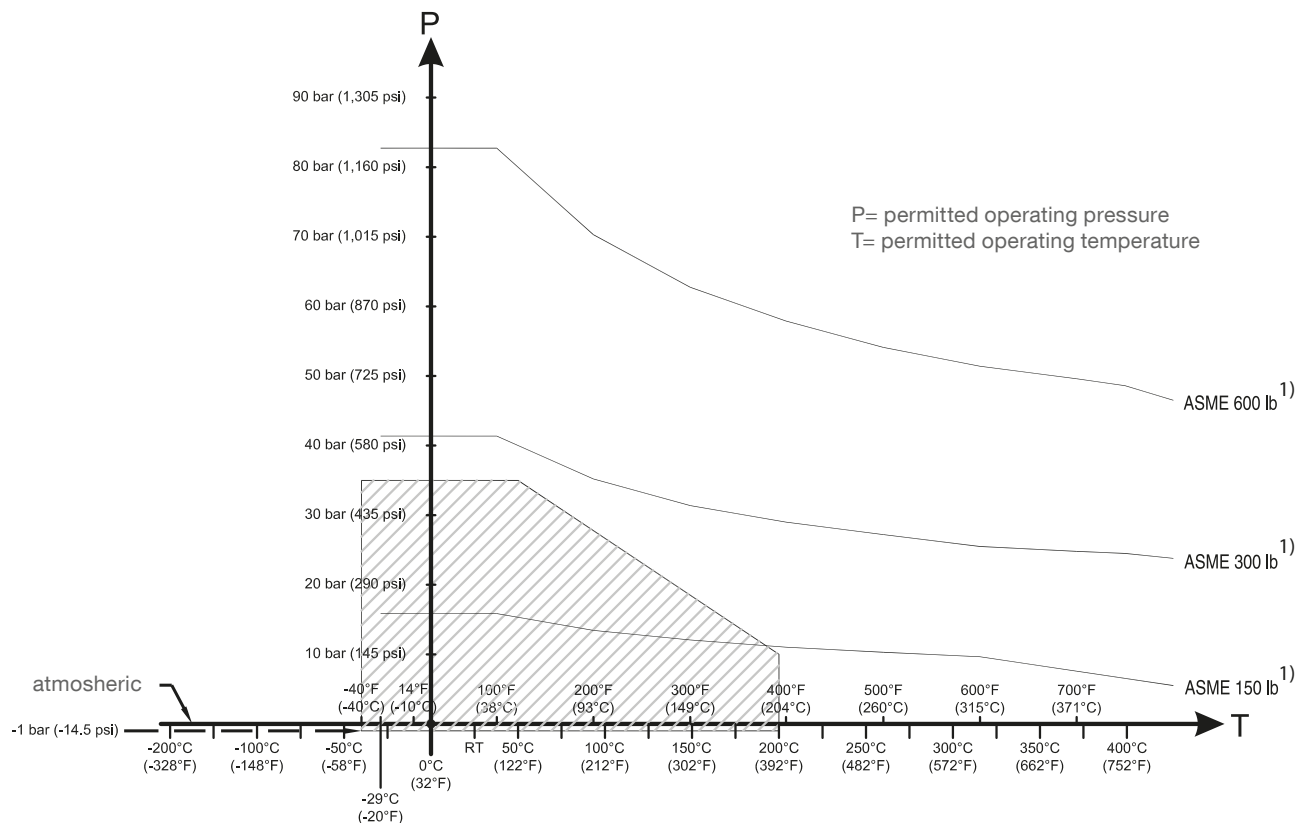

1) The curve denotes the minimum allowable flange class for the shaded area below.

## Technical data - Operating conditions

All versions, EN flanged

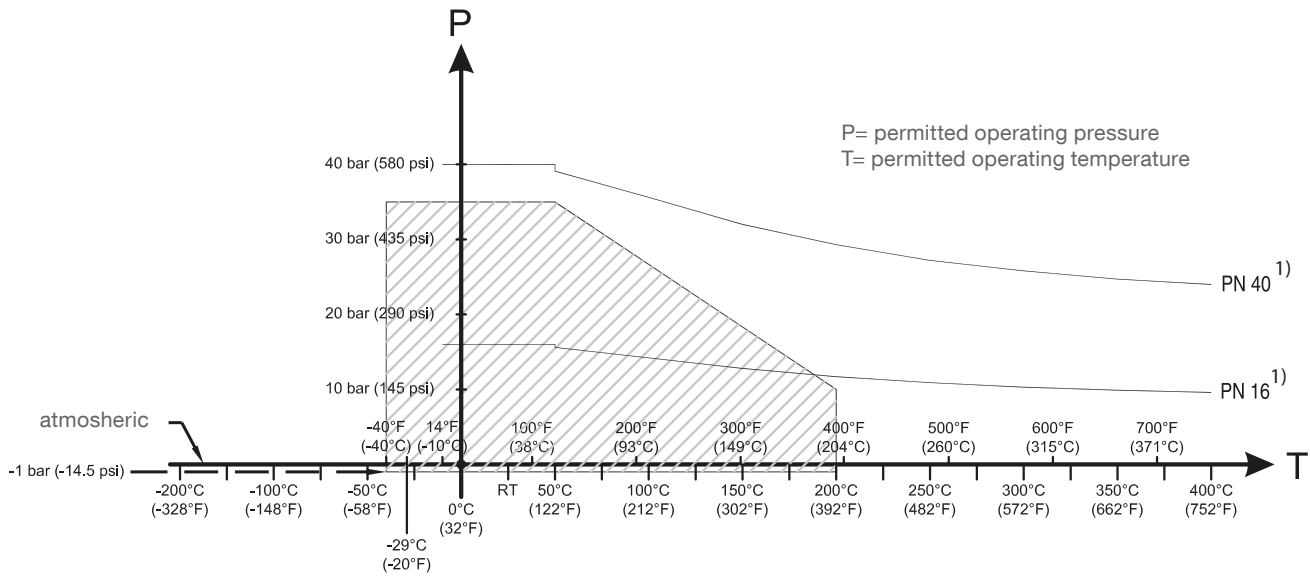

1) The curve denotes the minimum allowable flange class for the shaded area below.

## Approvals

---

General Purpose	CE, CSA, FM, TR-CU Continuous level measuring system
Dust Ignition Proof	<b>NC 8000</b> ATEX II 1/2 D Technical Information / Instruction manual
Flame Proof / Explosion Proof	ATEX II 1/2 G Ex d[ja] IIC CSA/FM Class I, Div. 1, Gr. A, B, C, D TR-CU INMETRO
Marine	Lloyds Register of Shipping, Categories ENV1, ENV2 and ENV5

Pressure Equipment  
Directive 2014/68/EU

NC 8000 units have no pressure-bearing housing of their own, and therefore do not come under the Pressure Equipment Directive as pressure nor safety accessories (see EU Commission Guideline 1/8 and 1/20).

## Mounting

### ! General Safety Instructions

- Installation shall be performed only by qualified personnel and in accordance with local governing regulations.
- This device is to be used only in the manner outlined in this manual. Otherwise, protection provided by the device may be impaired.
- Materials of construction are chosen based on their chemical compatibility (or inertness) for general purposes. For exposure to specific environments, check with chemical compatibility charts before installing.
- The user is responsible for the selection of bolting and gasket materials which will fall within the limits of the flange and its intended use, and which are suitable for the service conditions
- Refer to the device nameplate for approval information.
- This product is susceptible to electrostatic shock. Follow proper grounding procedures.
- Before inserting the instrument into its mounting connection, check to ensure the threads are matching to avoid damaging them.
- Cable entry devices and closing elements of unused apertures must meet a temperature range from min. -40°C to 10 K above max. ambient temperature.

#### Pressure applications

- Never attempt to loosen, remove or disassemble process connection or instrument housing while vessel contents under pressure.
- Improper installation may result in loss of process pressure.
- For pressure applications, use PTFE tape or other appropriate thread sealing compound and tighten the process connection beyond hand-tight.
- NC 8000 units are pressure tested, meeting or exceeding the requirements of the ASME Boiler and Pressure Vessel Code and the European Pressure Equipment Directive.

#### Rope tensile strength

- Do not exceed the tensile strength of the rope at 1900 kg/ 4188 lbs.
- Always confirm that the load carrying capability of the silo/tank roof is sufficient to withstand the actual force on the rope conditions, especially where the force will be, or could be, as great as 1900 kg/4188 lbs. A rope probe with a PFA jacket reduces the amount of possible product build-up on the probe as well as the tensile force on the rope.

### ! Additional Safety Instructions for Hazardous Locations

see page 22ff

## Handling Precautions

! To prevent damage, all units with a rod longer than 2 m (6.5 ft) must be handled as described below.

When lifting NC 8000 from a horizontal position, support it at these three points:

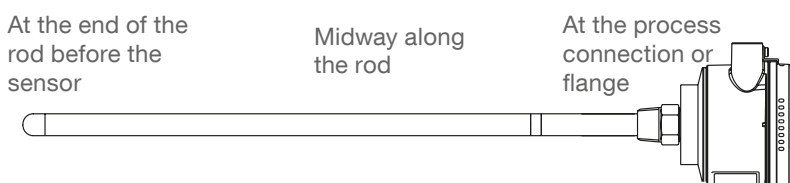

Once vertical, NC 8000 may be held by the process connection or flange:

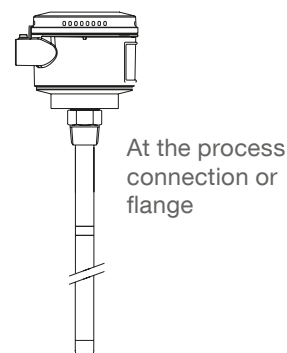

## Mounting

### Mounting

Continuous level measuring system

#### NC 8000

Technical information / Instruction manual

- NC 8000 is normally mounted on the vessel top
- Before inserting the instrument into its mounting connection, check to ensure the threads are matching to avoid damaging them. Simply screw the instrument into the process connection and tighten.

#### Rope version:

- The rope version is designed for top mounting. The rope suspends vertically so that it reaches into the process with the end of the rope being the start of the measurement (dependent on probe option).
- Non-insulated rope version:  
For non-conductive applications only. Weight is included in measuring length.
- PFA insulated rope version:  
For conductive materials, the measuring length includes the exposed PFA insulated rope only. Any fluid contact with the upper rod assembly (level above PFA rope, see page 6) will result in a short circuit and incorrect readings.

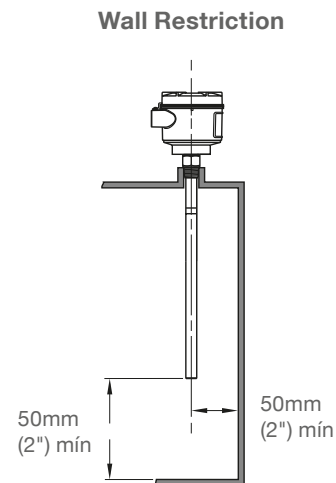
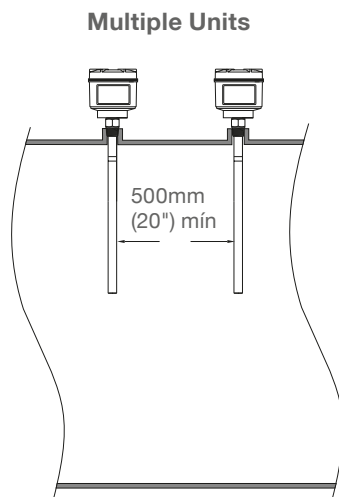

### Process cautions for solids

**! In Hazardous Locations: Observe Specific condition of use for electrostatic charge (see page 24)**

Keep unit out of path of falling material.

Consider material surface configuration when installing unit.

Tensile load must not exceed probe or vessel rating.

Note: Buildup of material or condensation in active shield area does not affect operation.

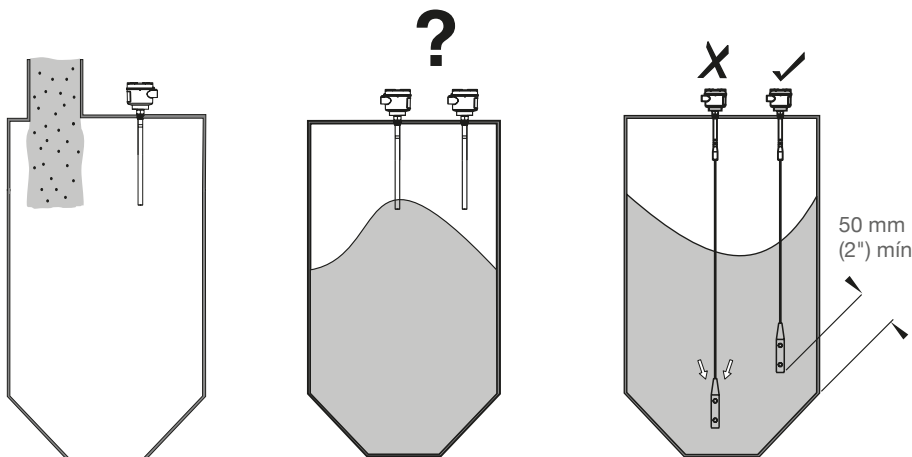

## Electrical installation

### ! General Safety Instructions

- Check the device nameplate and process device tag to verify the approval rating.
- Use appropriate conduit seals to maintain IP or NEMA rating.
- The sensor terminal block connects the electronics to the measurement module, providing the supply voltage and receiving the frequency signal from the measurement. The user should not alter these connections.

### ! Additional Safety Instructions for Hazardous Locations

see page 22ff

## Wiring

With internal safety barrier*	Without internal safety barrier
white (S)	orange (S)
black (0)	black (0)
red (+)	red (+)

\* For intrinsically safe connection to the probe

**Power supply / Signal output:**  
 12 to 30 V DC  
 2-wire current loop 4-20mA  
 max. resistance value 550 Ω @ 24 V DC

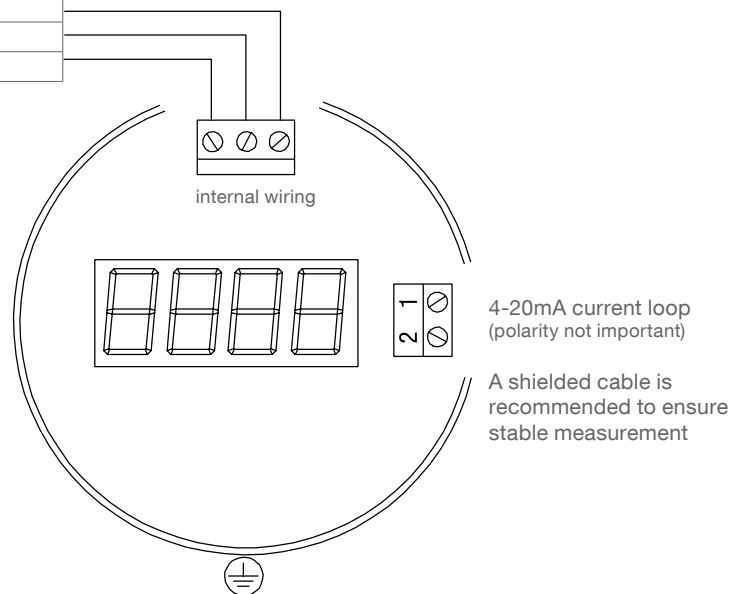

1. Loosen the retaining lid clip and remove the enclosure cover.
2. Loosen the cable gland and thread the cable through it.
3. Connect the power/signal conductor wires to the current-loop terminal blocks (any polarity). The loop voltage must be between 12 and 30 V DC.
4. Ground the enclosure by connecting the housing and the process connection with either the stilling well and/or the tank wall, using the ground lug near the bottom of the housing.
5. Check that all connections are secure.
6. Replace enclosure cover and tighten retaining lid clip.

Connect protective earth wire to terminal provided in housing and marked with

Use crimp type cable socket for 4 mm screw diameter, ring form or U-form (e. g. DIN 46234).



### User interface

Continuous level measuring system

NC 8000

The user interface comprises the liquid crystal display (LCD), the 6-position rotary switch, and two push-buttons. Select a menu using the rotary switch; select and/or alter a read-out or value using the push-buttons.

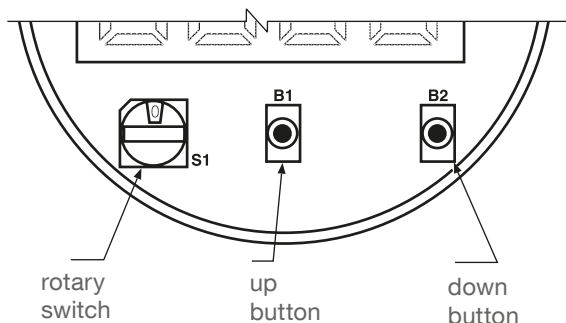

The rotary switch can be set from 0 to 5. Each position represents a menu. The position wraps from 5 to 0. The LCD (liquid crystal) displays settings altered by the rotary switch and the pushbuttons.

### Menu functions

Menu (Rotary switch position)	0	1	2	3	4	5
<b>Display</b>	Actual measured value (pF)	Lower Range Value LRV (pF)  Related to: 0% level/ 4mA	Upper Range Value URV (pF)  Related to: 100% level/ 20mA	Actual loop-current (mA)	Diagnostics	Damping
<b>Up button</b>		Increase LRV	Increase URV	Set fault protection to 22 mA	Product version	Increase damping
<b>Down button</b>		Decrease LRV	Decrease URV	Set fault protection to 3.6 mA		Decrease damping
<b>Both buttons</b>		The actual measured value is set as LRV	The actual measured value is set as URV	Disable fault protection	Reset/Acknowledge Fault	Set damping to 1.00

When you turn the rotary switch, the LCD shows the new menu selection for about 1 second followed by the data for that selection. When you alter a read-out or value, a colon (:) is displayed when the debounce delay timer has expired and the new value has been accepted.

Menu positions 0 and 3 are the recommended positions during normal operation.

## Operation

### Menu position 0

#### Actual measurement (pF)

<b>Display</b>	<ul style="list-style-type: none"> <li>• LCD displays the actual measurement in pF.</li> <li>• In case of a system fault, the display alternates between actual measurement and "Fit". View the fault details in menu 4.</li> <li>Pressing either or both push-buttons in menu 0 has no effect.</li> </ul>
----------------	--

### Menu position 1

#### Lower Range Value (pF), related to 0% level/ 4mA

<b>Display</b>	<ul style="list-style-type: none"> <li>• LCD displays the Lower Range Value (LRV) in pF, occurring when the range is at 0% and the loop-current is set to 4 mA.</li> </ul>
<b>Up button</b>	Increases the Lower Range Value (LRV) Each time you press the button increases the value by the setted step size (initial is 0.01pF) To change the step size: see note below
<b>Down button</b>	Decreases the Lower Range Value (LRV) Each time you press the button decreases the value by the setted step size (initial is 0.01pF) To change the step size: see note below
<b>Both buttons</b>	<ul style="list-style-type: none"> <li>• Pressing both buttons for more than 1 second sets the Lower Range Value (LRV) to the actual measured value.</li> </ul>

### Menu position 2

#### Upper Range Value (pF), related to 100% level /20mA

<b>Display</b>	<ul style="list-style-type: none"> <li>• LCD displays the Upper Range Value (URV) in pF, occurring when the range is at 100% and the loop-current is set to 20 mA.</li> </ul>
<b>Up button</b>	Increases the Upper Range Value (URV) Each time you press the button increases the value by the setted step size (initial is 0.01pF) To change the step size: see note below
<b>Down button</b>	Decreases the Upper Range Value (URV) Each time you press the button decreases the value by the setted step size (initial is 0.01pF) To change the step size: see note below
<b>Both buttons</b>	<ul style="list-style-type: none"> <li>• Pressing both buttons for more than 1 second sets the Upper Range Value (URV) to the actual measured value.</li> </ul>

#### Change the step size

The step size can be set to:      To change the step size:

<b>pF</b>	<b>display</b>
0.1	U0:1
1	U:1
10	U:10
100	U1:00
1000	U1:E3

- Hold the Up or Down buttons for more than 1 second and continue to hold the button until the required step size is displayed
- When no button is pressed for 4 seconds, the step size decreases to the next smallest value.

## Operation

Menu position 3

Continuous level measuring system

**Actual loop current (mA)**

**NC 8000**

Position 3 displays the loop current that is actually present. [Technical information / Instruction manual](#)

The Up and Down buttons set the system fault protection settings (according to NAMUR NE 43). System fault protection is used by control equipment to determine whether or not the NC 8000 is presenting a reliable signal.

When a system fault occurs:

Position 3 fault protection setting	Menu 3 LCD display	Current signal	Menu 0 reading
C:Hi	22 mA	22 mA	pF reading alternating with FLT
C:Lo	3.6 mA	3.6 mA	
C:An	mA value at time of fault	none	pF reading

<b>Display</b>	<p>LCD shows the loop current that is actually present.</p> <ul style="list-style-type: none"> <li>The mA values varies between 3.8 mA (lower saturation point) and 20.5 mA (upper saturation point).</li> <li>When the reading goes above the URV or below the LRV but still within the measurement range of the unit, it will remain at 20.5 or 3.8 respectively until the level returns between URV and LRV.</li> </ul>
<b>Up button</b>	<ul style="list-style-type: none"> <li>Pressing the Up button for less than 1 second shows the system fault protection setting.</li> <li>Holding the Up button for longer than 1 second will change the fault protection setting to C:Hi. <sup>a</sup></li> </ul>
<b>Down button</b>	<ul style="list-style-type: none"> <li>Pressing the Down button for less than 1 second shows the system fault protection setting.</li> <li>Holding the Down button for longer than 1 second will change the fault protection setting to C:Lo.</li> </ul>
<b>Both buttons</b>	<ul style="list-style-type: none"> <li>Pressing both buttons for more than 1 second disables the system fault protection and the LCD will read C:An.</li> </ul>

<sup>a</sup>. System errors that would trigger a fault are a checksum error, an absence of measurement signal, or a measurement beyond 1.66 pF (low) or 3300 pF (high).

Menu position 4

### Diagnostics

<b>Display</b>	<ul style="list-style-type: none"> <li>LCD shows diagnostic information. A correctly operating device shows 0.00 on the LCD. See chart below for explanation of system fault values.</li> </ul>
<b>Up button</b>	<ul style="list-style-type: none"> <li>LCD shows revision information. Please note this information when calling manufacturer for assistance.</li> </ul>
<b>Both buttons</b>	<ul style="list-style-type: none"> <li>Holding both buttons for more than 1 second will try to reset the error status. The LCD reads 0.00 when the status has been successfully reset. Monitor the NC 8000 more closely after a diagnostic error has occurred.</li> </ul>

## Operation

### Fault values

128	The device is in calibration mode. The measurement values and the loop-current setting may no longer be trusted.
64	A checksum error has occurred in the program and/or data memory. The measurement values and the loop-current setting may no longer be trusted.
32	NC 8000 system watchdog has been activated. This fault can be combined with fault 64, resulting in fault 96. The measurement values and the loop-current setting may no longer be trusted.
8	An arithmetic error has occurred, perhaps caused by an incorrect value setting. This event type error will rarely affect the operation of the NC 8000.
4	An error occurred while trying to store settings in the local nonvolatile memory. The NC 8000 may not operate correctly.
2	The measurement has exceeded the device limits (1.66 pF and 3300 pF). Check that the probe is correctly connected to the measurement module.
1	The measurement circuit no longer emits signal. Check the wiring to/from the measurement module or barrier circuit.

**Note:** It is possible for more than one fault to occur at the same time. The display will read the combined result of both fault values. For example: If fault value 1 and fault value 2 occur together, the display will read fault value 3. If the display reads fault value 10, it means fault value 8 and fault value 2 have occurred together.

### Menu position 5

#### Damping

<b>Display</b>	<ul style="list-style-type: none"> <li>LCD shows the damping value. The damping value alters the delay at which the display and the loop current will follow the measured capacitance from the probe.</li> </ul> <p>Rough indication:                  Assuming that an immediate capacitance change on the probe rises the loop current from 4mA to 13mA. Depending on the damping value the loop current takes a delay as stated below to rise to 8,5mA (50% of the total rise to 13mA):</p> <table> <thead> <tr> <th>Setted damping value</th> <th>Delay to reach 8,5mA</th> </tr> </thead> <tbody> <tr> <td>10</td> <td>&lt; 1sec</td> </tr> <tr> <td>50</td> <td>2 sec</td> </tr> <tr> <td>100</td> <td>3 sec</td> </tr> <tr> <td>500</td> <td>10 sec</td> </tr> <tr> <td>1000</td> <td>17 sec</td> </tr> <tr> <td>5000</td> <td>90 sec</td> </tr> </tbody> </table>	Setted damping value	Delay to reach 8,5mA	10	< 1sec	50	2 sec	100	3 sec	500	10 sec	1000	17 sec	5000	90 sec
Setted damping value	Delay to reach 8,5mA														
10	< 1sec														
50	2 sec														
100	3 sec														
500	10 sec														
1000	17 sec														
5000	90 sec														
<b>Up button</b>	<ul style="list-style-type: none"> <li>Pressing Up button for less than 1 second increases the damping value in 0.01 steps. Damping can be set to any value from 1.0 to 9999</li> <li>Holding the Up or Down buttons for more than 1 second increases the step size to 0.1. If you continue to hold the button, the step size increases to 10, 100, and 1000 (displayed as 1E3). When no button is pressed for 4 seconds, the step size decreases to the next smallest value. At each step size, press the buttons for less than 1 second to adjust the value.</li> </ul>														
<b>Down buttons</b>	<ul style="list-style-type: none"> <li>Pressing Down button for less than 1 second decreases the damping value in 0.01 steps. Damping can be set to any value from 1.0 to 9999.</li> <li>When held for more than 1 second, the Down Button will increase the step size by 0.1, 10, 100, and 1000. When no button is pressed for 4 seconds, the step size decreases to the next smallest value. At each step size, press the buttons for less than 1 second to adjust the value.</li> </ul>														
<b>Both buttons</b>	<ul style="list-style-type: none"> <li>Holding both buttons for more than 1 second sets the damping value back to 1.0 (default).</li> </ul>														

## Operation

---

### Start up

Continuous level measuring system

#### NC 8000

Setting Lower Range Value (LRV) Technical information / Instruction manual

- **If probe is fully uncovered in application (0% level is present):**

Set rotary switch to Menu Position 1  
Set LRV by pressing both buttons for more than 1 second.  
The actual measured value is now related to 4mA

---

### Setting Upper Range Value (URV)

- **If probe is fully covered in application (100% level is present):**

Set rotary switch to Menu Position 2  
Set URV by pressing both buttons for more than 1 second.  
The actual measured value is now related to 20mA

- **If probe is not fully covered:**

This procedure is possible with cylindric vessels only (linear relation between level and capacitance)  
Set to your application based on the following example:

LRV (0% level) was set to 12.5 pF

Actual measurement is at 45% of the measurement length of probe:  
Menu Position 0 reads 37 pF

Calculate URV (100% level) as follows:

$$\begin{aligned} \text{URV} &= \frac{[(\text{Actual measurement} - \text{LRV}) * 100 / \text{actual measurement in \%}] + \text{LRV}}{1} \\ &= \frac{[(37 - 12.5) * 100 / 45] + 12.5}{1} \\ &= 66.94 \text{ pF} \end{aligned}$$

Set rotary switch to Menu Position 2 and adjust to 66.94

When calculating the URV, best results are achieved when using the highest possible actual level.

---

### Recommissioning

The NC 8000 should be recommissioned whenever the transmitter or probes are replaced.  
The procedure is similar to procedure "Start up", see above.

---

### Maintenance

NC 8000 requires no regular maintenance or cleaning.

Note: Build-up of material on the active shield area has little or no effect on the performance of the NC 8000.

### Unit repair and excluded liability

All changes and repairs must be done by qualified personnel, and applicable safety regulations must be followed.  
Please note the following:

- The user is responsible for all changes and repairs made to the device.
- All new components must be provided by the manufacturer.
- Restrict repair to faulty components only.
- Do not re-use faulty components.

## Notes for use in Hazardous Locations

---

### Use of this Manual

For use and assembly, refer to the instructions in this Manual. It does contain all instruction as required by ATEX Directive 2014\_34\_EU, Annex II, 1/0/6 and Ordinance INMETRO n° 179/2010

---

### General notes

Refer to appropriate certificate for application in specific hazardous environment.

The equipment has not been assessed as a safety related device (as referred to by Directive 2014\_34\_EU Annex II, clause 1.5).

The certificate numbers have an 'X' suffix, which indicates that specific condition of use apply. Those installing or inspecting this equipment must have access to the certificates.

---

### ! Qualification of personnel / Servicing / Repair

Installation and inspection of this equipment shall be carried out by suitably trained personnel in accordance with the applicable code of practice (ABNT NBR IEC/EN 60079-14 and ABNT/NBR IEC/EN 60079-17 in Europe).

Repair of this equipment shall be carried out by suitably trained personnel in accordance with the applicable code of practice (e.g. ABNT NBR IEC/EN 60079-19 within Europe).

Repair of flameproof path is not intended.

Components to be incorporated into or used as replacements in the equipment shall be fitted by suitably trained personnel in accordance with the manufacturer's documentation.

In potentially explosive atmospheres open the enclosure only when NC 8000 is not energized.  
 Turn off power before servicing any device (the transmitter is in operation when the power supply is switched on).  
 In case of removing the unit from vessel, take care of process pressure and material passing the opening.

---

### ATEX: Certificates / List of Standards

Certificate number: DEKRA 18ATEX0046 X

See [www.uwt.de](http://www.uwt.de) for the latest certificates

See EU - Declaration of conformity for the list of standards valid for ATEX certificates

---

### ATEX: Year of manufacturing

Marking on the name plate is done according to IEC 60062 as follows:

Year of manufacturing	2018	2019	2020	2021	2022	2023	2024	2025	2026	2027	2028	2029
Marking code	K	L	M	N	P	R	S	T	U	V	W	X

## Notes for use in Hazardous Locations

### ATEX: Ex-Marking

Continuous level measuring system

#### NC 8000

- Devices with ATEX approval are marked on the name plate as follows.
- If both Flameproof and Dust ignition proof are present on the same nameplate, a tick box  is present where the end user needs to select (mark) the protection method used at the time of installation.

**Dust Ignition Proof** with intrinsically safe output to probe (Typecode Pos.2 W)

II 1/2 D Ex ia/tb [ia Da] IIIC T<sub>200</sub> 130°C...230°C / T85°C...T130°C Da/Db

**Flameproof / Dust Ignition Proof** with intrinsically safe output to probe (Typecode Pos.2 T)

II 1/2 G Ex ia/db [ia Ga] IIC T6...T3 Ga/Gb

II 1/2 D Ex ia/tb [ia Da] IIIC T<sub>200</sub> 130°C...230°C / T85°C...T130°C Da/Db

### ! ATEX: Permitted zones for installation

Devices can be installed as follows:

	Dust applications	Gas applications
	marking Da/Db	marking Ga/Gb
EPL	Db	Gb
Category	2D	2G
Zone	21	1
<hr/>		
EPL	Da	Ga
Category	1D	1G
Zone	20	0

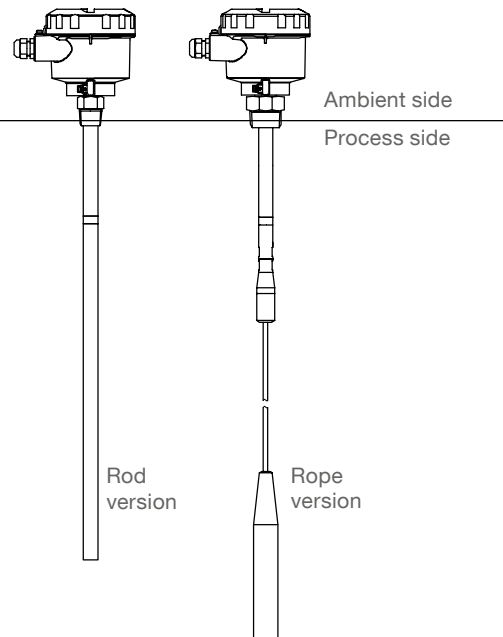

## Notes for use in Hazardous Locations

---

### ! Specific condition of use

**Electrostatic charge** The user shall ensure that the equipment is not installed in a location where it may be subjected to external conditions which might cause a build-up of electrostatic charge on non-conducting surfaces.

---

**Cable entry devices / blanking elements** Dust Ignition Proof:  
 For use in in potentially explosive dust atmospheres:  
 The cable entry devices and the blanking elements of unused apertures shall be of a certified type, suitable for the conditions of use and correctly installed.  
 The minimum ingress protection requirement of IP6X according to EN 60529 must be satisfied.

Flameproof:  
 For use in potentially explosive gas atmospheres:  
 The cable entry devices and the blanking elements of unused apertures shall be of a certified flameproof type, suitable for the conditions of use and correctly installed.

Versions with cable gland mounted by default:  
 The used cable gland is only suitable for fixed installations.  
 The installer is responsible for providing appropriate strain-relief to prevent pulling or twisting.

Versions with blanking element mounted by default:  
 Blanking elements are not to be used with any form of adaptors or reducers.

---

**Flameproof joints** The flameproof joints are not intended to be repaired.

---

**Ambient and process temperature range** Depending on Surface Temperature and Temperature Class, details see page 26.

---

**Max. permitted temperature close to the enclosure** If the process temperature exceeds the max. permissible ambient temperature, the max. resulting temperature close to the enclosure (see dotted line) shall not exceed the related max. permissible ambient temperature (see page 26), taking the worst case conditions into account.  
 This shall be verified by measurement when installed.

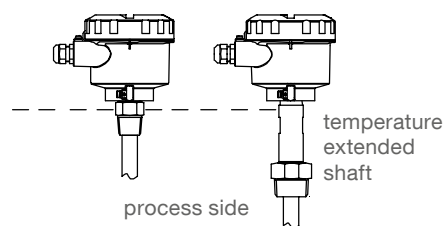



## Notes for use in Hazardous Locations

---

**!** Warnings for installation Continuous level measuring system  
**NC 8000**

**Process pressure** The device construction allows process over-pressure up to 10 or 35 bar (146 or 511 psi). This pressure is allowed for test purposes. The definition of the Ex approvals are only valid for a container-over-pressure between -0.2 .. +0.1 bar (-2.9 .. +1.45 psi). For higher or lower pressures the approvals are not valid.

**Process and ambient temperature** Please check the ambient and process temperatures page 26 for the specific configuration you are about to use or install.

**Chemical resistance against the medium** If the equipment is likely to come into contact with aggressive substances, then it is the responsibility of the user to take suitable precautions that prevent it from being adversely affected, thus ensuring that the type of protection is not compromised. Aggressive substances: e.g. acidic liquids or gases that may attack metals, or solvents that may affect polymeric materials. Suitable precautions: e.g. establishing from the material's data sheet that it is resistant to specific chemicals.

**Versions with cable gland / blanking element mounted by default** Below-mentioned cable diameters and tightening torques of the nut resp. blanking element shall be observed for the installation.

Cable gland M20x1.5 (Dust Ignition Proof)  
Cable diameter: 6 mm to 12 mm  
Tightening torque: Depending on the used cable and therefore to be determined by the user

Cable gland M20x1.5 (Flameproof)  
Cable diameter: Bedding 3.1 mm to 8.6 mm / Overall 6.1 mm to 13.1 mm  
Tightening torque: Number of turns depending on the overall cable diameter of the used cable  
(e. g. 1 turn / cable diameter 12.5 mm to 5.5 turns / cable diameter 6.5 mm)

Blanking element M20x1.5 (all versions)  
Tightening torque: 32.5 Nm

## Notes for use in Hazardous Locations

- ! Ambient and Process temperature range,
- max. Surface Temperature and Temperature Class

### ATEX:

**Flameproof and Dust Ignition Proof** with intrinsically safe output to probe (Typecode Pos.2 W,T)

Ambient temperature range	Process temperature range	Max. Surface temperature (EPL Da)	Max. Surface temperature (EPL Db)	Temperature class (EPL Ga)
-40 to +70°C (-40 to +158°F)	-40 to +80°C (-40 to +176°F) (1)	T <sub>200</sub> 130°C	T85°C	T6
-40 to +85°C (-40 to +185°F)	-40 to +100°C (-40 to +212°F) (1) (2)	T <sub>200</sub> 130°C	T130°C	T5
-40 to +85°C (-40 to +185°F)	-40 to +135°C (-40 to +275°F) (1) (2)	T <sub>200</sub> 165°C	T130°C	T4
-40 to +85°C (-40 to +185°F)	-40 to +200°C (-40 to +392°F) (1) (2)	T <sub>200</sub> 230°C	T130°C	T3

(1) With option FFKM O-ring seal: Lower process temperature limited to -20 °C (-4°F)

(2) Only applicable for versions with thermal isolator

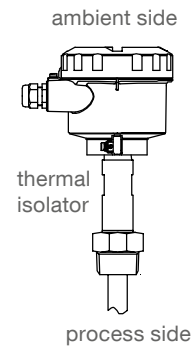

### INMETRO:

**Flameproof** with intrinsically safe output to probe

Application in Zone 0 (cat 1G)

Ambient temperature range	Process temperature range
-20 to +60°C (-4 to +140°F)	-20 to +60°C (-4 to +140°F)

Application in Zone 1 (cat 2G):

Ambient temperature range	Process temperature range	Temperature class
-40 to +70°C (-40 to +158°F)	-40 to +80°C (-40 to +176°F)	T6
-40 to +85°C (-40 to +185°F)	-40 to +100°C (-40 to +212°F) (1)	T5
-40 to +85°C (-40 to +185°F)	-40 to +135°C (-40 to +275°F) (1)	T4
-40 to +85°C (-40 to +185°F)	-40 to +200°C (-40 to +392°F) (1)	T3

(1) Only applicable for versions with thermal isolator

### Dust ignition proof

The maximum surface temperature of T 100 °C is based on a maximum ambient temperature of +85 °C.

### FM / CSA:

**Explosion proof / Dust ignition proof**

Ambient temperature range	Temperature class
-40 to +85°C (-40 to +185°F)	T4

Process temperature is not considered for definition of Temperature class.

## Probe modifications

---

### Shortening the rope (rope version)

Continuous level measuring system

#### NC 8000

#### CAUTION:

PFA insulated rope cannot be shortened.

Technical information / Instruction manual

### Methods

1. An angle grinder (preferably with a disc suitable for stainless steel)  
or
2. Wire cutters (suitable for piano rope Ø 6 to 9 mm).

### Procedure

1. Loosen the three set screws and pull weight from the rope.
2. Grind/cut the rope to the required length, and then remove rough edges from the rope.
3. Ensure that rope strands are properly seated in the lay of the rope (i.e. no wire strands sticking outside the normal rope profile). Make sure ALL strands are properly seated before continuing the assembly.
4. Push the weight onto the rope while simultaneously rotating it counter-clockwise around the rope. Make sure that no rope strands are pushed out of their position in the rope and that the rope is fully inserted.
5. Re-fasten the weight by tightening the three set screws.

