

# Analog Output with High Precision Pressure Transmitter

## MPM480



### Applications

- Mechanical manufacturing
- Hydraulic and pneumatic control technology
- Marine industry
- Petroleum and petrochemical industry
- Natural gas industry
- Municipal and environmental engineering

### Features

- Support reversed-polarity, overcurrent and overvoltage protection, conforming EMI protection requirements
- Intrinsic safety type, Ex ia IIC T6 Ga
- Explosion-proof type, Ex db IIC T6 Gb
- CE, RoHS and CCS approved

### Introduction

MPM480 pressure transmitter uses a stainless steel isolated piezoresistive OEM pressure sensor as the signal measuring element. It is available for a wide temperature compensation by using automatic computer test and laser trimming technology. It includes a signal processing circuit that is housed in a stainless steel housing and converts the milli-volt signal into a standard output signal. A rigid testing and screening is required in the whole manufacturing process of the product from the original components, semi-finished to the final finished product for stable and reliable performance.

### Specifications

Range	-1bar...0mbar ~ 100mbar...1000bar
Overpressure	2 times FS or 1100bar (minimum value is valid)
Pressure	gauge, absolute, sealed gauge
Accuracy	see Accuracy on page 2
Long-term Stability	±0.2%FS/year
Operation Temperature	-30°C ~ 80°C (B1, B3 type)
	-20°C ~ 70°C (B2 type, cable material: PE, PVC)
	-20°C ~ 80°C (B2 type, cable material: PUR)
	-10°C ~ 60°C (intrinsic safety type)
Storage Temperature	-20°C ~ 60°C (Exd type)
	-40°C ~ 120°C
Vibration	10g, 55Hz ~ 2000Hz
Shock	100g, 11ms
Protection Rating	IP65
Weight	≤375g

## Accuracy

Pressure Type	Range	Accuracy
Gauge (G)	0mbar ~ 100mbar < X < 200mbar	±1%FS
	200mbar ≤ X ≤ 1bar	±0.5%FS
	1bar ≤ X ≤ 35bar	±0.25%FS
		±0.5%FS
	-1bar ~ -350mbar < X ≤ 2bar	±1%FS
	-1bar ~ -350mbar < X < 2bar ~ 35bar	±0.5%FS
Absolute (A)	0mbar ~ 700mbar < X ≤ 1bar	±1%FS
	1bar < X < 10bar	±0.5%FS
	10bar < X < 1000bar	±0.25%FS
		±0.5%FS
Sealed gauge (S)	35bar < X < 1000bar	±0.25%FS
		±0.5%FS

Test standard: GB/T 17614.1-2015/IEC60770-1:2010;

Environment temperature: 20°C ±5°C ;

Relative humidity: 45%~75%

## Thermal Drift

Zero Thermal Drift	±0.03%FS/°C (≤ 1bar)
	±0.02%FS/°C (> 1bar)
Span Thermal Drift	±0.03%FS/°C (≤ 1bar)
	±0.02%FS/°C (> 1bar)

## Output Signals

Output Signal	Power Supply	Output Format	Load Resistance
4mA~20mA DC(E)	15V~28V DC (The intrinsic safe product is powered by a safety barrier)	2-wire	≤ (U-15)/0.02 (Ω)
0mA~10mA DC(Q)			
0mA~20mA DC(U)			
0V~5V DC(J)		3-wire	> 100 kΩ
1V~5V DC(F)			
0V~10V DC(V)			

Outline Dimensions

unit: mm

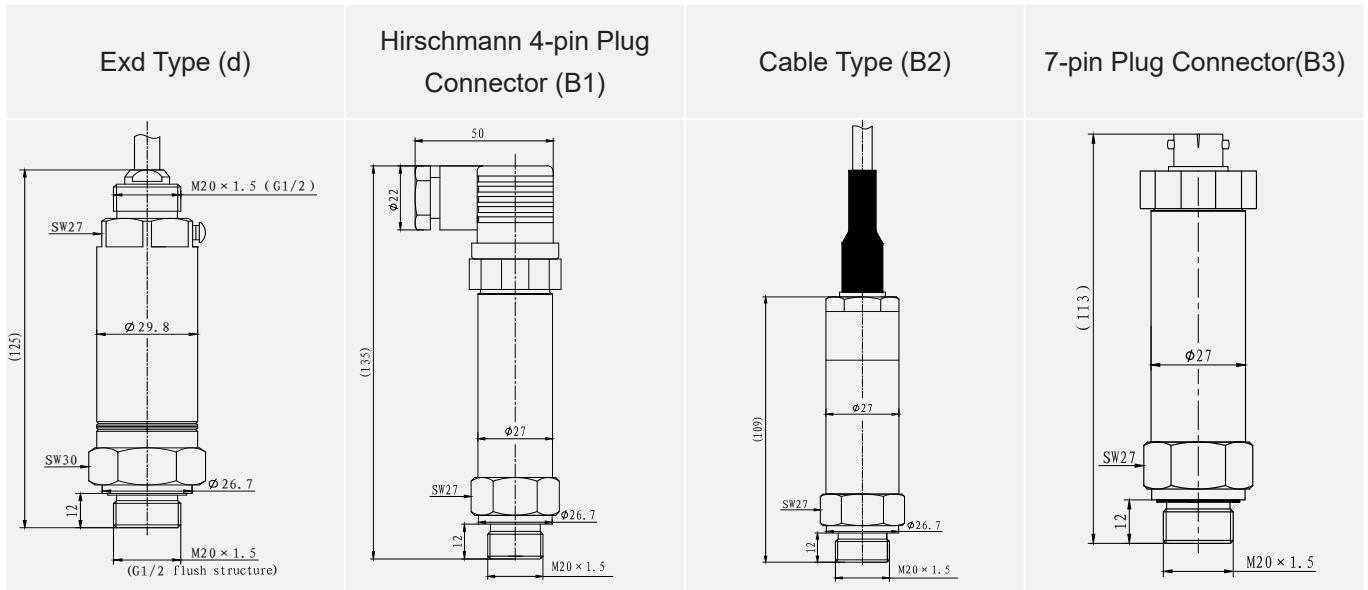

Electrical Connection

Definition	Hirschmann 4-pin Plug Connector (B1)		Cable (B2)		7-pin Plug Connector (B3)	
	current	voltage	current	voltage	current	voltage
	2-wire	3-wire	2-wire	3-wire	2-wire	3-wire
+V	1	1	red	red	1	1
+OUT	2	3	black	white	2	4
GND	null	2	null	black	null	2

Sensor Sealing

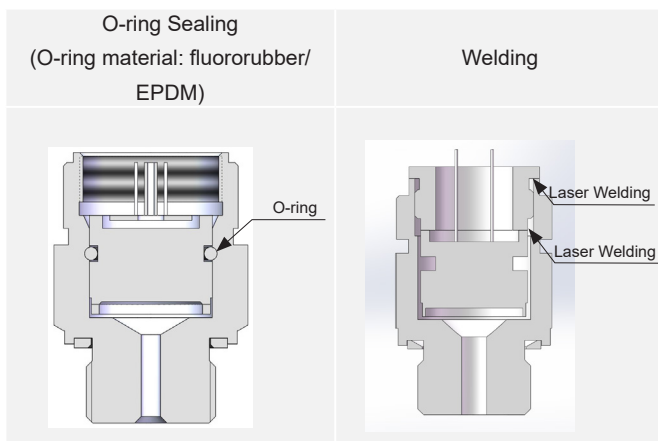

Material

Wetted Parts

Isolated Diaphragm: SS 316L/Tantalum  
 Pressure Port: SS 304/SS 316L/Hastelloy C

Non-wetted Parts

Housing: SS 304/SS 316L  
 Cable wire: PE/PUR/PVC

## Process Connection

### Process Connection Dimensions

unit:mm

M20×1.5 Male,End Face Seal (C1)

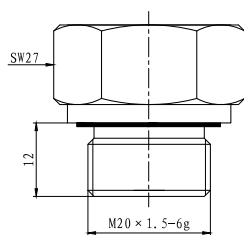

NPT1/4 Male (C6)

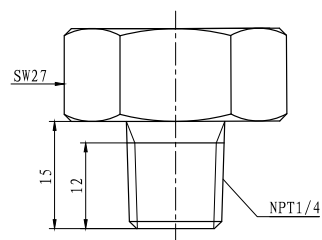

G1/4 Male, End Face Seal (C2)

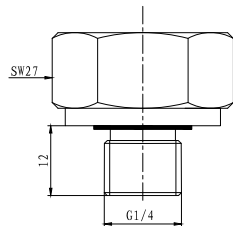

M20×1.5 or G1/2 Flush Diaphragm (PC1/PC3)

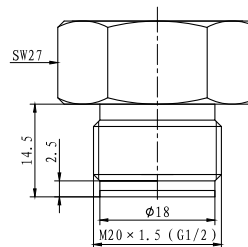

G1/2 Male, End Face Seal (C3)

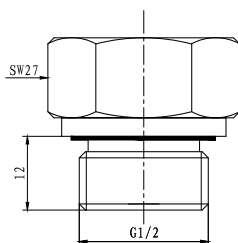

DN25 Clamp Connection (PD1)

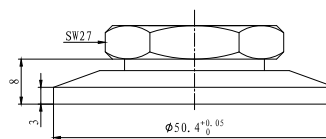

M20×1.5 Male,Waterline Seal (C5)

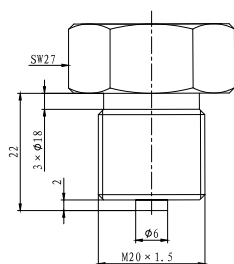

DN25 Clamp Connection with Heat Sink (PD1s)

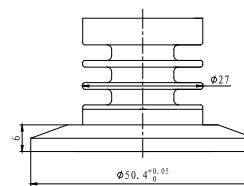

## Ordering Guide

MPM480	Pressure Transmitter									
	Range	Measurement Range: -1bar...0mbar ~ 100mbar...1000bar								
	[0 ~ X]mbarL or barL	X: actual measured range, L means cable length when electrical connection is B2								
	Code	Output Signal								
	E	4mA~20mA DC								
	Q	0mA~10mA DC								
	U	0mA~20mA DC								
	J	0V~5V DC								
	F	1V~5V DC								
	V	0V~10V DC								
	Code	Material								
		Isolated Diaphragm			Pressure Port			Housing		
	22	SS 316L			SS 304			SS 304		
	24	SS 316L			SS 316L			SS 316L		
	25	Tantalum			SS 304			SS 304		
	35	Tantalum			Hastelloy C			SS 304		
	Code	Electrical Connection								
	B1	4-pin plug connector								
	B2	cable connection								
	B3	7-pin plug connector								
	Code	Process Connection								
	C1	M20×1.5 male, end face seal								
	C2	G1/4 male, end face seal								
	C3	G1/2 male, end face seal								
	C5	M20×1.5 male, waterline seal								
	C6	NPT1/4 male								
	PC1	M20×1.5 flush structure						0mbar ~ 200mbar...350bar		
	PC3	G1/2 flush structure						0mbar ~ 200mbar...350bar		
	PD1	DN25 clamp						0mbar ~ 350mbar...350bar		
	PD1s	DN25 clamp with heat sink						0mbar ~ 350mbar...350bar		
	Code	Accessory								
	null	no accessory								
	M6	4 digits LED digital indicator (only for 4mA ~ 20mA DC output non-explosion proof or non-ship-use products with B1 electrical connection)								
	M7	4 digits LCD digital indicator (only for 4mA ~ 20mA DC output non-explosion proof or non-ship-use products with B1 electrical connection)								
	Code	Certification Requirement <sup>®</sup>								
	null	no certification requirement								
	i	intrinsic safe Ex ia IIC T6 Ga								
	T	ship-use								
	d	Ex db IIC T6 Gb								
	Code	Pressure Type								
	G	gauge								
	A	absolute								
	S	sealed gauge								
MPM480	[0 ~ 16]bar	E	22	B1	C2	M6	i	G	Complete Type Specification	

## Ordering Notes

1. " ① " refers to certification requirements. For the intrinsically safety type, current output is available only. The product can be intrinsically safe and suitable for ship-use simultaneously or can be intrinsically safe and flameproof simultaneously.
2. " ② ", for B1 and B3 electrical connection, please specify us in the order if cable is needed.
3. The application temperature range of fluororubber O-ring sealing is  $-20^{\circ}\text{C} \sim 250^{\circ}\text{C}$  , when application temperature  $< -20^{\circ}\text{C}$  , EPDM O-ring is needed.
4. The cable length is 1.5m by default, cable material is available for 3 types: PE cable is provided as default; if other material is needed, please specify in the order.
5. When ordering the transmitter with M6 or M7 indicator, power supply should  $\geq 20\text{V DC}$ .
6. Environmental temperature should be  $-20^{\circ}\text{C} \sim 70^{\circ}\text{C}$  when ordering the transmitter with M6 indicator, environmental temperature should be  $-10^{\circ}\text{C} \sim 60^{\circ}\text{C}$  when ordering the transmitter with M7 indicator, indicator setting can refer to our indicator lectotype, which can be found on our company's website.
7. If metrology verification certificate is needed or there are other requirements, please contact us and specify it in the order.
8. There are three types of upper thread of flameproof products(M20\*1.5, G1/2, NPT1/2), M20\*1.5 thread will be provided as default.