



RusAutomation

Operating manual

Microwave Barrier

Transmitting unit: LC510M-S

Receiving unit: LC510M-E



Operating manual for LC510M

Copyright © Müttec Instruments GmbH 2017 All rights reserved

This document is copyright protected. It supports the user in making reliable and efficient use of the unit. Transmission and duplication of this document as well as utilization and disclosure of its content are prohibited unless expressly permitted. Any breach or infringement shall result in liability for damages. The software described in this document is licensed and may only be used and copied in accordance with the terms of the licence.
All rights reserved.

Disclaimer

We have checked the content of the printed document for compliance with the described hardware and software. Nevertheless, deviations cannot be excluded and consequently we cannot assume any guarantee for complete accordance. The data in this printed document are checked regularly. Corrections and additions are made in the following version in each case. We would be grateful for any suggestions for improvement.

Subject to technical modifications

Contents

	Classification of safety information.....	4
	General information	5
	Introduction.....	6
1	General information for installation and operation	7
2	Installation instructions	8
3	Electrical connection	11
4	Settings (general)	12
	4.1 Setting transmitter	12
	4.2 Setting receiver	13
	4.2.1 Reset settings	14
	4.2.2 Operation Mode	14
	4.2.3 Hysteresis - Setting Hysteresis	15
	4.2.4 Filter - Setting Filter	15
	4.2.5 Address - Setting Address	16
	4.2.6 Represent error and mal functions	16
	4.2.7 MAX/MIN selection – switching behavior setting	17
	4.2.8 Miscellaneous.....	17
5	Operating conditions	18
	5.1 Commissioning	18
	5.2 Operation	18
6	Electrical connection and Extremes	19

Classification of the safety instructions

This manual contains instructions that you have to observe for your personal safety as well as to avoid material damage. These instructions are highlighted using a triangular warning sign and shown as follows, depending on the degree of risk.



HAZARD

means that death or severe physical injury will occur if the appropriate precautionary measures are not taken.



WARNING

means that death or severe physical injury may occur if the appropriate precautionary measures are not taken.



CAUTION

with a triangular warning sign means that minor physical injury may occur if the appropriate precautionary measures are not taken.



ATTENTION

means that an undesired result or state may ensue if the corresponding instruction is not followed.



NOTE

denotes important information about the product, handling of the product or the respective part of the documentation, is aimed at drawing special attention to the latter and should be complied with.

In addition to the instructions in this manual, the generally applicable safety and accident prevention regulations must be observed.

If the information contained in this document should not be sufficient in any specific case, you can obtain more detailed information from our telephone service.

Please read this manual carefully prior to installation and commissioning.

CE mark

This product meets the specifications according to the EMC Directive 2004/108/EG and the Low Voltage Directive 2006/95/EG.

General instructions

This device left the plant in flawless condition in terms of its safety features. To preserve this condition and ensure safe operation of the device, the user has to observe the instructions and warning notes indicated in this operating manual.

NOTE

For the sake of clarity the manual does not contain complete detailed information on all product types and can therefore not take into account every conceivable case with respect to installation, operation and maintenance.

Should you wish further information or should special problems arise that are not treated in sufficient detail in the manual, you can obtain the necessary information by telephone.

Moreover, we point out that the content of the manual shall not constitute part of or amend a previous or existing contract, agreement or legal relationship. All obligations of Mütéc Instruments GmbH shall result from the respective contract of purchase, which also contains the complete and solely valid warranty terms. These contractual warranty terms shall neither be extended nor limited by the information contained in the manual.

The content reflects the technical state of the art regarding printing. It is subject to technical modifications in the course of further development.

WARNING

Devices with the type of protection designated as “intrinsic safety” lose their conformity certification as soon as they have been operated in circuits that do not meet the values specified in the test certificate. Flawless and safe operation of this device requires proper transport, proper storage, installation and assembly as well as careful operation and maintenance. The device may only be used for the purposes specified in this operating manual.

DISCLAIMER

All modifications to the device fall within the responsibility of the user unless expressly specified otherwise in the operating manual.

Qualified PERSONNEL

are persons who are familiar with installation, assembly, repair and operation of the product and have the qualifications necessary for their work, such as:

- Training, instruction and/or authorization to operate and maintain equipment/systems in accordance with the standards of safety technology for electrical circuits, high pressures and corrosive as well as hazardous media.
- In the case of equipment with explosion protection: training, instruction and/or authorization to perform work on electrical circuits for potentially explosive equipment.
- Training or instruction in accordance with the standards of safety technology regarding care and use of appropriate safety equipment.

CAUTION

Potentially electrostatic components may be destroyed by voltage that is far below the limits of human perception. Such voltage occurs even when you touch a component or electrical connections of a component and are not electrostatically discharged. The damage that occurs to a component because of overvoltage usually cannot be detected immediately and does not become noticeable until after a longer operating period.



Introduction

Transmitter: **LC510M-S**

Receiver: **LC510M-E**



Fig. 1 Sensor housing made of stainless steel

The **LC510M-S/E** microwave level switch is used to detect limit levels. Typical applications include the detection of bulk solids in silos, storage bunkers and crushers, and the detection of mineral-rich liquids in pipes and containers. When the maximum level is reached, the path of the microwave signal is broken by the accumulation of material. The evaluation electronics in the receiver unit detect this and send out a message via the relay contact. To monitor a minimum level in a silo, the sequence is reversed, as the microwave signal path will only be activated after material has drained out. The relay contact is controlled according to the parameterisation.

Both probes are equipped with an active self-monitoring system. To alert the user when maintenance is necessary, there is a relay which is operated on a closed circuit principle. In its go-state, the closed relay contact offers the possibility of a series connection with additional contacts of other devices, thus allowing monitoring in the form of a centralised alarm. The microwave measurement system is housed in two sturdy flange casings and consists of a receiver unit and a transmitter unit, which must not be electrically connected with each other. Thanks to a measuring procedure which involves no contact with the product, zero-wear, maintenance-free, continuous operation is possible.



To guarantee functionality, the LevelCheck LC510M system can only be used with materials that the microwave does not penetrate or that do not absorb the microwave too much.

Performance characteristics

- Microwave measurement system with variable transmission frequency
- reliable measurement even when used with abrasive products
- simple installation and start-up
- transmitter and receiver with active self-monitoring
- Probe identification via addressing
- level and status display via LEDs and LED bar graph display
- Relay contact output on the receiver unit to detect level limits
- relay contact output for maintenance requirement alerts
- 24VDC supply with galvanic isolation

1. General construction and operation information

Safety instructions

If the device can no longer be operated safely, it must be put out of operation and secured to prevent unintentional operation. Reasons for this may include:

- Visible damage to the device
- loss of function or functional disturbances
- storage or operation at a temperature outside the permitted range
- moisture inside the device
- rough handling during transport

Before the device is put into operation again, a professional routine test must be carried out in accordance with DIN EN 61010, Part 1. This test should be performed by the manufacturer.

Intended use

The LC510M measuring system is used to detect level limits of microwave-impermeable material between the transmitter and the receiver. It is not designed to detect people or animals.

The measuring system is a high-frequency transmission system which emits directed electromagnetic waves. In order to limit the wavelength to within the prescribed frequency band, it must be ensured that the sensors are only operated within the permitted temperature range. If the sensor is mounted externally and is exposed to direct sunlight, it is especially important to be aware of measures to limit the sensor temperature.

The transmitter has a standby output, whilst the receiver has a standby output as well as a signal output. The signal output is provided as a changeover contact. The transmitter output and the receiver outputs are designed as control outputs. It is therefore not possible to use voltages and currents which are higher than those listed in the technical data.

2. Installation instructions

Both system components are built into a stainless steel housing. On this housing is a male thread which allows the sensor to be screwed into a socket and secured with a nut. Various mounting accessories are presented on the following page.

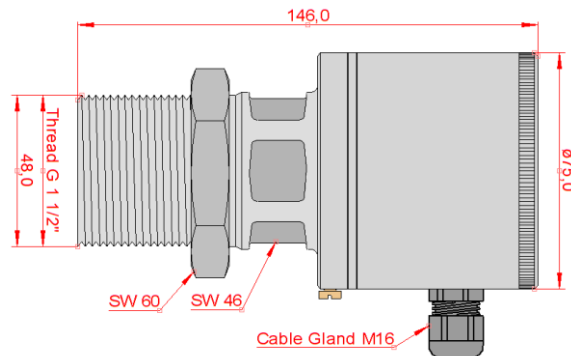

Fig. 2 Dimensions



Notes on installation

- The sensors are mounted on an optical axis, directly aligned with each other. Various mounting accessories are provided by the manufacturer to facilitate installation.
- The sensors should be mounted where the greatest material signal attenuation can be expected during the process.
- The sensors have a polarisation (horizontal or vertical). To decouple sensors, modify the polarisation between adjacent sensor pairs. In doing so, it is important to ensure that the sensors are turned in the same direction.
- To prevent water from entering the cable gland, these should be pointing downwards.
- If multiple sensor pairs are used, instead of rotating one sensor pair 90°, one pair of sensors should be rotated -45° and the other 45°.
- If several systems are operated in parallel (for example, for a level measurement), the sensors should be offset to each other by at least 30°.
- If the system is to be operated for level control in a silo or similar, the filling flow should not be located on the optical axis directly between the sensors, but as far away from this as possible.
- The distance between two sensor pairs should be greater than 0.25 times the diameter of the distance to be monitored. (Minimum diameter = 15 cm)
It is important here to bear in mind that if the distance between the transmitter and the receiver is very low, this could lead to disruptions between the pairs of sensors due to reflections. An installation offset by over 45° is therefore advised.
- The sensors should be mounted so that no material can be deposited in front of the sensor. In addition, the sensor should be mounted so that abrasive materials cannot damage the sensor. It is recommended that the sensor is mounted flush with the interior wall.
- After mounting, the sensor should be secured with the lock nut.

Mounting options and fixtures

Assembly example 1:

The LC510 measuring system is to be installed in a steel silo. A variety of weld-on sockets are supplied for installation in steel containers.

Socket Type 1: length: 22,5mm; material: steel

Socket Type 2: length: 22,5mm; material: stainless steel V4A

Socket Type 3: length: 48,0mm; material: stainless steel V4A

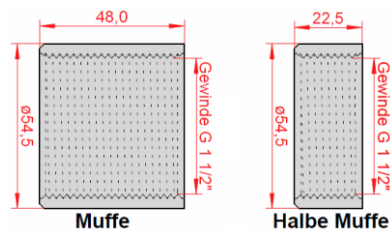

Fig. 3 Dimensions socket



The hole in the silo should be large enough that the sensor can be screwed in until it is flush with the interior wall.

Assembly example 2:

The LC510 measuring system is to be installed in a plastic silo. A flange mounted with screws is supplied for this type of installation.

Socket Type 4: socket on a 99,5mm * 99.5 mm mounting plate; material: V2A stainless steel

Dimensions:

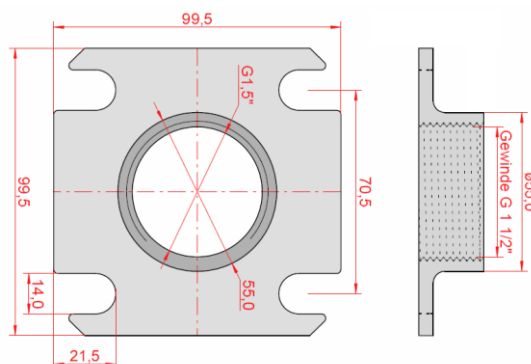

Fig. 4 Dimensions socket on mounting plate



If the mounting plate is mounted from the exterior so that the silo wall remains between the sensors, the wall of the silo must be made of a microwave-permeable material.

If the silo wall is not made of a microwave-permeable material, a hole is required for the sensor. The diameter of the hole should be large enough that the sensor can be screwed in until it is flush with the interior wall of the silo.

Application in a storage silo



General: The fill level inside the silo is to be controlled. For this purpose, two LC510M microwave level switches are used.

Mounting:

- ✓ The sensors (transmitter and receiver) are aligned directly with each other.
- ✓ The sensors are flush with the interior wall and are secured with the nut to prevent twisting.
- ✓ The housings of sensor pair 1 and sensor pair 2 are turned by 180°. This means they are decoupled as much as possible from each other.
- ✓ The distance between the sensor pairs is greater than 0.25 times the diameter of the distance to be monitored.

Function: Sensor pair 1 (Transmitter 1 & Receiver 1): Application Max.-Control
 Sensor pair 2 (Transmitter 2 & Receiver 2): Application min. control

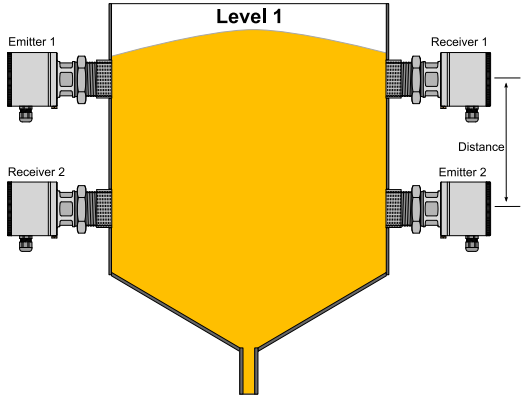
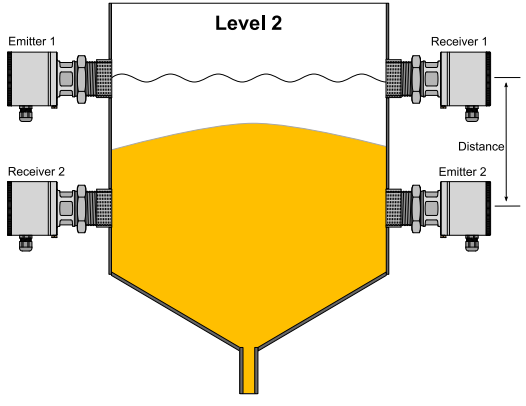
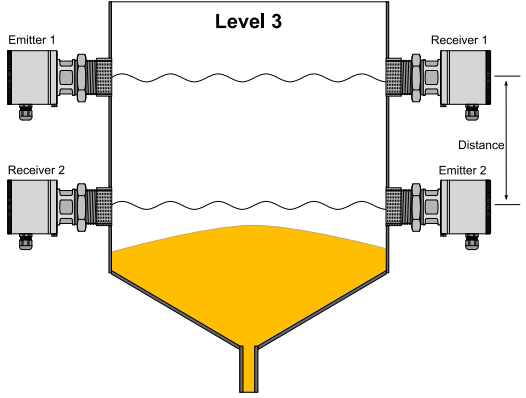
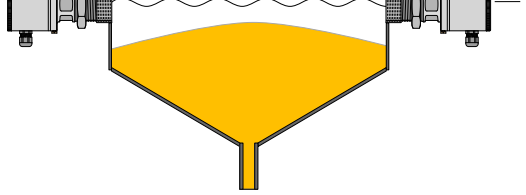
Statuses:

	<p>The silo is filled to the maximum level</p>	<p>Sensor pair 1 (max. control): Output opened</p>
	<p>Filling is stopped</p>	<p>Sensor pair 2 (min. control): Output closed</p>
	<p>The level in the silo is at the middle section</p>	<p>Sensor pair 1 (max. control): Output closed</p>
	<p>Filling is continued, if active</p>	<p>Sensor pair 2 (min. control): Output closed</p>
	<p>The level in the silo comes below the minimum</p>	<p>Sensor pair 1 (max. control): Output closed</p>
	<p>Filling is commenced</p>	<p>Sensor pair 2 (min. control): Output opened</p>

3. Electrical connection

The LC510M system consists of two units. After unscrewing the cover plate, the following connection terminals can be seen.

Sender:

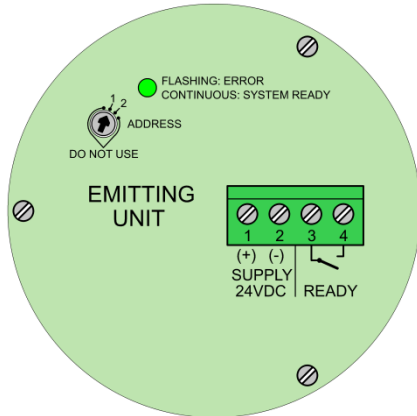

Clamp	Occupancy
1	Supply voltage + UB
2	Supply voltage – UB
3	Output ready (COM)
4	Output ready (NO)

Fig. 5 Wiring transmitter

Receiver:

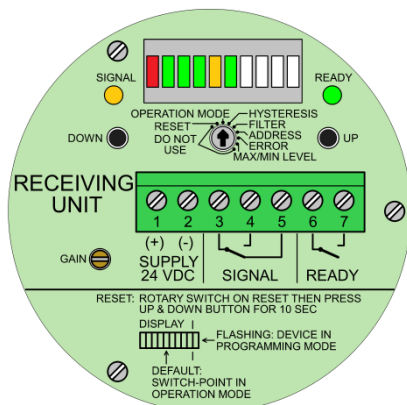

Clamp	Occupancy
1	Supply voltage + UB
2	Supply voltage – UB
3	Output signal (COM)
4	Output signal (NO)
5	Output signal (NC)
6	Output ready (COM)
7	Output ready (NO)

Fig. 6 Wiring receiver



Disregarding the technical connection conditions can lead to malfunctions, defects or the destruction of the device.

It is recommended that the supply voltages are protected on the energy side in the supply channel.

Outputs should be used in such a way that the equipment remains in a secure state when the device is idle or if there is a defect in the wiring.

If the receiver is ready for use, the Ready LED is lit up continuously and the Ready contact is closed. Only in this state is there a defined status on the signal contact.

The housing of all sensors must be earthed according to the instructions.

As a connection cable, it is recommended to use a shielded cable with a large enough cross section with an appropriate insulation class.

4 Settings (general)

The settings can be adjusted on the transmitter via a rotary multi-step switch, and on the receiver via a rotary multi-step switch, two buttons and a potentiometer. Removing the metal cover makes all controls and display elements accessible. In order to prevent damage to the device, removing the interior coverings is not recommended. Unauthorised interference with the device will void the user's authority to operate the equipment, as well as any warranty.

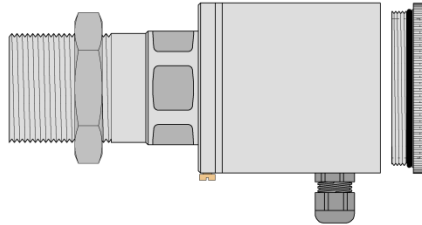

Fig. 7 Housing with open cover



If the transmitter does not function properly, the corresponding receiver may not function properly either. It is therefore recommended to cascade the Ready contacts. Here, the transmitter has a higher priority than the receiver and should therefore be positioned first.

4.1 Transmitter settings

The transmitter has a rotary switch to set the address to be used and an LED to display the status.

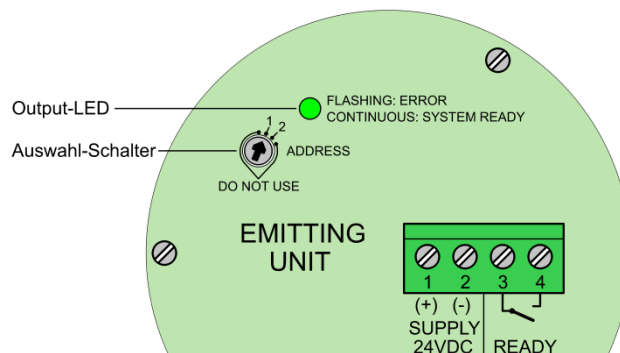

Fig. 8 Controls and display elements of the transmitter

Power-LED:

If the LED is continuously lit up, this indicates that the system test has not detected any errors and the Ready relay contact is closed. The device has an internal error identifier. If the LED flashes, the selection should be checked. If this is set correctly, this means there is an internal error and the Ready relay contact remains open.

Selection switch:

The rotary switch is used to select the setting.

Address 1: The transmitter transmits the identification of address 1.

Address 2: The transmitter transmits the identification of address 2.

Miscellaneous: not used

4.2 Receiver settings

The receiver has a rotary selection switch, two buttons, a level regulator, a bar graph, two LEDs and two relay outputs.

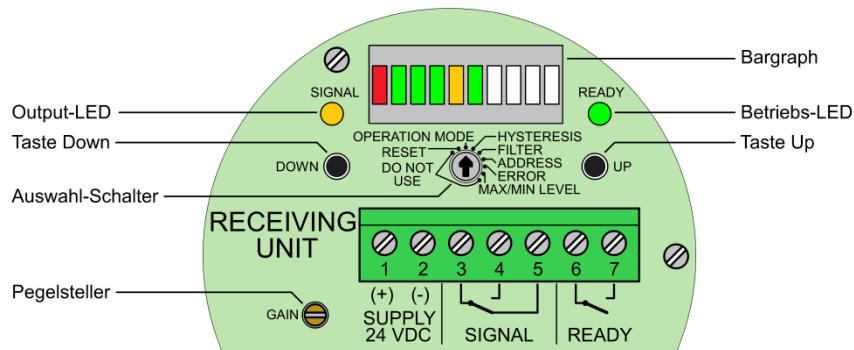

Fig. 9 Controls and display elements of the receiver

- Bargraph:** The bar graph is used to display the settings and/or the field strength.
- Output-LED:** This LED displays the status of the relay signal.
- Operation-LED:** The device has an internal error identifier. The status of the device is displayed via this LED.
- Selection switch:** The rotary switch is used to select the various settings.
- | | |
|-----------------|-----------------------------|
| Reset: | Reset menu settings |
| Operation Mode: | Normal operation option |
| Hysteresis: | Hysteresis settings |
| Filter: | Filter settings |
| Address: | Address settings |
| Error: | Show detected errors |
| MAX/MIN Level: | Signal output type settings |
| Miscellaneous: | not used |
- Up & Down buttons:** These buttons are used to modify the settings selected via the rotary switch. Each setting is covered by the various selection modes.
- Level regulator:** In operation mode, the strength of the received signal is displayed in the bar graph. This level regulator is used to adjust the amplification.

The following section explains the receiver settings. For this, the rotary switch is required for selection and the buttons to modify the menu settings. The bar graph and the LEDs are used for display purposes.

4.2.1 Reset - reset settings

Preparation: Set the rotary switch to the RESET option.

Function: To identify that the device is in settings mode, the green LED on the right of the bar graph flashes. In addition, the READY LED continues flashing. The status of the RELAY LED is disregarded.

Procedure: To reset the device, simultaneously press both buttons on the device for 10 seconds. In the bar graph, starting with the orange LED, the rest of the LEDs appear one by one. Once the whole bar graph is blinking, the menu settings are returned to the manufacturer's original settings.



After resetting, all settings must be checked and adjusted. The reset process cannot be undone.

4.2.2 Operation Mode

Preparation: Set the rotary switch to the Operation Mode.

Function: This is the mode which is used for the operation of the microwave level switch.

In this operational mode, the current signal level is displayed in the bar graph. The READY LED indicates the operation mode. If this is flashing, this means that an error has occurred. This can be read out. For further information, see 4.2.6 Error – read out errors. If there are no errors, the LED is lit up continuously. The Output LED displays the status of the output and/or signal relays.

Reset: To adjust the signal level using the level regulator, it is important to first ensure that the transmitter and the receiver are both properly mounted and attached. There must be nothing between the transmitter and the receiver. Next, the level is adjusted using the level regulator, as shown in the following image. When adjusting the level, a standard value is used and can vary in some applications.



Display:

Fig. 10 Target Level

Control: If there is material between the transmitter and the receiver, as in the normal process, the signal level must be at least small enough for the output to definitely change the status. For this purpose, the amplification may be adjusted according to the application.

In operation: After calibration, there is no need to change any settings. The function of the system can be checked using the bar graph and the LEDs.



The switching threshold is located at the 5th segment. This is lit up orange.

4.2.3 Hysteresis - settings

Preparation: Set the rotary switch to the hysteresis option.

Function: To identify that the device is in settings mode, the green LED on the right of the bar graph flashes. In addition, the READY LED continues flashing. The status of the RELAY LED is disregarded. The current setting is displayed. The settings after resetting the device are shown here in the following picture.

Reset: The hysteresis can be changed using the Up and Down buttons. The switching threshold is positioned symmetrically, starting from the position of the orange LED in the bar graph.

Display: 

Fig. 11 Hysteresis



A hysteresis which is set too low can lead to a tendency towards switch flickering in the output.

A hysteresis which is set too high can mean that the change from an unobstructed to an obstructed path between the transmitter and the receiver is no longer correctly identified.

To assist correct adjustment, it is recommended to inspect the signal level change between unobstructed and obstructed paths in operation mode, and to carry out an adjustment of the hysteresis accordingly.

4.2.4 Filter - Reset

Preparation: Set the rotary switch to the filter option.

Function: To identify that the device is in settings mode, the green LED on the right of the bar graph flashes. In addition, the READY LED continues flashing. The status of the RELAY LED is disregarded. The current setting is displayed.

Reset: The filter time can be changed using the Up and Down buttons.

Display: 

Fig. 12 Filter time



The adjusted filter time is displayed on a logarithmic scale rather than linearly.

The selection of an optimal filter time is dependent upon the respective process and should be adapted to this.

Pressing the left button reduces the time. Too short a time can mean that small particles between the transmitter and the receiver cause a change in the output.

Pressing the right button increases the time. Too long a time can mean that the change of status is no longer displayed or is displayed too late.

4.2.5 Address - Reset

Preparation: Set the rotary switch to the address option.

Function: To identify that the device is in settings mode, the green LED on the right of the bar graph flashes. In addition, the READY LED continues flashing. The status of the RELAY LED is disregarded. The current setting is displayed.

Reset: The address can be changed using the Down button for address=1 and the Up button for address=2.

Display: 

Fig. 13 Address 1



Fig. 14 Address 2



For this to function properly, the addresses of the transmitter and the receiver must be set the same.

4.2.6 Error – show error or fault

Preparation: Set the rotary switch to the error option.

Function: To identify that the device is in settings mode, the green LED on the right of the bar graph flashes. In addition, the READY LED continues flashing. The status of the RELAY LED is disregarded. If there is no display on the bar graph in segments 1 to 9, this means there is a signal malfunction. This can be rectified in the same manner.

Reset: No adjustment is made. This mode is used to display the current error status.



If there is an error or a fault, the following is suggested in order to rectify this:

1. The mounting and earth connections of the sensors should be checked and, if necessary, repaired.
2. The address settings of the transmitter and the receiver should be compared and aligned with each other if necessary.
3. It is possible that the signal is experiencing overdrive or interference from another device. Therefore, the amplification should initially be checked and then, as a second step, any influence on the microwave level switch from another device with a microwave measuring system should be eliminated.

4.2.7 MAX/MIN Level – set switching behaviour

Preparation: Set the rotary switch to the MIN/MAX Level option.

Function: To identify that the device is in settings mode, the green LED on the right of the bar graph flashes. In addition, the READY LED continues flashing. The status of the RELAY LED is disregarded. The current setting is displayed.

Reset: The function of the output is changed using the Down button for minimum control and the Up button for maximum control.

Conditions:

State / Select	Bargraph indication	Level	Output-LED	Signal-Output	Power-LED	Ready-Output
min. Level						
max. Level						
fault or disorder	deleted	not relevant	undefined	undefined		
no voltage supply						

Fig. 15 State overview



If there is an error or a fault, the relay of the output will not necessarily de-energized, nor will the LED switch off.

If there is a compound error cycle in the equipment, the standby contact can be used to suspend standby. If there is no compound error cycle in the equipment, the standby contact can be used to suspend signal.

Note: The standby circuit has a one-second delay. Activation can therefore only occur at least one second after switching on.

4.2.8 Miscellaneous - The user should not make any changes to these options.



Any change to these options will change the function of the device.

If a change has been made, the device must be reset and then started up again. The LC510M system will then be ready for operation once again.

5. Operating Conditions

5.1 Commissioning

Before starting up the device, it must be ensured that the system is properly connected with regards to the technical details, and that all applicable standards are implemented. An electrical test is recommended before starting up.

In order to be able to start up the system, the beam path between the transmitter and the receiver must be unobstructed. The order of the parameters to be set is the same as the order set out in the notes in chapter 4. The respective recommendations are listed along with the respective parameters.



Only once the system has been parameterized and the function checked by exceeding and falling below the switching threshold under controlled conditions, can the system be operated independently.

5.2 Operation

Transmitter: During operation, the LED is lit continuously and the contact is closed.

Receiver: During operation the following is displayed on the receiver:

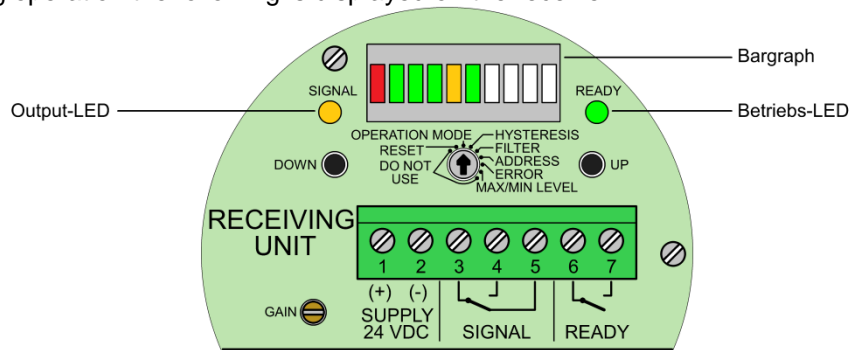

Fig. 16 Receiver in operation

Powers-LED: During operation, the LED is lit continuously and the contact is closed.

Output LED: The LED and the signal relay are controlled subject to the status of the path between the transmitter and the receiver. If the LED is lit up, the relay is energized and if it is not lit up, the relay is not energized.

Bargraph: The level of the received signal is displayed on the bar graph. If the received signal is below the switching threshold, the relay de-energizes after the filter duration and the Output LED goes out. As soon as the received signal exceeds the switching threshold, the relay energizes after the filter duration and the Output LED lights up.



If the described status does not occur, the system must be put out of operation immediately and the source of the error must be removed. A restart is then recommended.

7 Electrical Connections and Extremes

Housing material:	stainless steel
Sensor surface:	Teflon (optional ceramics for abrasive media)
Protection class:	IP65
Weight Transmitter / Receiver:	1,3kg
Storage temperature:	-20° to +60°C (non-condensing)
Operation temperature:	-20° to +60°C (non-condensing)
Process temperature:	-20° to +85°C
Process pressure:	0 to 2bar (optional 25 bar with ceramic sensor surface)
Power supply:	24VDC (18VDC - 30VDC)
Power consumption Transm. Receiver:	max. 80mA
Power:	less than 2 Watt
Frequency:	24,000Ghz to 24,250Ghz
Transmit Power Transmitter / Receiver:	10dBm
Measuring range	15cm to 25m
Hysteresis:	adjustable
Switching delay:	adjustable (50mSek to 50Sek)
Relay output:	NO or change over contact, potential free
Switching voltage:	35VAC or 45VDC
Switching current:	min. 10µA and max. 1A
Switching capacity:	35VA or 30W
Cable entry (2Stk):	M16
Connection:	Screw



If the maximum peak values are exceeded or fallen below, the warranty shall be invalidated.

Dimension:

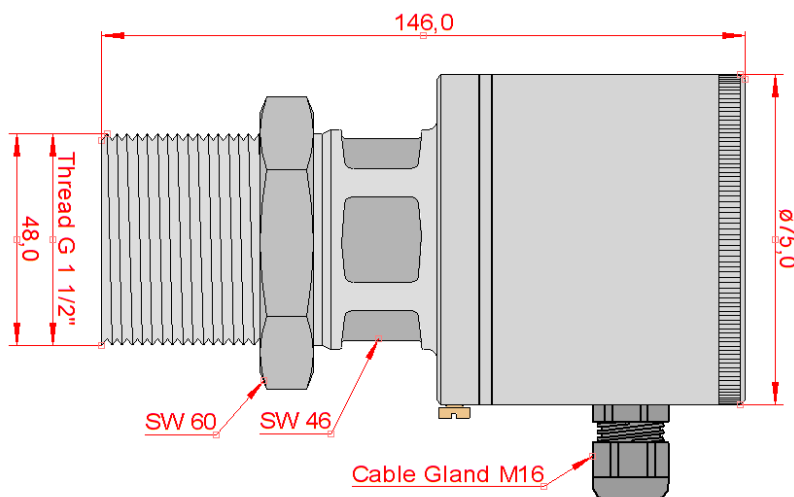

Fig. 17 Dimensions