

# LevelCheck 510M

Contactless level monitoring  
for bulk material



## Application

The microwave barrier LevelCheck 510M is designed for level monitoring of solids in silos, container, bunkers, shafts, etc.

Furthermore it can be used for: blockage-report, for counting piece goods or for positioning items. The devices are certified up to ATEX Zone 20 and optionally authorized for a process pressure up to 25 bar.

## Scope of use

Animal feed industry  
Building materials industry  
Production of ceramics  
Chemical industry  
Detergent industry  
Food industry  
Glass production  
Metal production

Pharmaceuticals  
Pigment production  
Power plants  
Production of rubber goods  
Recycling industry  
Synthetic materials  
Production of textiles  
Etc.

## Main Benefits

- ◆ Reliable microwave measuring principle
- ◆ Self-monitoring with additional relay
- ◆ For level monitoring
- ◆ Adjustable sensitivity, damping, hysteresis and filter function
- ◆ Adjustment via 2 key buttons and bargraph
- ◆ Easy installation by compact form
- ◆ Process connection with flange, thread, etc.

## Function

The measurement procedure of the LevelCheck 510M is based on the newest microwave technology. Therefore the sensor sends out a microwave signal. The signal is analyzed by the opposite receiver. Material, which has built up within this field, put a damp on the signal effect. This is converted into a switching process. The measurement is contactless.

Sensitivity, signal damping and hysteresis of the microwave barrier can be adjusted continuously and exactly by use of the bargraph. This enables a variable determination of the switching point resp. a switching process for different process applications.

The installation can be carried out within silos, bunkers, pipe systems or at similar transport facilities.

The assembly is simple, economical and easy possible also afterwards.

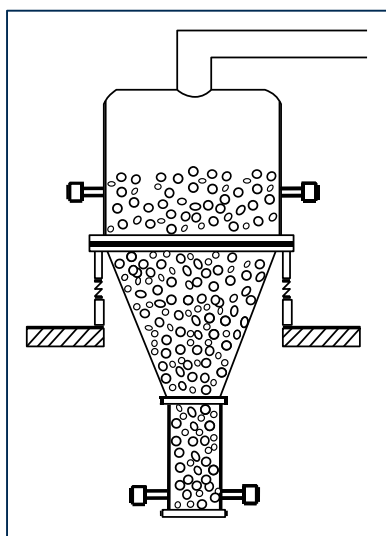

## Technical Data

Housing material	Stainless steel
Sensor surface	Teflon (optional ceramic)
Protection class	IP65
Ambient temperature	-20°C till +60°C
Process temperature	-20°C till +80°C
Process pressure	2 bar (optional 25 bar)
Power supply	18-30 VDC (typical 24 VDC)
Current consumption	Ca. 80 mA at 24 VDC
Transmitting power	10 dBm
Output (switching)	2x Relay output (change-over contact, pot.-free) optional transistor
Switching voltage	45 VDC / 35 VAC
Switching current	Min. 10 µA & max. 1 A
Switching power	30W / 35 VA
Electr. connection	Screw terminals (behind a screw cap with cable gland)
Adjustable parameters	Sensibility, filter time, hysteresis
Parameterization	via key buttons and switch
Indicators	LED green (power supply) LED orange (switch) Bargraph

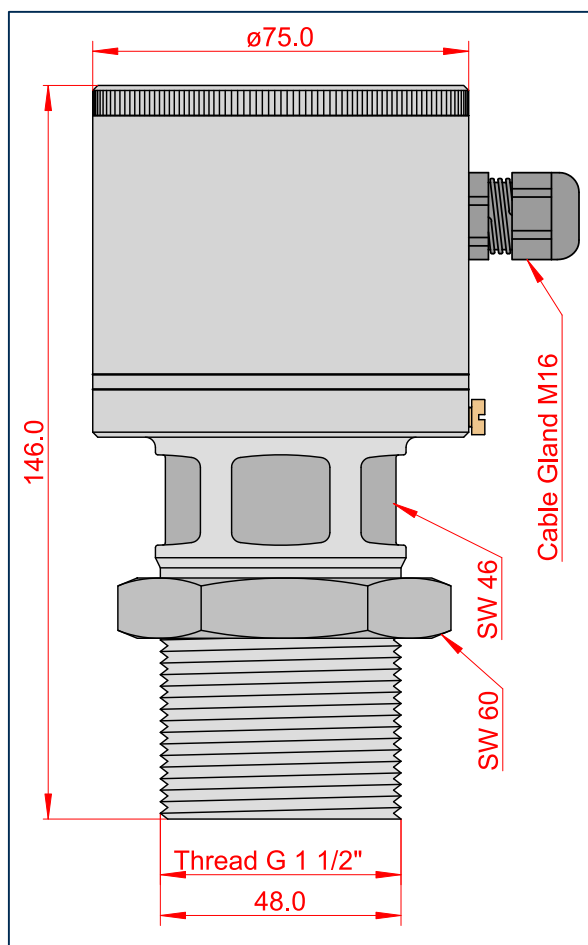

## ООО "РусАвтоматизация"