

JTR Guided Wave Radar Level Sensor Operation Instruction



Contents

1. Operation manual use	4
2. Product warranty	5
2.1 New product warranty	5
2.2 Repair warranty	5
2.3 Service Network	6
3. Product	7
3.1 Configuration	7
3.1.1 Model Label	7
3.1.2 Product Contents	7
3.2 Safety Inspection	7
4. Principles	8
4.1 Product Principles	8
4.2 Bottom Tracking Probe Technology.....	8
4.2.1 Bottom Tracking Probe Technology	8
4.2.2 Function Principle – Dual-Level Interface Measurement	9
5. Features	10
6. Specification	11
7. Installation	12
7.1 General Instructions	12
7.1.1 Lock Instrument	12
7.1.2 Moisture Proof Instructions	12
7.1.3 Operating Conditions	12
7.2 Installation Instruction	13
7.2.1 Installation Site	13
7.2.2 Feeding Tank Installation Precautions	15
7.2.3 Measuring range.....	15
8 Wiring Instruction	16
8.1 Preparations	16
8.1.1 Please Note the Following Safety Precautions before Use:.....	16
8.1.2 Connecting Cable	16
8.1.3 Power Supply	16
8.2 Wiring Instructions:	17
8.2.1 Connection Methods.....	17
8.2.2 Wiring Steps	17
8.3 Startup Instructions.....	18

9. Display Module Adjustment and Setting	19
9.1 Operation Steps:	19
9.1.1 Adjustment	20
9.2 Menus	20
9.2.1 Measurement Settings Menu	21
9.2.2 Display settings Menu	23
9.2.3 Diagnostics	25
9.2.4 Additional Settings Menu	26
9.2.5 Product Information Menu	27
9.3 Parameter table list	28
10. Warnings and Cautions	30
11. Troubleshooting	32
12. Communication Protocol Table	33

1. Operation manual use

Thank you for purchasing this FineTek product. This operation manual describes the product features, operating principle, operation and maintenance methods, as well as precautionary measures that should be taken during the installation, operation or maintenance of this product. This manual is designed to prevent dangerous situations that can result in damage to the product or injury to an installer or operator.

- Please read this operation manual completely and carefully before installing the product.
- Please contact FineTek if this operation manual does not answer your questions.
- The content of this operation manual may be updated from time to time. Updates are Maintained on the FineTek website www.fine-tek.com for your easy access.
- Do not disassemble or attempt to repair the product as this will void the product warranty. Please return the product to FineTek for repair and calibration if required.
- This manual may utilize warning symbols. An explanation of these symbols is as follows:



Danger→this symbol indicates an incorrect operation will result in major accidents and death.



Note→this symbol an incorrect operation will result in injury to personnel and some damage to the product.



Electric shock→this symbol warns of a possible electric shock hazard.



Fire→this symbol warns of a possible fire hazard.



Prohibited→this symbol indicates the action is prohibited.

2. Product warranty

2.1 New product warranty

- Each FineTek Guided Wave Radar Level Sensor is backed by 1-year limited warranty. Should you experience a problem with one of our products deemed by our factory to be a product failure covered by our warranty, for a period of 1-year from the delivery date we will repair the unit at our factory or provide you with a replacement unit or sub-assembly at our discretion. A return authorization number must be obtained from FineTek before returning any unit.
- If the Guided Wave Radar Level Sensor product failed to operate out-of-the-box, and this failure was not due to transportation, handling or incorrect Installation, then you can request a replacement unit within 7 days from the delivery date.
- When returning a product to the factory, return the entire device and do not disassemble the unit as previously mentioned. In addition, wherever possible please returning the device please ensure it is packed to avoid damage during transportation.
- When returning a product to the factory, return the entire device and do not disassemble the unit as previously mentioned. In addition, wherever possible please returning the device please ensure it is packed to avoid damage during transportation.

The product is not warranted in the following situations or conditions, therefore charges will result for repair of product:

- The product is beyond its warranty term.
- The defect or damage to the product is caused by the incorrect operation or by not following the installation and operation instructions contained within the operation manual.
- The product damage is a result of force majeure factors, including but not limited to natural disasters, floods, fires, earthquakes, lightning, severe weather conditions such as hurricanes, typhoons, tornadoes etc., human error such as use of improper voltage, high-humidity, water leakage, stains, corrosion, loss, improper storage etc. and other abnormal factors.
- The damage is caused by installation, addition, expansion, modification and repair of parts not authorized specifically or certified by FineTek.
- If the data label information on the product is incorrect or unclear so as to not be able to read or confirm the product serial number.

2.2 Repair warranty

Repaired product is warranted for 6 months from the delivery date. The warranty is limited to the part(s) replaced or repaired during the repair. If the repaired or replaced part is defective within this term the same part(s) will be repaired or replaced free of charge.

2.3 Service Network

Company	Address	Telephon	Fax
Taipei Headquarters (Taiwan)	No.16, Tzuchiang St., Tucheng Industrial Park, New Taipei City 23678	+886 2 2269 6789	+886 2 2268 6682
Taichung Sales office (Taiwan)		+886 4 2465 2820	+886 4 2463 9926
Kaohsiung Sales office (Taiwan)		+886 7 333 6968	+886 7 536 8758
Fine automation Co., Ltd. (China)	No. 451, Duhui Road, Zhuanqiao Township, Minhang District, Shanghai City 201109	+86 021 64907260	+86 021 6490 7276
Aplus FineTek Sensor Inc.	355 S. Lemon Ave, Suite D, Walnut, CA 91789	1 909 598 2488	1 909 598 3188
FineTek GmbH (Germany Branch)	Frankfurter Str. 62, OG D-65428 Ruesselsehim, Germany	+49 (0)6142 17608 0	+49 (0)142 17608 20
FineTek Pte Ltd. (Singapore Branch)	37 Kaki Bukit Place, Level 4 Singapore 416215Singapore 415979	+65 6452 6340	+65 6734 1878
FineTek Co., Ltd. (Indonesia Branch)	Ruko Golden 8 Blok H No.40 Gading Serpong, Tangerang, Indonesia	+62 (21) 2923 1688	+62 (21) 2923 1988
FineTek Co., Ltd. (Malaysia Branch)	8-05, Plaza Azalea, Persiaran Bandaraya, Seksyen 14, 40000 Shah Alam, Selangor, Malaysia	+603 5524 7168	+603 5524 7698

3. Product

3.1 Configuration

3.1.1 Model Label

The model label includes the product specification such as type, power supply, output mode, ambient temperature, process temperature and process pressure.

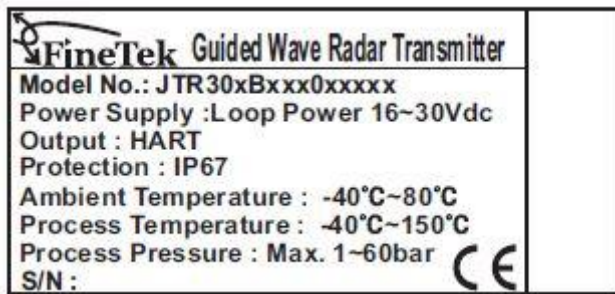

3.1.2 Product Contents

1. Sensor
2. Documents
 - Operation Manual
 - Inspection Certificate of Measurement Accuracy (Optional)

3.2 Safety Inspection

- a. Unpack and open the box
- b. Please check whether the external package is deformed or damaged. Please remember to take a picture for evidence in case you want to file for payment refund later.
- c. After unpacking, please check whether the content is deformed or damaged, or has any quality problem. Please remember to take a picture for evidence in case you want to file for payment refund later.
- d. After unpacking, please check whether the content is consistent with the ordering info, and whether the quantity is right.
- e. Please contact the company within 7 days for any of the above situations (with picture attached). Otherwise, we won't refund, change or repair the product.

4. Principles

4.1 Product Principles

The guided wave radar emits a high-frequency pulse wave to be transmitted along with the detection component (steel rope or connecting rod). When it comes in contact with the object to be measured, the pulse wave will be reflected and some of the energy will be reflected as well due to the different dielectric constant of air and the material. The time difference between the reflection wave and the emission wave can be used to calculate the distance between the surface of the measured object and the guided wave radar level sensor.

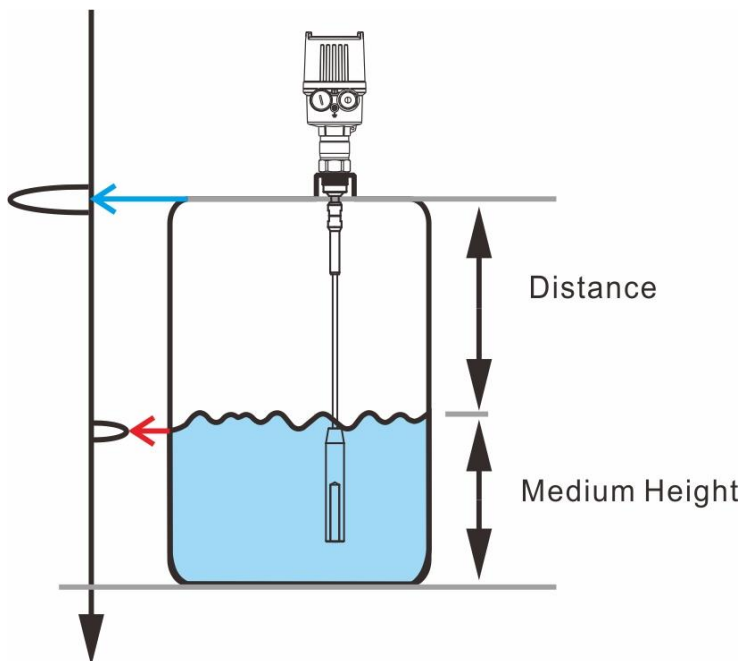

4.2 Bottom Tracking Probe Technology

4.2.1 Bottom Tracking Probe Technology

The product is equipped with a bottom tracking probe technology. This function is very useful in increasing the sensitivity when the dielectric constant of the measured object is low, such as the plastic particles, material fragments or that in the liquefaction container. When the dielectric constant is 3~10, the bottom tracking probe function will be enabled automatically as long as the echo signal is not detected. The measurement value is calculated based on the dielectric constant recorded the last time. In this case, the instrument accuracy depends on the stability of the dielectric constant.

If the dielectric constant of the media is lower than 3, the bottom tracking probe function will be enabled all the time. Under this circumstance, you must input the dielectric constant of the media, which is quite important for measurement.

4.2.2 Function Principle – Dual-Level Interface Measurement

The high-frequency micro wave pulse travels along the steel rope or the connecting rod. When it reaches the media surface, a part of the micro wave pulse will be reflected. Another part will penetrate the media in the upper layer (L1), and the second reflection will take place on the interface between the upper (L2) and lower (L1) interface layers. The two periods of pulse running will be calculated by the PCB inside the instrument, which also outputs two levels.

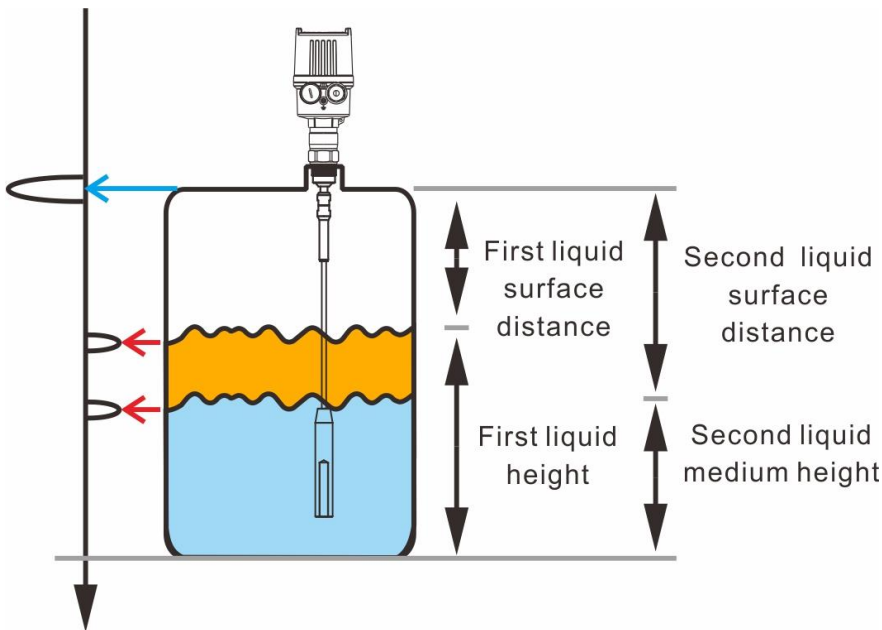

※ Measurement condition of dual-level interface:

Media on the upper layer (L2):

L2 must be non-conducting media. The dielectric constant of the media in L2 or the actual distance towards the interface is known. The dielectric constant of the media in L2 must be larger than 1.6. The media must be stable without change or mixture. Moreover, it must be uniform. The minimum thickness of the media in L2 should be larger than 50mm (1.97-inch), and L2 must be clearly separated from the lower layer (L1). In case of emulsion phase or chipping layer, the maximum thickness should be 50mm (1.97-inch). It should be without foam on the surface if possible, so it will get better measurement results.

Media on lower layer (L1):

The dielectric constant of L1 must be 10 larger than that of L2 at minimum, and the conducting media is recommended. For example, if the dielectric constant of L2 is 2, the dielectric constant of L1 should be 12 at least.

Gas layer (L3): It is the mixture of air or gas.

Output signal setting of dual-level interface measurement:

This instrument requires applying the setting in “level measurement”, which should be applied in dual-level interface measurement. You may select dual-analog output version and adjust the settings.

5. Features

- It meets the measurement requirements of different temperatures, pressures and media.
- Based on the contact measurement, it can overcome the effects from steam, foam and stirring.
- 2-wire loop power for simple wiring
- Local LCM display for convenient on-site adjustment.
- Unique algorithm and echo processing technology can be applied in various complicated conditions.
- Echo wave graphics display function, to show the signal waveform inside the tank, can be used for background noise processing.

6. Specification

Model	JTR302	JTR30A	JTR301	JTR305
Applicable Environment	Solid/Powder/Particle	Liquid/solid	Liquid	Low Dielectric Liquid
MeasuringScope	Rod type:6m Steel wire cable type:20m	Rod type:6m	Rod type:6m Steel wire cable type:20m	Coaxial type:6m
Connection	1"PF	1"(3A)	3/4"PF	
Min. Dielectric coefficient	2.0			1.6
Ambient Temperature	-40~80°C		-40~80°C	
Operating temperature	-40~150°C (Max.230°C)		-40~150°C(Max.230°C)	
Operating pressure	0~60 bar(25°C)		0~60 bar(25°C)	
Accuracy	±5 mm		±5 mm	
Analog output	4~20 mA		4~20 mA	
Power supply	16~30 Vdc Loop Power,16~30 Vdc 4-wire		16~30 Vdc Loop Power,16~30 Vdc 4-wire	
Digital communication	HART 7.3 for 2-Wire, Modbus for 4-Wire		HART 7.3 for 2-Wire, Modbus for 4-Wire	
Housing material	Aluminum alloy		Aluminum alloy	
Load Impedance	(VS-16)/0.022A Ohm for 2-wire;300 Ohm for 4-wire>16V		(VS-16)/0.022A Ohm for 2-wire; 300 Ohm for 4-wire>16V	
IP Protection rating	IP67			
Blind area	High dielectric coefficient ($\epsilon > 10$) : Upper blind area < 100mm · Lower blind area < 50mm Low dielectric coefficient ($\epsilon < 10$) : Upper blind area < 500mm · Lower blind area < 100mm			
Ex-PROOF (option)	NEPSI Ex ia IIC T2~T4 Ga IECEx Ex ia IIC T2~T6 Ga ATEX  II 1G Ex ia IIC T2~T6 Ga			

7. Installation

7.1 General Instructions

7.1.1 Lock Instrument

When locking the instrument and the tank, the suitable hex wrench should be used to fasten it.



Note! During the installation, please apply force on the hex screw to fasten it. Don't apply force on the instrument housing because it may damage the internal parts.

7.1.2 Moisture Proof Instructions

During the installation, you may take the following measures to protect the instrument from moisture:

- Use the appropriate cable (The standard cable for this instrument is 1/2"PF cable connector)
Fasten the cable connector
- Direct the cable connector downwards when installing, so as to prevent moisture
- When connecting with the cable, leave a small segment of cable hanging down in front of the fixing header.
- Prevent moisture from entering the housing along the cable.

Please pay special attention to moisture proofing when the product is applied in the following environments:

- Outdoor installation
- Installation in areas with estimated high moisture (such as cleaning process equipment)
- Installation in cooling or heating containers

7.1.3 Operating Conditions

When using the instrument, please check whether the specification of all parts meets the operating environment where it is exposed, including:

- Measuring sensor
- Connecting or fixing thread or flange
- Sealing material

Especially the following conditions in the specification:

- Operating pressure
- Operating temperature
- Properties of chemical media
- Abrasion and mechanical effects



Note! If the instrument is applied in the pressure tank or the low-pressure container, it must be sealed when fixing during the installation. Before usage, it must be checked as to whether the operating temperature of the sealing material meets the ambient temperature.

7.2 Installation Instruction

7.2.1 Installation Site

Pay attention to the following when installing JTR3 series products. When it is installed in a metal container, the distance between the container parts and the inner wall should be at least over 300mm. For non-metal containers, the distance to the inner wall should be at least over 500mm. During the operation, make sure the sensor doesn't get into contact with any device or tank wall. When using the sensor of a steel rope, it is recommended fixing the sensor bottom in the tank to reduce the vibration to the sensor. For the tanks with core shape at the lower part, it is recommended installing the product in the center of the container to measure the lowest point at the bottom.

※Please note the upper/lower blind area of the instrument. It can't measure the lowest point of the sensor.

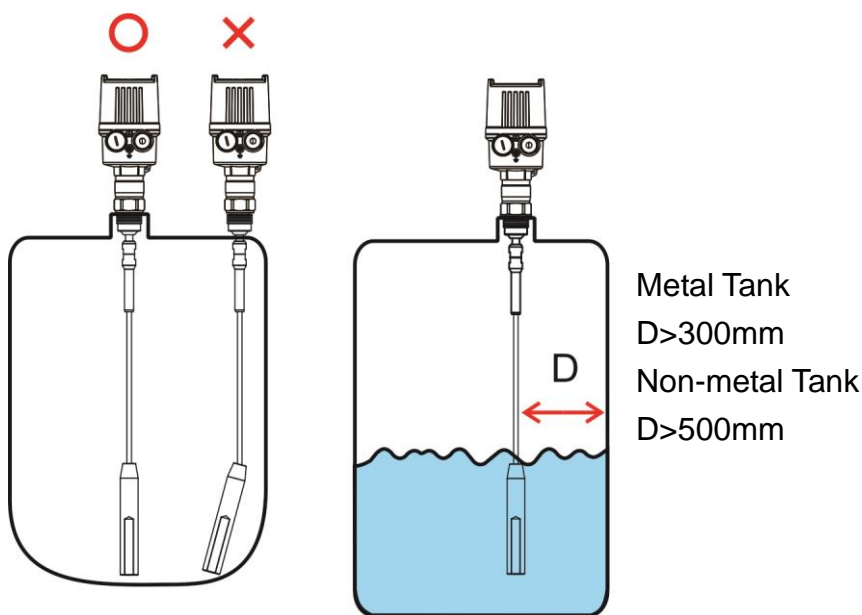

Note! When welding is required for the installation, please remove the electronic module of the sensor from the junction box before welding. It can prevent the damage on the electronic device due to the inductive coupling or other abnormalities.

Plastic container/glass container

The measuring principle of guided wave radar requires a metal plane at the process junction point. Therefore, when it is used in the plastic container, it requires an instrument with flange (since DN 50) or a metal plate ($\varnothing > 200$ mm/8 in) placed under the process connection.

Note, the metal plate should be connected with the process connection directly. When installing the measuring sensor of the connecting rod or steel rope in the plastic container without a metal wall, the measuring value will be affected by the strong electromagnetic field (The interference emission based on EN 61326: Class A). In this case, please use the co-axis measuring sensor.

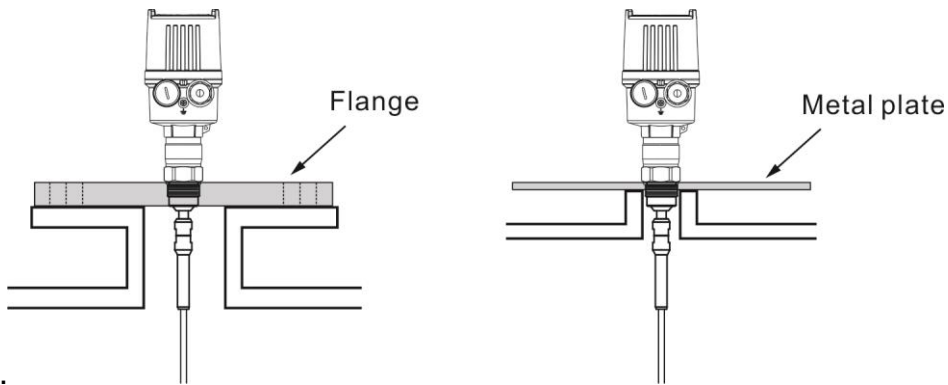

During the installation, don't use extension pipe on the container. Kindly install the sensor and the container cap flush with the ground.

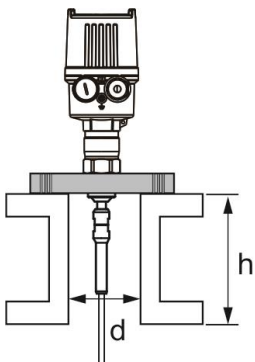

d	h
DN40~DN150	≤ 150
>DN150~DN1200	≤ 100

※ When welding the connector of the extension pipe, please make the edge of the extension pipe connector flush with container cap.

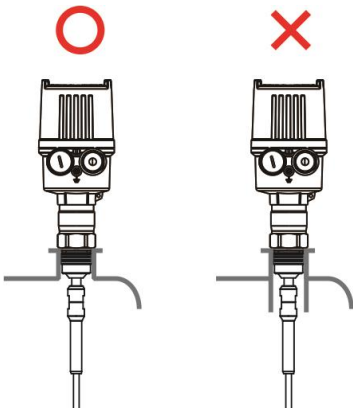

7.2.2 Feeding Tank Installation Precautions

Please don't install the instrument at the feeding port. The instrument must be in a position with stable media rather than a position with liquid flow. It can't provide accurate measurement when the liquid flows in.

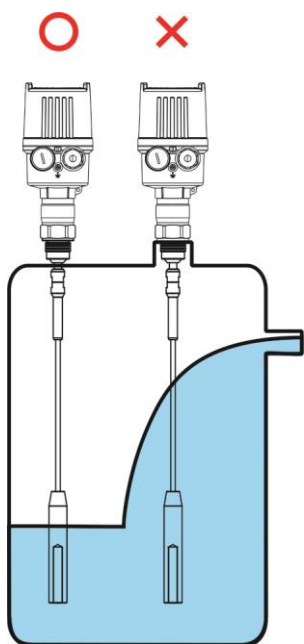

7.2.3 Measuring range

The measuring range is from the bottom of flange or head.

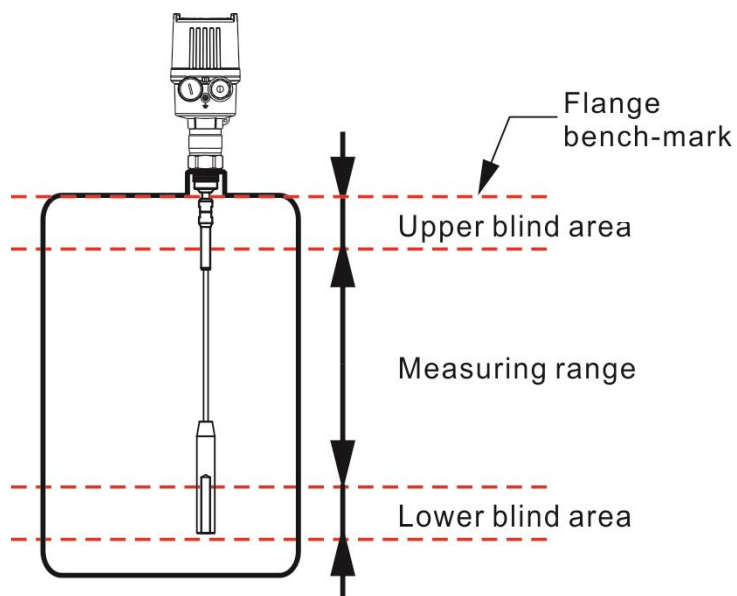

※ Note, the measuring range is from the reference to the bottom of the sensor, but not including the upper/lower blind areas. For the default measuring range of the instrument, it is set based on the media, "water".

8 Wiring Instruction

8.1 Preparations

8.1.1 Please Note the Following Safety Precautions before Use:

The instrument wiring is only permitted when it is powered OFF.

If overvoltage occurs to the wire, please install overvoltage protection device to protect the instrument.

8.1.2 Connecting Cable

The instrument can be connected with the general 2-core wire without the shielding layer available on the market.

If electromagnetic coupling phenomenon occurs to the installation and wiring environment, and the value exceeds the inspection value of EN61326-1 Standards applicable to the industrial field, the cable with shielding cable should be used. For the instrument with housing and cable screw thread connector, please use the cable with circular cross-section. Please check the external diameter of the cable applicable to the cable screw thread connector, so as to ensure the sealing on the cable screw thread connector (IP protection method). Please use the cable screw thread connector matching with the cable diameter.

Note!

When wiring, please follow the requirements of DIN EN 61140 VDE 0140-1(Protection against electric shock - Common aspects for installation and equipment), to guarantee the safety isolation between the power circuit and the grid circuit.

When the cable with shielding isolated mesh is used, it is recommended setting up the shielding isolated mesh on both sides of earth potential. In the sensor, the shielding isolated mesh must be directly connected with the internal grounding terminal. The external grounding terminal on the housing must be connected with the low impedance of the earth potential. For explosion-proof equipment, it should perform grounding based on the requirements on the license.

For the electroplating and KKS equipment (cathodic anticorrosion protection), the great potential difference should be considered. When the shielding isolated mesh is grounded on both sides, it may cause the current of the shielding isolated mesh to exceed the permitted scope.

8.1.3 Power Supply

The product is connected with a 2-core wire to supply power and send current signal
Working voltage (Vs):

With display adjustment module: 16~30VDC

Load impedance:(Vs-Vmin)/0.022A

For example: When supplying 24VDC for the instrument with display adjustment module:
(24-16)/0.022 = 363Ω

8.2 Wiring Instructions:

8.2.1 Connection Methods

When wiring, make the 2-core wire go through the enclosure, and make a connection based on the positive/negative power supply as marked on the nameplate. A flathead screwdriver may be used for connection.



8.2.2 Wiring Steps

Please follow the steps below:

1. Remove the cover on the housing.
2. Remove the display module by rotating it counterclockwise.
3. Loosen the fixing screw on the cable screw thread connector
4. Remove the jacket of about 10cm (4in) on the cable, and remove the insulation of 1cm (0.4in) at the core wire end.
5. Make the cable go through the cable connector, and insert it inside the housing.
6. Connect the wire to the terminal according to the wiring diagram
7. Pull it gently to check whether the wire is fixed firmly on the terminal
8. Connect the shielding with the terminal of the internal grounding wire, and connect the terminal of the external grounding wire with the electric potential compensation.
9. Fasten the fixing screw of the cable screw thread connector, and make sure the sealing ring is completely surrounding the cable
10. Re-assemble the display module.
11. Put on the housing cover to complete the electric connection

Wiring Diagram
JTR30XD series

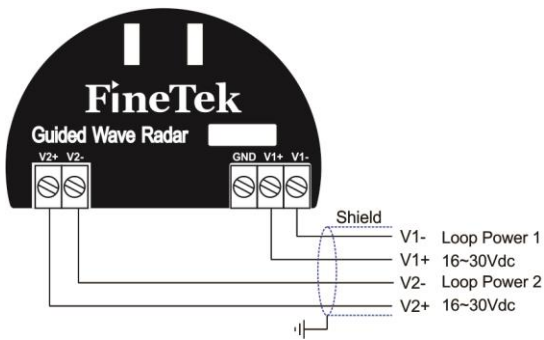

JTR30XB series

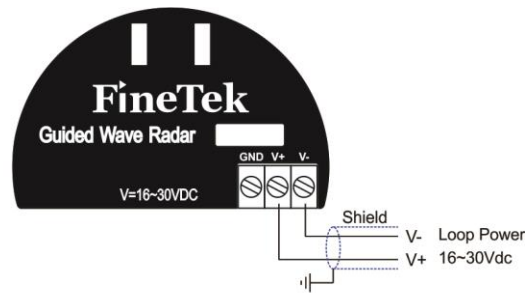

JTR30XH series

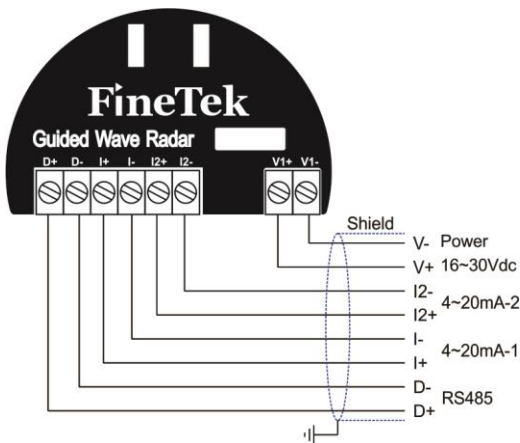

JTR30XE series

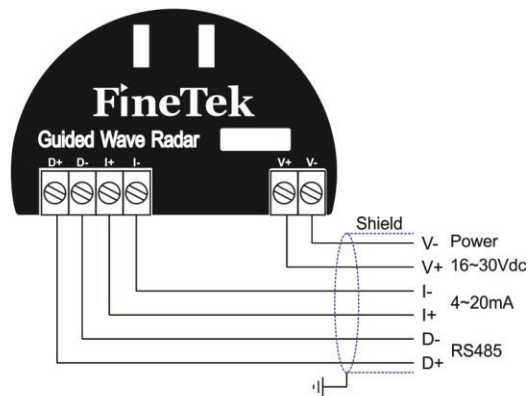

JTR30XF series

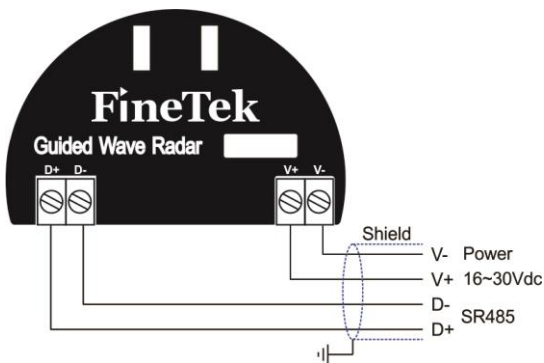

Note!

The product is of 2-wire loop power power supply. When it is applied for two analog outputs, the current for each circuit should be measured individually. Parallel connection of the two circuits will cause abnormal current output.

8.3 Startup Instructions

After the instrument is connected with the power supply and powered ON again, it will start system initialization and self-diagnosis for about 30 seconds:

- Internal inspection of the electronic parts.
- It will show the model type, hardware and software version on the display module.

9. Display Module Adjustment and Setting

9.1 Operation Steps:

1. Rotate the housing cover counterclockwise to remove it.
2. Adjust the display module on the electronic part at the required direction, rotate clockwise to fix it.
3. Fasten the housing cover. The disassembly should follow the reverse direction.

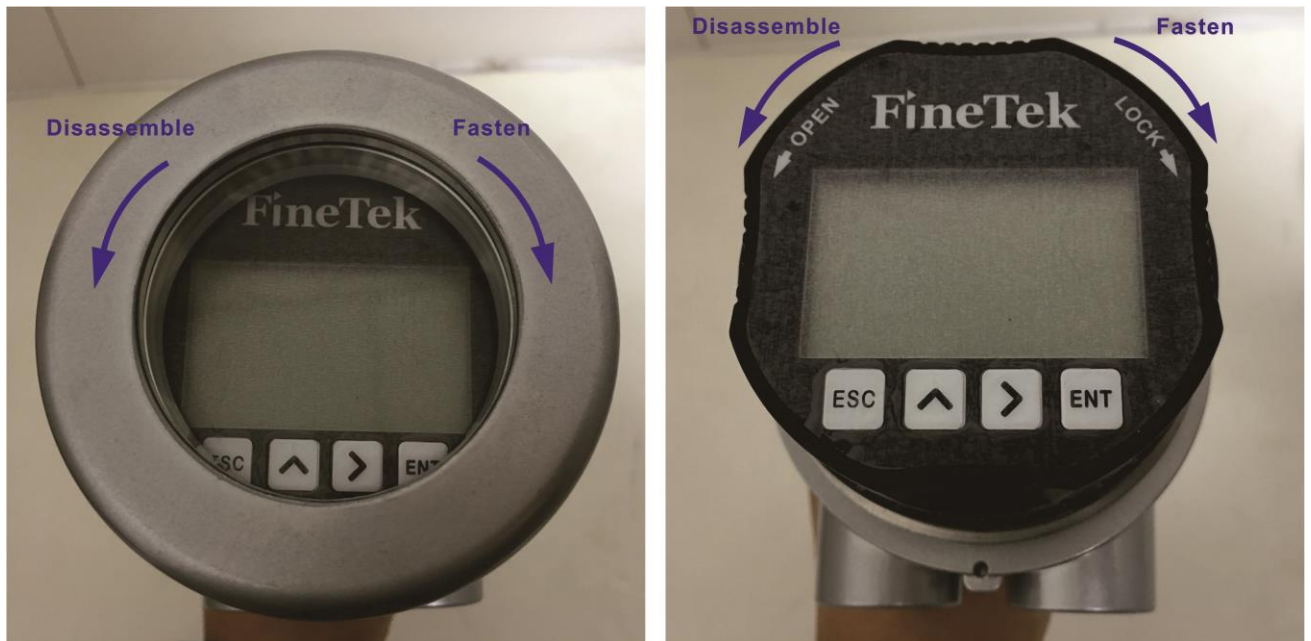

- [ENT] button : –Enter the menu–Confirm the selected content– Save the value
- [>]button : –Select item in the menu – Select the edit field
- [^]button : –Add setting parameter value
- [ESC]button : –Go back to the previous menu layer

9.1.1 Adjustment

The transmitter can be adjusted through the display module. LCM display can show the content of various menus.

The functions of the 4 buttons are as introduced above.

It will show the measurement value automatically if the buttons are not operated for 4 minutes.

JTR3 series guided wave radar will perform a short self-diagnosis after it is powered ON. During the startup procedure, the current output is 4.0mA. Moreover, the display module will show the information as below:

- Model type
- Software version (SoftWare-Ver)
- Hardware version (HardWare-Ver)

9.2 Menus

The LCM display can show two data values and a percentage. The data values can be modified as distance or material height according to demands, which can be set to probe length/current/percent.

When a single media is measured, the two data values are corresponding to the same measurement value. When it is applied in the liquid interface, the upper part shows the first interface measurement value, while the lower part shows the second interface measurement value.

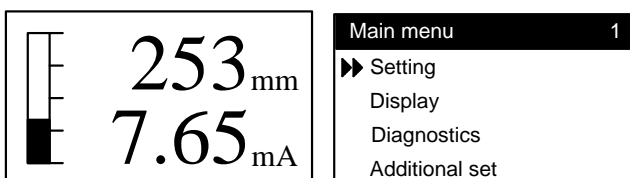

The main menu is divided into 5 parts, as introduced below:

Setting (1): It includes the parameter settings related to measurement, such as unit, probe length, and high/low level adjustment.

Display (2): It includes the language, display content of the measurement value, contrast.

Diagnostics (3): It includes information such as the measurement peak, echo curve, instrument status, etc.

Additional Set (4): It includes the communication mode, reset, dielectric constant, etc.

Information (5): It includes the hardware and software version, the production date, etc.

9.2.1 Measurement Settings Menu

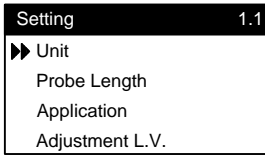

Measurement Settings (1) includes 6 parameters for setting, as introduced below:

Unit Type (1.1): It is to set the unit of measurement value shown on the LCM screen.

Probe Length (1.2): It is to set the length of sensing probe.

Application (1.3): It is to set the application model and dielectric constant of the media to be measured.

Adjustment L.V. (1.4): It is to set the upper/lower limit corresponding to 4-20mA and the percentage.

Filter Level (1.5): It is to set the output filter level.

Current Set (1.6): It is to set the current output direction (4~20mA/20~4mA).

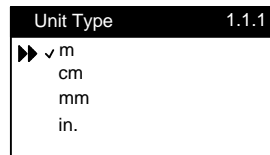
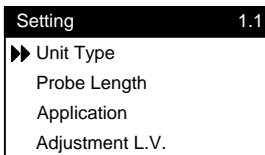

In the Unit (1.1) menu, user may adjust the unit of measurement value shown on the LCM display, with 5 available units, m/cm/mm/in/ft.

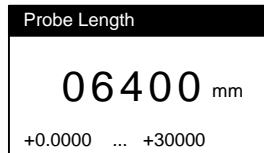
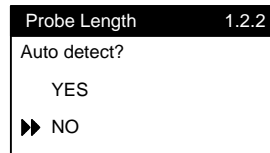
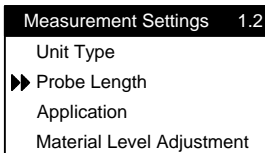

Probe Length (1.2) is applied in the bottom tracking probe mode, which can be filled after the probe is changed, or detected automatically by placing the instrument in an empty tank.

Note: The material height shown on the instrument is the probe length deducted with the distance from the material level to the flange reference plane.

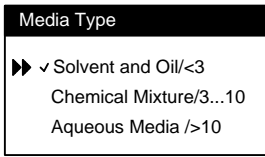
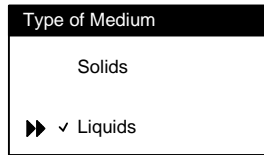
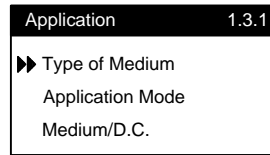
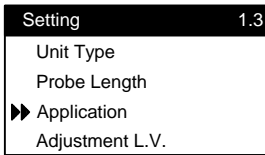

Application (1.3) menu provides settings based on application media and condition, including the following parameters:

Media Type(1.3.1): It is to set solid or liquid media based on the measured media.

Media/ Dielectric Constant (1.3.2): For solid media, it is to set the media as [Dust, Wood Chips/<1.5, Particles, Cement /1.5...3, Object, Powder />3]; For liquid media, it is to set the media as [Solvent and Oil /<3, Chemical Mixture /3...10, Aqueous Media />10]。

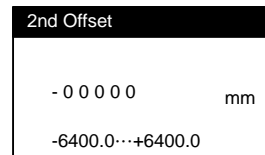
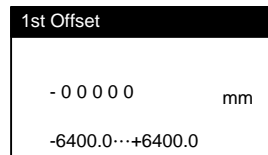
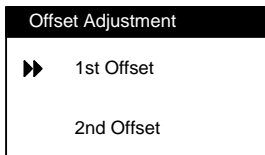
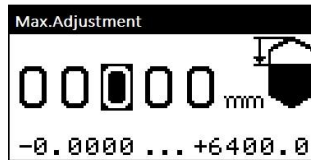
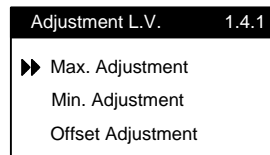
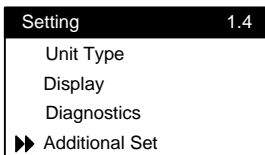

Material Level Adjustment (1.4) menu can be divided into High Level Adjustment (1.4.1) and Low Level Adjustment (1.4.2) used to set the upper/lower limit(0/100%) shown on the LCM display and upper/lower limit(4/20mA) of analog output.

Deviation Adjustment (1.4.3) refers to the difference between the measured signal and the actual material height. You may set this value to change the measured value.

Note!

The parameter settings of High/Low Level Adjustment require inputting the distance from the bottom of flange.

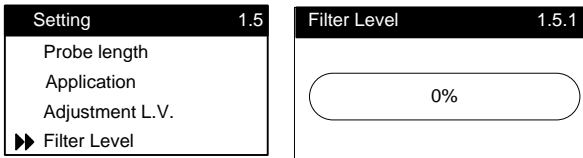

Filter Wave Setting (1.5) menu is used to adjust the filter wave degree of the output signal within 0%~100%, which is applied in fluctuating level. Note that the higher the percentage of the filter wave, the slower the output reaction time is.

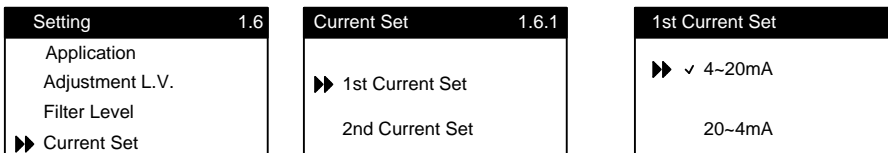

Current Settings (1.6) menu can be divided into 1st current set and 2nd current set. Wherein, the 2nd current set is only available for the models with dual-analog output. In this setting, the user may set the current output to correspond to the distance or the material height, with an output conversion of 4~20mA and 20~4mA.

9.2.2 Display settings Menu

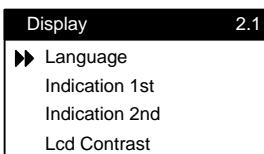

Display Settings (2) menu provides 4 items for setting, with the functions as introduced below:

Language (2.1): It is to set the language shown on the LCM display.

Indication 1st (2.2): It is to set the display content shown on the upper part of the LCM display.

Indication 2nd (2.3): It is to set the display content shown on the lower part of the LCM display.

LCM Contrast (2.4): It is to set the display contrast shown on the LCM display.

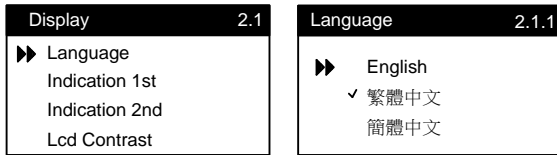

Language (2.1) menu is provided to set the language shown on the LCM display, English/Traditional Chinese/Simplified Chinese are available.



Display Content 1 (2.2) menu allows you to adjust the content shown on the upper part of the LCM display. The content shown on the upper part includes Distance (distance from the reflection plane and the flange reference plane) or Material Height (height between the reflection plane and the probe bottom). The content shown on the lower part includes Distance/Percentage/Current.

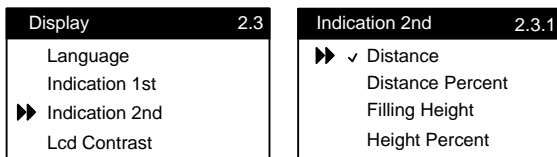

Display Content 2 (2.3) menu allows you to adjust the content shown on the upper part of the LCM display. The content shown on the upper part includes Distance (distance from the reflection plane and the flange reference plane) or Material Height (height between the reflection plane and the probe bottom). The content shown on the lower part includes Distance/Percentage/Current.

Note!

When it is applied in different interfaces, Display Content 2 shows the measured value of the second reflection interface.

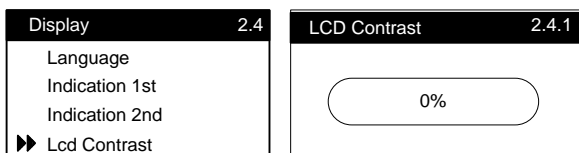

Display Contrast (2.4) menu allows you to adjust the contrast of the LCM display.

9.2.3 Diagnostics

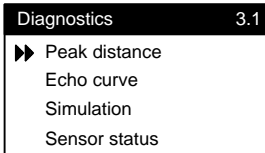

Diagnostics (3) menu provides 6 parameters for setting, with the function as introduced below:

- Peak distance (3.1): It is to query and reset the measured peak value. °
- Echo curve (3.2): It is to view the echo curve of the measured signal.
- Simulation (3.3): It is to simulate the height of the measured media.
- Sensor Status (3.4): It is to view the sensor status.
- Trigger Default (3.5): It is the minimum level of echo signal. °
- Blind Distance (3.6): It is the distance from the bottom of flange that can't be measured.

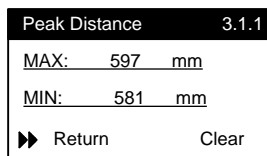
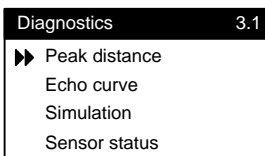

Peak distance (3.1) menu records the measured peak value after startup, which can be queried and reset in this menu.

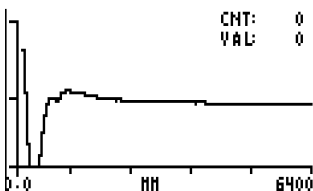

Echo Curve (3.2) menu shows the echo curve that is measured currently.

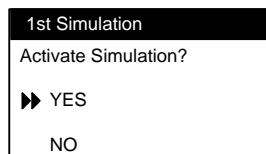
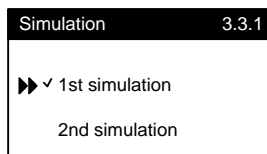
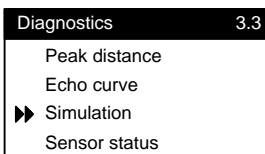

Simulation (3.3) menu provides settings in two phases. The first phase is to select whether to start the simulation function. The second phase is to input the target distance value to be simulated.

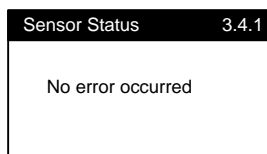
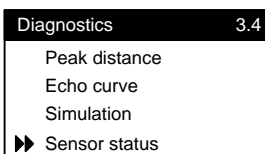

Sensor Status (3.4) menu allows you to query the current instrument status. Under normal status, it shows No Error. After self-diagnosis, it shows error code in case of error.

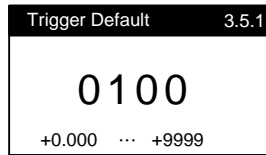
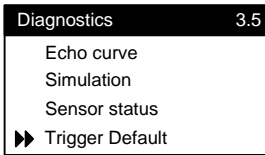

Trigger Default (3.5) menu is to set the minimum level for setting the echo signal.

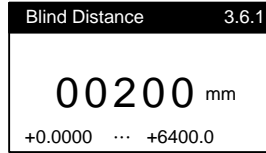
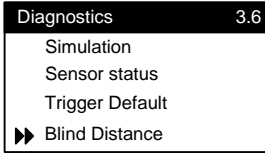

Blind distance(3.6) menu is to set the distance from the bottom of flange that can't be measured (200mm by default).

9.2.4 Additional Settings Menu

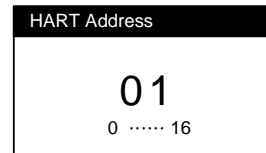
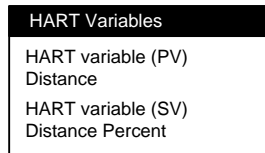
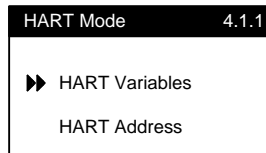
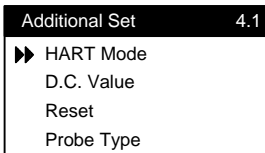

HART Mode(4.1.1) menu, the first layer is divided into HART Variable and HART Address. HART Variable submenu allows you to query the data of 4 HART variables, while HART Address submenu is to set the communication ID.

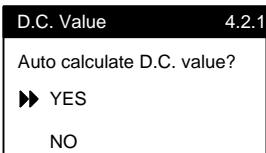
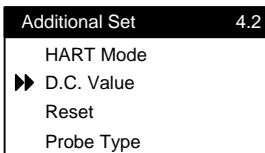

D.C. Value(4.2) menu is to set the dielectric constant of the media. It is used for the bottom tracking probe mode.

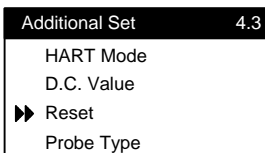

Reset (4.3) menu is to restore to the factory settings. After Yes is pressed, all parameters will be reset.

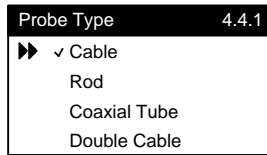
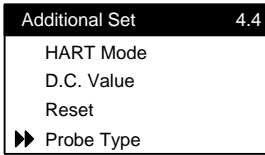

Probe Type (4.4) menu provides the available probe types, Cable, Rod, Coaxial Tube, Double cable and Double Rod.

9.2.5 Product Information Menu

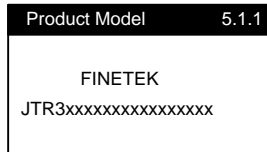
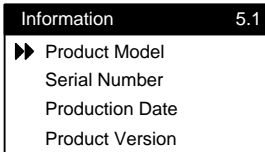

Product Model (5.1) menu allows you to view the product model of the instrument.

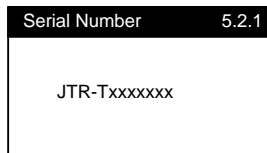
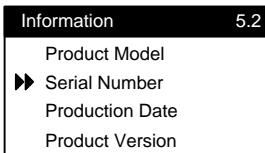

Serial No. (5.2) menu allows you to view the product serial number of the instrument.

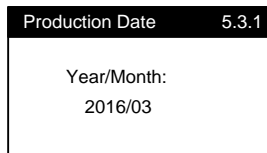
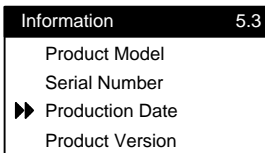

Production Date (5.3) allows you to view the production date of the instrument.

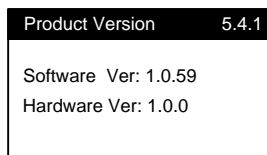
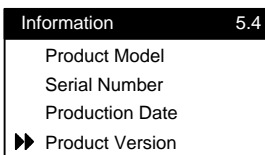

Production Version (5.4) allows you to view the product version of the instrument.

9.3 Parameter table list

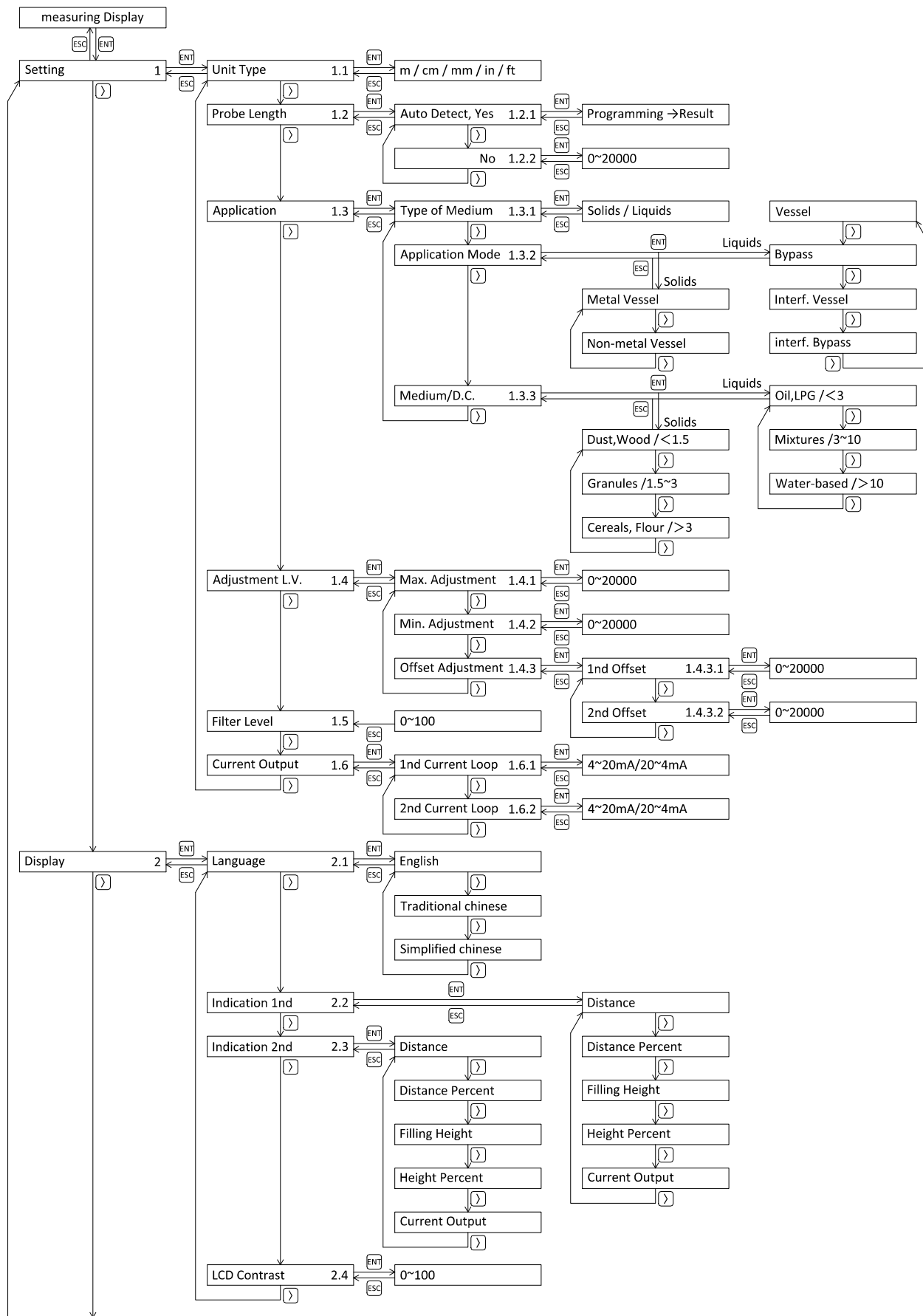

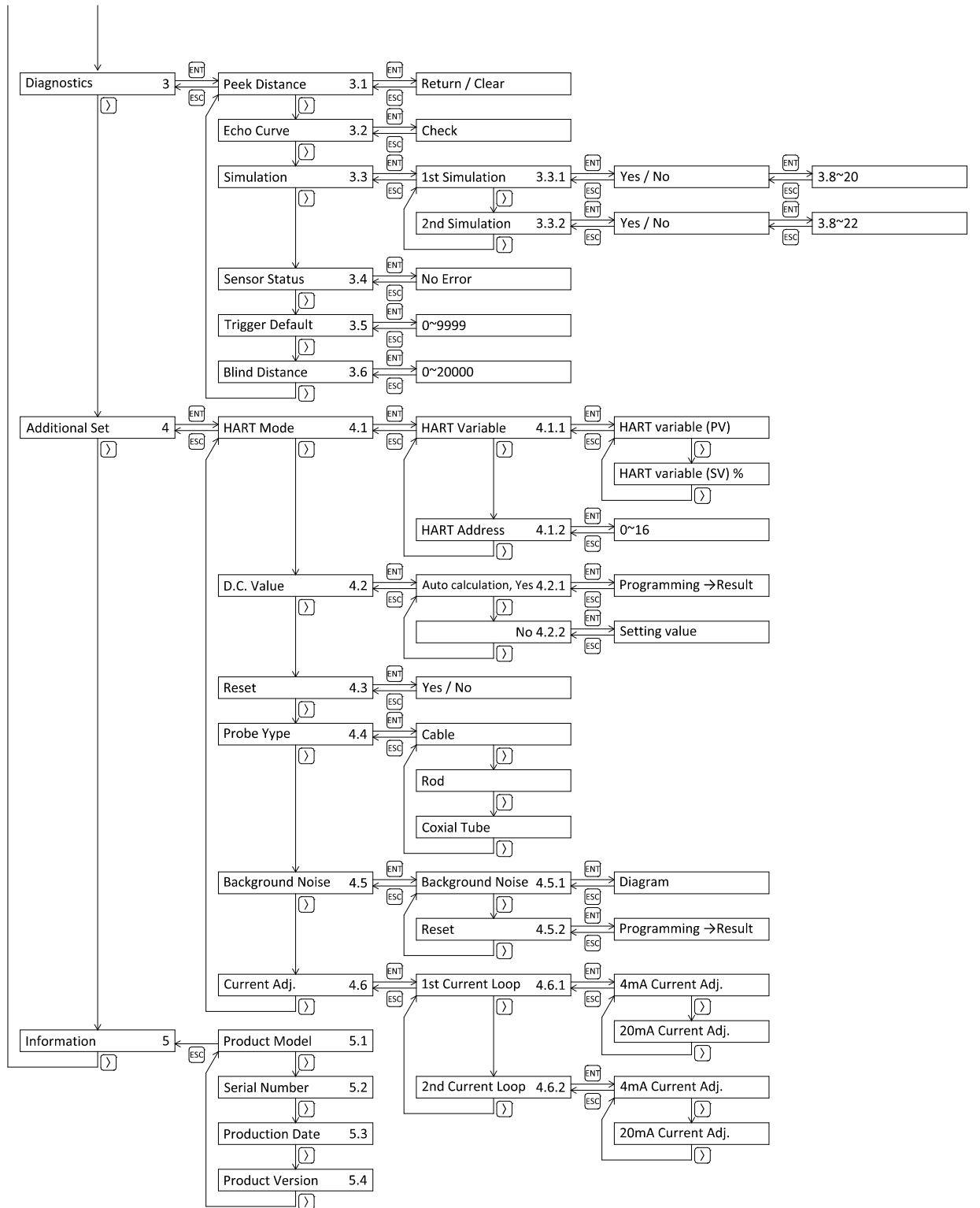

10. Warnings and Cautions

1. Intrinsic safe explosion system must request to use explosion proof model together with safety barriers that complied with Ex ia. So that it can be used in hazardous area.
2. Casing material is Aluminum. Installation should make precaution to prevent burn by shock or rub.
3. Please make precaution to avoid static and burn caused by non-metal material.
4. JTR connect with equipment in non-hazardous area, should follow the user's manual and wire correctly.
5. Shielded cable should be used when connect with external equipment. Shields should be well grounded.
6. Intrinsically safe electric parameter :

Terminal Code (Power)	Max. Voltage Input U_i (V)	Max. Current Input I_i (mA)	Max. Power Input P_i (W)	Max. Internal equivalent parameter	
				C_i (μ F)	L_i (mH)
V1+ , V1- V2+ , V2-	30	100	0.7	0	0
V+ , V-	30	100	0.7	0	0
	10	300			

Terminal Code (RS485)	Max. Voltage U_i (V)	Max. Current I_i (mA)	Max. Power P_i (W)	Max. Internal equivalent parameter	
				C_i (μ F)	L_i (mH)
D+ , D-	12	100	0.3	0	0
	Max. Voltage Output U_o (V)	Max. Current Output I_o (mA)	Max. Power Output P_o (mW)	Max. External Parameter	
	7	15	25	C_o (μ F)	L_o (mH)
See below					

Terminal Code (AO)	Max. Voltage U_i (V)	Max. Current I_i (mA)	Max. Input Power P_i (W)	Max. Internal equivalent parameter	
				C_i (μ F)	L_i (mH)
I+ , I- I2+ , I2-	15	70	0.25	0	0
	Max. Voltage Output U_o (V)	Max. Current Output I_o (mA)	Max. Power Output P_o (W)	Max. External Parameter	
	14	70	0.25	C_o (μ F)	L_o (mH)
See below					

Terminal Code	Total	
	Co (μF)	Lo (mH)
D+ , D- I+ , I- I2+ , I2-	0.5	1.0

7. Customer is not allowed to replace components by themselves. It's requested to contact manufacturer and solve problem together to avoid damage happened.
8. The relationship between ambient temperature and process temperature is as below :

NEPSI :

Temperature Catagories	Ambient Temperature (°C)	Medium(Process) Temperature (°C)
T4	-40~60	-40~130
T3	-40~60	-40~190
T2	-40~60	-40~230

ATEX / IECEX :

Temperature Catagories	Ambient Temperature (°C)	Medium(Process) Temperature (°C)
T6	-40~55	-40~85
T5	-40~70	-40~100
T4	-40~70	-40~135
T3	-40~70	-40~150
T2	-40~70	-40~230

※Actual temperature resistance refers to the latest catalogue and comply with the explosive proof certificate and standards.

9. The product installation, use and maintenance shall follow the user's manual and the following standards :

GB3836.13 (IEC 60079-19) "Electric Apparatus for Explosive Gas Atmospheres Part 13 : Equipment repair, overhaul and reclamation".

GB3836.15 (IEC 60079-14) "Electric Apparatus for Explosive Gas Atmospheres Part 15 : Electrical installations design, selection and erection (Except for Coal Mine)".

GB3836.16 (IEC 60079-17) "Electric Apparatus for Explosive Gas Atmospheres Part 16 : Electrical installations inspection and maintenance (Except for Coal Mine)".

GB3836.18 (IEC 60079-25) "Electric Apparatus for Explosive Gas Atmospheres Part 18 : Intrinsically safe electrical systems".

GB50257 "Electric Equipment Installation Engineering Code for Construction and Acceptance of Electric Device within Explosion and Fire Hazard Environments"

11.Troubleshooting

Abnormal	Cause	Solution
No LCM display No current output.	No power supply.	Check wiring and pin, and repair. Check power supply and open again.
	Power supply spec. is not complied.	Check product spec. and correct.
No LCM display Have current output.	LCM module in bad connection.	Remove LCM first Disconnect the power in 3 seconds and reconnect it again Then install LCM immediately. Contact sales if it's still not solved.
	LCM is not installed for a long time, Instrument not update LCM status.	
Not able to show the correct distance.	Signal is too low.	Press "ESC" to enter reflection page and check "L.V." › Reduce the trigger level under "L.V."
Measure the incorrect position.	Background noise is too big.	Operate and save the background noise under empty tank condition. Contact sales if it's still not solved.

12. Communication Protocol Table

Address	NUM	Format	Parameter	Value range
4103	2	FLOAT32	PFC_DISPLAY_VALUE	0~99999
4106	2	FLOAT32	PFC_2ND_DISPLAY_VALUE	0~99999
4109	2	FLOAT32	PFC_DISTANCE	0~35000
4012	2	FLOAT32	PFC_2ND_DISTANCE	0~35000
4128	4	FLOAT32	PFC_SOFTWARE_VERSION	0~99999
4132	2	FLOAT32	PFC_DISPLAY_VALUE	0~99999
4134	2	FLOAT32	PFC_2ND_DISPLAY_VALUE	0~99999
4136	2	FLOAT32	PFC_DISTANCE	0~35000
4138	2	FLOAT32	PFC_2ND_DISTANCE	0~35000
4140	2	FLOAT32	PFC_DISTANCE_PERCENTAGE	0~100
4142	2	FLOAT32	PFC_2ND_DISTANCE_PERCENTAGE	0~100
4144	2	FLOAT32	PFC_DISTANCE_CURRENT_MA	4~20
4146	2	FLOAT32	PFC_SET2_DISTANCE_CURRENT_MA	4~20
4148	2	FLOAT32	PFC_PEAK_DISTANCE_MAX_VALUE	0~35000
4150	2	FLOAT32	PFC_PEAK_DISTANCE_MIN_VALUE	0~35000
4152	2	FLOAT32	PFC_2ND_PEAK_DISTANCE_MAX_VALUE	0~35000
4154	2	FLOAT32	PFC_2ND_PEAK_DISTANCE_MIN_VALUE	0~35000
4206	12	UINT8	PFC_PRODUCT_MODEL[24]	----
4218	7	UINT8	PFC_PRODUCT_SERIAL[14]	----
4225	4	UINT8	PFC_PRODUCT_DATE[8]	----
4229	4	UINT8	PFC_HARDWARE_VERSION[8]	----
4233	2	FLOAT32	PFC_MIN_LEVEL	0~35000
4235	2	FLOAT32	PFC_MAX_LEVEL	0~35000
4237	2	FLOAT32	PFC_BLIND_DISTANCE	0~35000
4239	2	FLOAT32	PFC_DISTANCE_OFFSET1	-99999~ +99999
4241	2	FLOAT32	PFC_DISTANCE_OFFSET2	-99999~ +99999
4243	2	FLOAT32	PFC_PROBE_LENGTH	0~35000
4245	1	UINT16	PFC_LANGUAGE	0,1,2
4246	1	UINT16	PFC_FILTER_LEVEL	0~100
4247	1	UINT16	PFC_UNIT_TYPE	0,1,2,3,4
4248	1	UINT16	PFC_MATERIAL	0,1
4254	1	UINT16	PFC_DISPLAY_1_CONTEXT	0,1,2,3,4

4255	1	UINT16	PFC_DISPLAY_2_CONTEXT	0,1,2,3,4
4256	1	UINT16	PFC_CURRENT_OUTPUT_MODE_1ST	0~1.0
4257	1	UINT16	PFC_CURRENT_OUTPUT_MODE_2ND	0~1.0
4259	2	FLOAT32	PFC_CAL_MEDIUM_CONST	>1.5
4261	2	FLOAT32	PFC_CAL_LOW_COUNT	0~4096
4263	1	UINT16	PFC_CAL_LOW_POSITION	0~35000
4264	1	UINT16	PFC_CAL_PROBE_END_CNT	0~4096
4265	1	UINT16	PFC_CAL_PROBE_END_VALUE	0~4096
4268	1	UINT16	PFC_4_MA	0~65535
4269	1	UINT16	PFC_20_MA	0~65535
4270	1	UINT16	PFC_SET2_4_MA	0~65535
4271	1	UINT16	PFC_SET2_20_MA	0~65535
4273	1	UINT16	PFC_LOCK_CURRENT_FLAG	0,1
4274	1	UINT16	PFC_SET2_LOCK_CURRENT_FLAG	0,1
4275	2	FLOAT32	PFC_SIMULATED_CURRENT_MA	4~20
4277	2	FLOAT32	PFC_SET2_SIMULATED_CURRENT_MA	4~20
4285	1	UINT16	PFC_MODBUS_ID	1~255
4286	1	UINT16	PFC_MODBUS_BAUDRATE	1200~57600

ООО “РусАвтоматизация”

454010 г. Челябинск, ул. Гагарина 5, оф. 507
 тел. 8-800-775-09-57 (звонок бесплатный), +7(351)799-54-26, тел./факс +7(351)211-64-57
info@rusautomation.ru; русавтоматизация.пф; www.rusautomation.ru