

Laser Displacement Sensor Communication Converter

▣ Features

- Supports RS232C and RS485 communications in one device
 - : Separated ports of RS232C/RS485 for user convenience
- Maximum connection up to 8 amplifier units
- Power supply without extra wiring via amplifier unit
- Dedicated Device Management Program (atDisplacement)
 - : Batch parameter setting via save/load function
 - : Real-time monitoring of measured values and output status
- Communication speed and station number can be set by side DIP switch without connecting host device



 Please read "Safety Considerations" in the instruction manual before using.



▣ Proper Usage

Before using the communication converter unit, depending on the usage environment, keep following items handy. Visit our web site(www.autonics.com) to download.

- atDisplacement program, manual
- SCM-US48I (USB - RS485) Driver, Instruction manual
- BD Series manual
- SCM-38I (RS232C - RS485) Driver, Instruction manual
- SCM-WF48 (Wi-Fi, USB - RS485) Driver, Instruction manual

▣ Manual

For the detail information and instructions, please refer to the manual, and be sure to follow cautions written in the technical descriptions (catalog, website).

Visit our website (www.autonics.com) to download manuals.

▣ Dedicated Device Management Program (atDisplacement)

- atDisplacement is BD-C Series management program for convenient management of multiple device data monitoring.
- Visit our website (www.autonics.com) to download user manual and program.

◎ System requirement

Item	Minimum requirements
System	IBM PC compatible computer with 1GHz + processor
Operations	Microsoft Windows 7 +
Memory	2GB +
Hard disk	1GB + of available hard disk space
VGA	Resolution: 1920×1080 or higher
Others	RS-232 serial port (9-pin), USB port

Laser Displacement Sensor Communication Converter

Product Composition

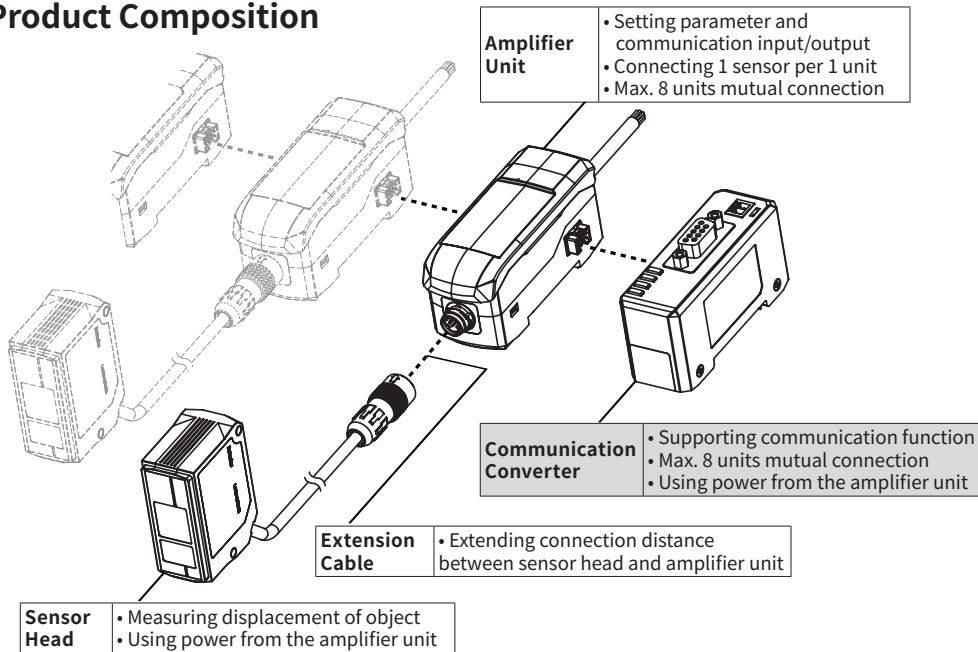

Specifications

BD-C Series Communication Converter		
Model	BD-CRS	
Power supply ^{※1}	—	
Power consumption	Max. 2.3W	
Communication function	RS-232C, RS-485	
Communication speed	9600, 19200, 38400, 115200bps (default)	
Indication	4 LED status indicators	
Function	<ul style="list-style-type: none"> • Real-time monitoring • Executes every BD-Series feature and sets parameter by external device (Master) 	
Environment	Ambient temperature	-10 to 50°C, Storage: -15 to 60°C
	Ambient humidity	Under 85%RH, Storage: under 85%RH
Vibration	1.5mm amplitude at frequency of 10 to 55Hz (for 1 min) in each X, Y, Z direction for 2 hours	
Shock	300m/s ² (approx. 50G) in each X, Y, Z direction for 3 times	
Protection structure	IP40 (IEC Standards)	
Material	Case: Polycarbonate	
Accessory	Side connector, Connector for RS485	
Sold separately	Communication converter (SCM-38I, SCM-US48I, SCM-WF48)	
Approval	CE, RoHS, REACH	
Weight ^{※2}	Approx. 91g (approx. 49g)	

※1: Using power from the amplifier unit. To use BD-C Series communication converter, the amplifier unit needs 12-30VDC power supply.

※2: This weight is with packaging and the weight in parentheses is only unit weight.

※The temperature or humidity mentioned in Environment indicates a non freezing or condensation environment.

■ Unit Description

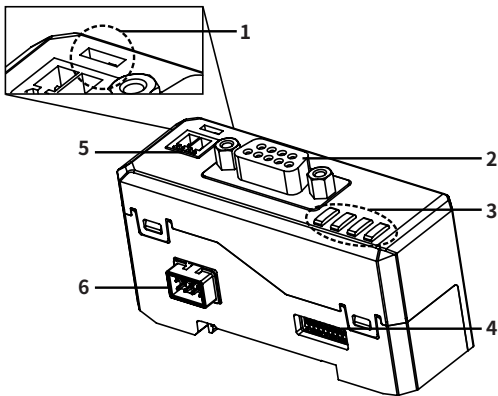

1 RS485 Terminating Switch

Set the switch to 'RT' when the communication converter is connected to the terminal of RS485 communication connection.

2 RS232C Connector

A connector for RS232C communication.

3 Status Indicator

Displays power, communication input/output/error.

- Power indicator (POWER, Green): Displays power supply.
- Communication output indicator (TX, Green): Displays communication output status from communication converter to external device.
- Communication input indicator (RX, Green): Displays communication input status from communication converter to external device.
- Communication error indicator (ERROR, Red): Displays the communication status of communication converter.

4 Communication Setting Switch

Sets communication speed, address, parity bit and stop bit.

5 RS485 Connector

A connector for RS485 communication.

6 Side Connector

A connector for connecting between communication converter and amplifier unit.

■ Dimensions

(unit: mm)

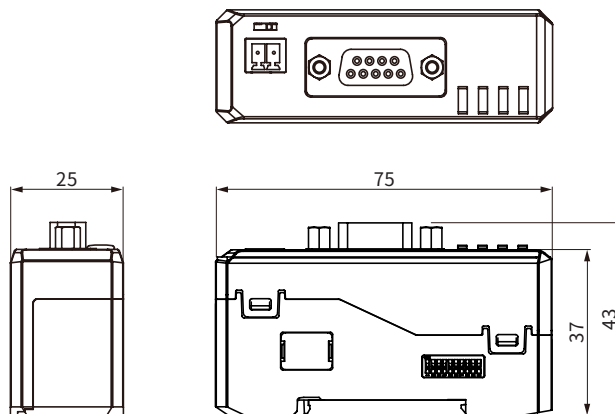

Laser Displacement Sensor Communication Converter

■ Connections

◎ RS232C communication

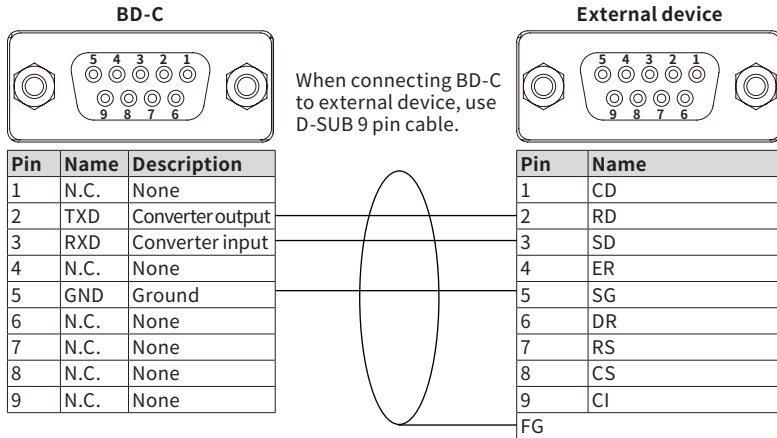

◎ RS485 communication

• Application of system organization

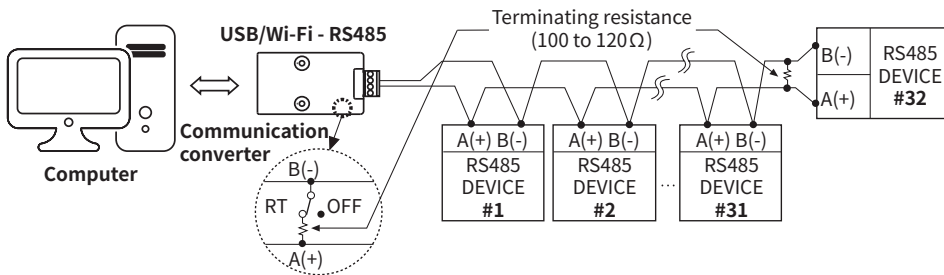

• Terminating switch



Set the switch to 'RT' when the communication converter is connected to the terminal of RS485 communication connection, and set to 'OFF' when it is in the middle of the communication connection.

• Communication pin

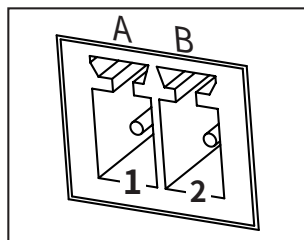

Pin	Name	Description
1	A(+)	RS485 + signal
2	B(-)	RS485 - signal

■ Communication Setting

○ Communication setting switch

※Default: All switches OFF

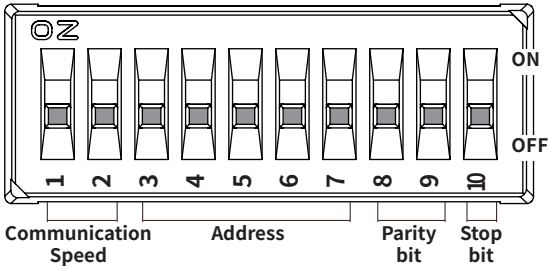

Communication speed (Switch 1, 2): Sets RS-232C, RS-485 communication speed to external device.		
Communication speed	Switch 1	Switch 2
9600bps	ON	ON
19200bps	OFF	ON
38400bps	ON	OFF
115200bps	OFF	OFF

Address (Switch 3 to 7): Sets the address of communication converter.
It is calculated in binary according to the ON/OFF status of each switch.

Switch No.	Switch3	Switch4	Switch5	Switch6	Switch7	Address
Binary digit OFF=0 ON=1	2^4	2^3	2^2	2^1	2^0	Address=Switch 3× 2^4 +Switch 4× 2^3 +Switch 5× 2^2 + Switch 6× 2^1 +Switch 7× 2^0 +1
Address 1	OFF	OFF	OFF	OFF	OFF	$1=0\times 2^4+0\times 2^3+0\times 2^2+0\times 2^1+0\times 2^0+1$
Address 2	OFF	OFF	OFF	OFF	ON	$2=0\times 2^4+0\times 2^3+0\times 2^2+0\times 2^1+1\times 2^0+1$
Address 3	OFF	OFF	OFF	ON	ON	$3=0\times 2^4+0\times 2^3+0\times 2^2+1\times 2^1+1\times 2^0+1$
...
Address 16	ON	OFF	ON	ON	ON	$16=1\times 2^4+0\times 2^3+1\times 2^2+1\times 2^1+1\times 2^0+1$
...
Address 31	ON	ON	ON	ON	OFF	$31=1\times 2^4+1\times 2^3+1\times 2^2+1\times 2^1+0\times 2^0+1$
Address 32	ON	ON	ON	ON	ON	$32=1\times 2^4+1\times 2^3+1\times 2^2+1\times 2^1+1\times 2^0+1$

Parity bit (Switch 8, 9): Sets parity bit for RS-232C, RS-485 communication.

Parity	Switch 8	Switch 9
Even	ON	ON
Odd	OFF	ON
None	ON	OFF
None	OFF	OFF

Stop bit (Switch 10): Sets stop bit for RS-232C, RS-485 communication.

Stop bit	Switch 10
2-bit	ON
1-bit	OFF

Laser Displacement Sensor Communication Converter

■ Installations

◎ Mounting on DIN rail

● Mounting

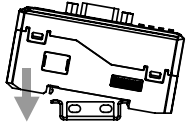

- ① Insert bottom holder of communication converter to 35mm width DIN rail.
- ② Push the front part of the unit to arrow direction to mount.

● Detaching

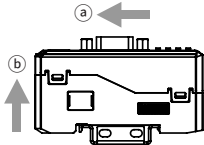

- ① Slide amplifier unit to ① direction.
- ② Pull the assembly part to ② direction to detach.

◎ Connecting to amplifier unit

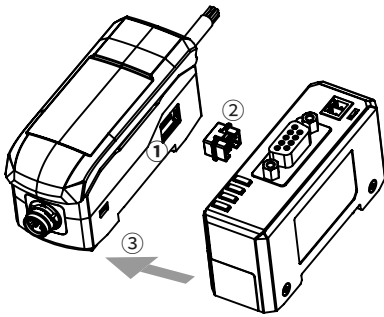

- ① Remove the side cover at the connecting side.
 - ② Connect the side connector to the units.
 - ③ After mounting amplifier unit and communication unit on DIN rail, push it to arrow direction tightly.
- ※In case of disconnecting, follow the upper sequence reversely.

◎ Communication system composition

● Distinguishing master/slave amplifier units

- When the power cable direction is down, the amplifier at the left end is the master unit, and the channel number of slaves increases sequentially to the right. Communication converter is connected to the left side of master amplifier unit.

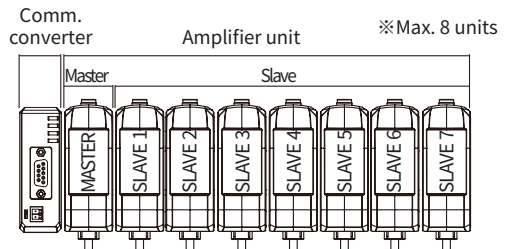

● Precautions when connecting amplifier unit

- Mount on DIN rail.
- Do not supply the power when adding amplifier unit.
- Supply power to each connected amplifier unit at the same time.
- Up to 8 amplifier units can be connected, and only 1 calculation function can be performed per 1 group of mutually connected amplifiers.
- When the calculation function is activated, the setting values (SV) of the slave units are disabled and the mutual interference prevention function for sensor heads is executed automatically.

■ Status Indicators

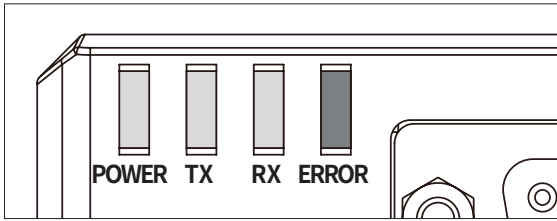

Power indicator (POWER): Green, Displays power supply.

Status	Reason	Solution
On	Power is supplied.	–
Off	Power is not supplied.	After checking the connection between communication converter and amplifier unit correctly, reconnect the device.

Communication output indicator (TX): Green, Displays communication output status from communication converter to external device.

Status	Reason	Solution
Flashing	Signal is outputting.	–
Off	Signal is not outputting.	–

Communication input indicator (RX): Green, Displays communication input status from communication converter to external device.

Status	Reason	Solution
Flashing	Signal is inputting.	–
Off	Signal is not inputting.	–

Communication error indicator (ERROR): Red, Displays the communication status of communication converter.

Status	Reason	Solution
On	Connection is bad between communication converter and amplifier unit.	After checking the connection between communication converter and amplifier unit correctly, reconnect the device.
Flashing	Communication is bad between communication converter and amplifier unit.	After checking the connection between communication converter and amplifier unit correctly, reconnect the device.
		Apply noise prevention to communication converter and amplifier unit.
Off	Operation is normal.	–

■ Cautions during Use

1. Follow instructions in 'Cautions during Use'. Otherwise, it may cause unexpected accidents.
2. Do not install where strong magnetic or electric field exist. Otherwise, the resolution may be adversely affected.
3. Wire as short as possible and keep away from high voltage lines or power lines, to prevent surge and inductive noise.
4. For the optimized performance, it is recommended to measure after 30 minute from supplying power.
5. When detecting with the maximum sensitivity, an error may occur depending on each characteristic deviation.
6. This unit may be used in the following environments.
 - ①Indoors/Outdoors (in the environment condition rated in 'Specifications')
 - ②Altitude max. 2,000m
 - ③Pollution degree 2
 - ④Installation category II