

**NOVOSTRICTIVE
Transducer
Touchless**

TM1

Plug-in Flange

4 ... 20 mA

Mobile Applications

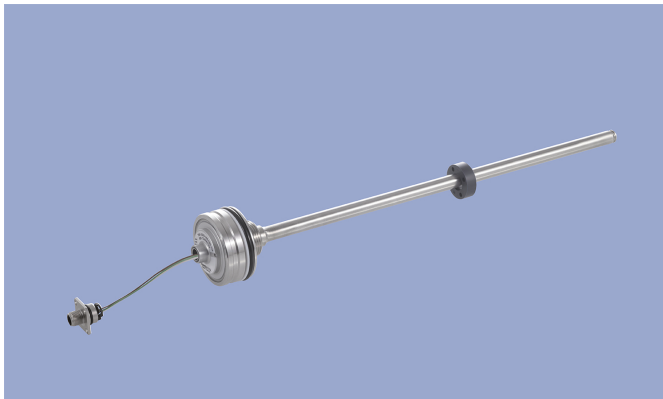
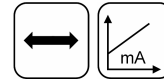

Special Features

- For integration in pneumatic and hydraulic cylinders
- Touchless magnetostrictive measurement technology
- Operating pressure up to 350 bar, peaks up to 450 bar
- Ring-shaped position marker does not contact sensor
- Unlimited mechanical life
- No velocity limit for position marker
- Absolute output
- Outstanding accuracy performance up to 0.04 %
- Wide range of supply voltage
- Optimized for use in mobile applications with highest EMC requirements such as ISO pulses and high interferences to ISO 11452, exceeds E1 requirements
- Other configurations see separate data sheets

Applications

Hydraulic or pneumatic cylinders in

- Agricultural and forestry machinery
- Construction machines
- Vehicles with loading and unloading devices
- Vehicles with extension arms

The absolute position transducer can be used directly in-cylinder and thus enables a compact and cost-effective position measurement. The sensor consists of a stainless steel flange welded to a pressure tight rod and can therefore be used in harsh environments.

The magnetostrictive measuring technology offers excellent accuracy for measuring lengths up to 2000 mm. The passive ring-shaped position marker allows a mechanically decoupled measurement.

Description

Material	Flange: SS 1.4307 / AISI 304L
	Flange cover: AISiMgBi
	Rod: SS 1.4571 / AISI 316Ti
	Sealing: O-ring FKM 80, Supporting ring: PTFE
Mounting	Plugged into cylinders, secured in position with set screw M5 ISO 4026
Electrical connection	Connector M12x1, A-coded / Cable 3x 0.5 mm ² (AWG 20), PUR, unshielded / Connector system M12x1, A-coded with lead wires

Mechanical Data

Dimensions	See dimension drawing
------------	-----------------------

Ordering Specifications

Ordering specifications

Preferred types printed in bold

T	M	1	-	0	5	0	0	-	3	0	5	-	8	2	1	-	4	4	2	
Series			Electrical measuring range Standard lengths 0050 up to 2000 mm in 25 mm-steps Other lengths on request						Mechanical version 305: Plug-in flange Ø 48 mm 307: Plug-in flange Ø 48 mm with internal thread M4x6 at rod end, additional length 7.5 mm			Supply voltage U_b 8: $U_b = 12/24$ VDC		Output signal 2: 4 ... 20 mA		Output characteristic 1: Rising output characteristic, seen from flange 2: Falling output characteristic, seen from flange		Electrical connection 104: Connector M12x1, 4-pin 251: Cable, 3-pole, unshielded, 1 m 253: Cable, 3-pole, unshielded, 3 m 255: Cable, 3-pole, unshielded, 5 m 438: Plug system M12x1, 4-pin, with lead wires 80 mm 442: Plug system M12x1, 4-pin, with lead wires 120 mm 446: Plug system M12x1, 4-pin, with lead wires 160 mm 450: Plug system M12x1, 4-pin, with lead wires 200 mm 454: Plug system M12x1, 4-pin, with lead wires 240 mm		

Drawing

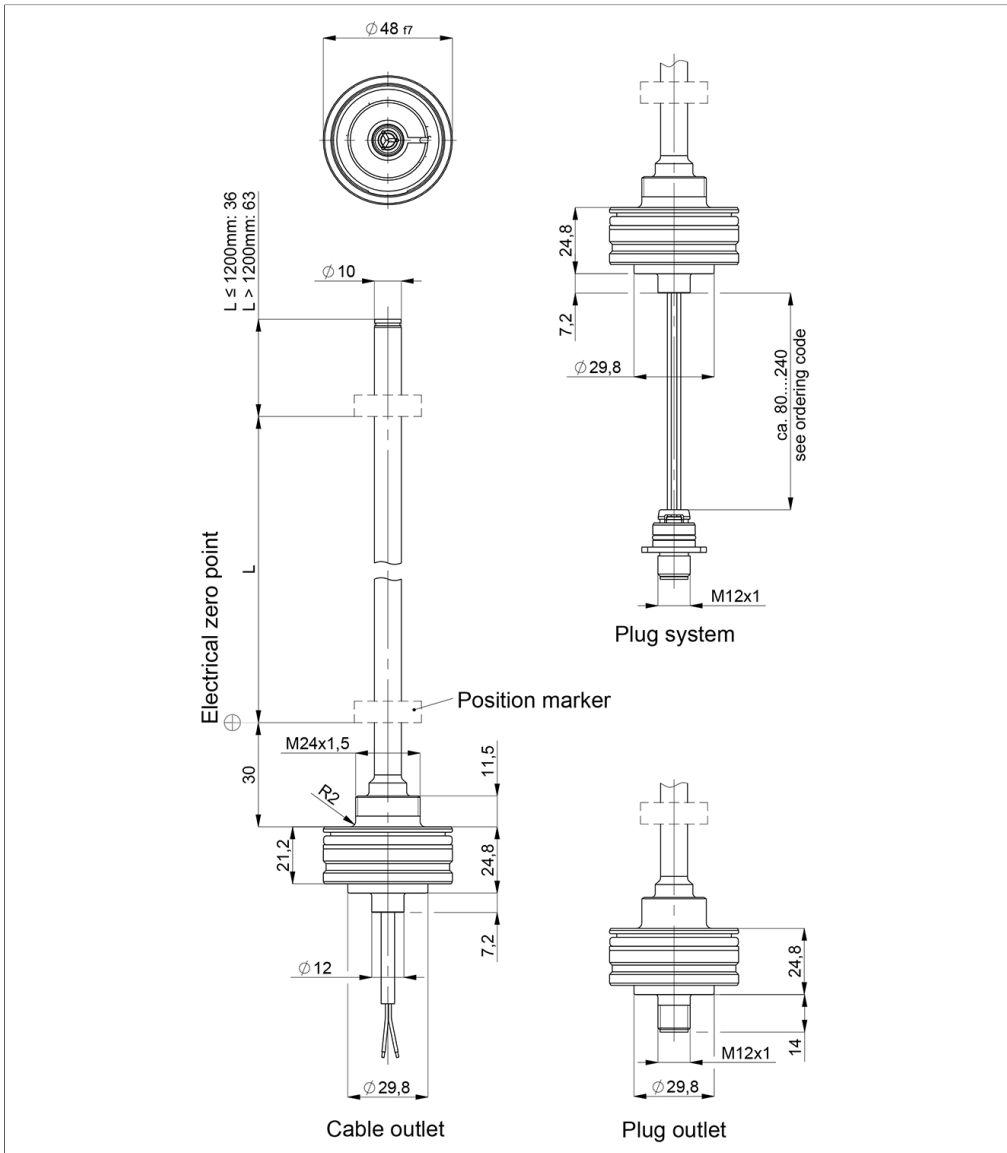

CAD data see
www.novotechnik.de/en/download/cad-data/

Technical Data

Type	TM1-____-305-82-_-_-
Output signal	4 ... 20 mA
Burden	@Ub 24 V: ≤ 500 Ω, @Ub 12 V: ≤ 250 Ω
Sampling rate / Update rate	0.5 kHz
Electrical measuring range (dim. L)	0 ... 50 mm up to 0 ... 2000 mm
Absolute linearity	≤ ±0.04 %FS (min. 300 μm)
Tolerance of electr. zero point	±1 mm
Resolution	≤ 0.1 mm
Repeatability	≤ ±0.1 mm
Hysteresis	≤ ±0.1 mm
Temperature error	typ. 50 ppm/K (min. 0.01 mm/K)
Supply voltage Ub	12/24 VDC (8 ... 32 VDC)
Supply voltage ripple	≤ 10% Ub
Power drain w/o load	< 1 W
Overvoltage protection	36 VDC (permanent)
Polarity protection	yes (-36 VDC)
Short circuit protection	yes (output vs GND and supply voltage up to 36 VDC)
Insulation resistance (500 VDC)	≥ 10 MΩ
Environmental Data	
Max. operational speed	Mechanically unlimited
Vibration IEC 60068-2-6	20 g, 10 ... 2000 Hz, Amax = 0.75 mm
Shock IEC 60068-2-27	100 g, 11 ms (single hit)
Protection class DIN EN 60529	IP67 (Connector system M12, fastened, when correctly fitted in cylinder: IP69)
Operating temperature	-40 ... +105°C (connector M12 / Kabel), -40 ... +85°C (connector system M12)
Operating humidity	0 ... 95 % R.H. (no condensation)
Working pressure	≤ 350 bar
Pressure peaks	≤ 450 bar
Burst pressure	> 700 bar
Life	Mechanically unlimited
Functional safety	If you need assistance in using our products in safety-related systems, please contact us
MTTF (IEC 60050)	355 years
EMC Compatibility	
ISO 10605 ESD (Handling/Component)	8 kV / 15 kV
ISO 11452-2 Radiated HF-fields	100 V/m
ISO 11452-5 Radiated HF-Fields, stripline	200 V/m
CISPR 25 Radiated emission	Level 4
ISO 7637-2 Pulses on supply lines	(1, 2a, 2b, 3a, 3b) Level 4
ISO 16750 Pulses on supply lines	(4, 5) Level 4
ISO 7637-2 Transient Emissions	Level 3
ISO 7637-3 Pulses on output lines	Level 4
EN 13309 Construction machinery	
ISO 14982 Agricult./forestry machines	
The EMC measurements are conducted in a reference cylinder. The EMC properties can deviate when using different cylinders.	

Connection Assignment

Signal	Connector code 1__	Cable code 2__	Plug system code 4__
Supply voltage Ub	Pin 1	BN	Pin 1
GND	Pin 3	WH	Pin 3
Signal output	Pin 2	GN	Pin 2
Do not connect	Pin 4	-	Pin 4

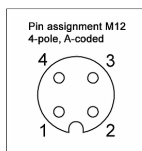

**Technical Data
Output
Characteristics**

Output characteristic

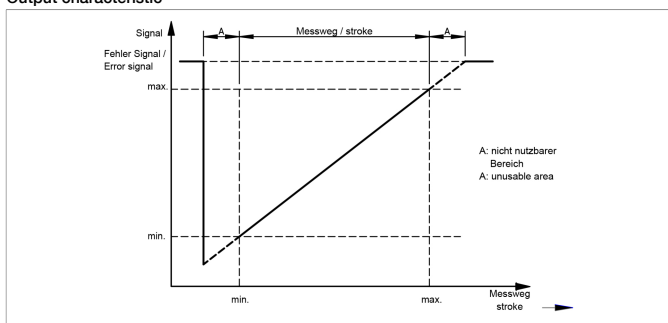

Output characteristic

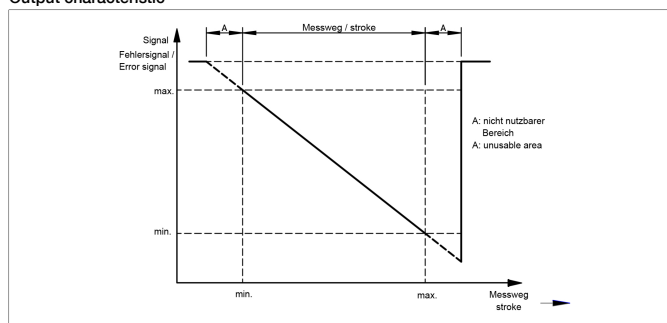

Position Markers

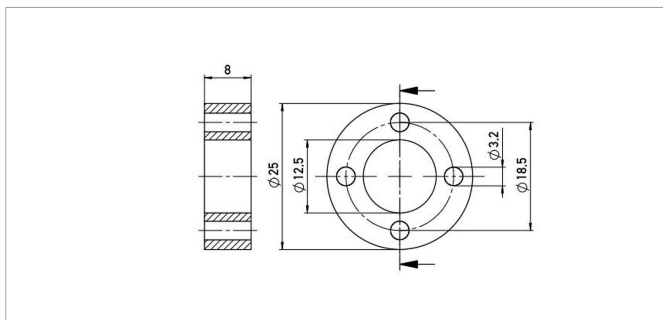

Z-TH1-P18

Ring position marker for fixation with screws M3
 Material PA6-GF
 Weight approx. 12 g
 Operating temp. -40 ... +100°C
 Surface pressure max. 40 N/mm²
 Fastening torque max. 100 Ncm
 of mounting

P/N	Pack. unit [pcs]
400005697	1

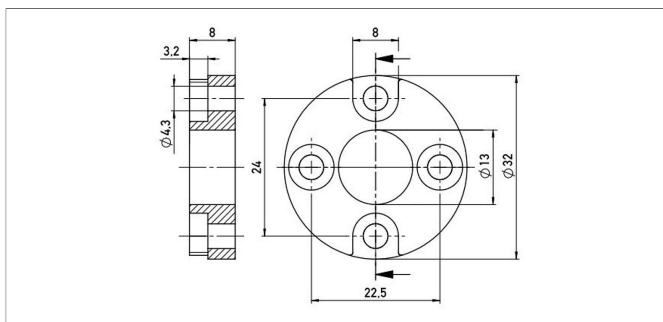

Z-TH1-P19

Ring position marker for fixation with screws M4
 Material PA6-GF
 Weight approx. 14 g
 Operating temp. -40 ... +100°C
 Surface pressure max. 40 N/mm²
 Fastening torque max. 100 Ncm
 of mounting

P/N	Pack. unit [pcs]
400005698	1

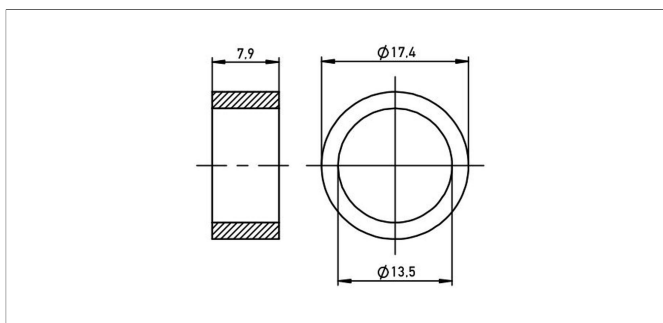
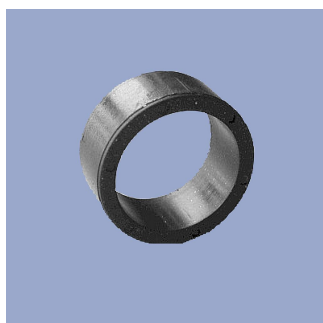

Z-TIM-P20

Ring position marker for mounting via lock washer and retaining ring
 Material PA-Neonbond Compound
 Weight approx. 5 g
 Operating temp. -40 ... +100°C
 Surface pressure max. 10 N/mm²

P/N	Pack. unit [pcs]
400005699	1

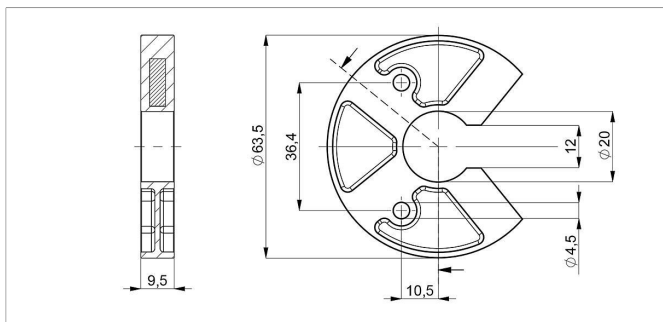

Z-TH1-P25

U-shaped position marker for fixation with M4 screws
 Caution: for dimension of electrical zero point please follow the user manual!
 Material PA6-GF
 Operating temp. -40 ... +105°C
 Surface pressure max. 40 N/mm²
 Fastening torque max. 100 Ncm
 of mounting

P/N	Pack. unit [pcs]
400105076	1

Position Markers

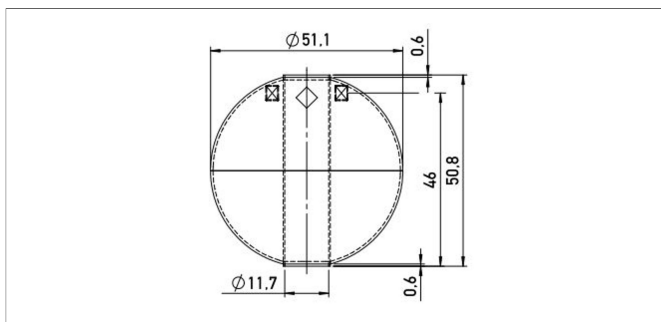

Z-TH1-P22

Ball-type floating position marker
Material SS 1.4571 / AISI 316Ti
Weight approx. 42 g
Operating temp. -40 ... +100°C
Compression strength ≤ 60 bar
Density 720 kg/m³
Immersion depth in water 36.7 mm

P/N	Pack. unit [pcs]
400056045	1

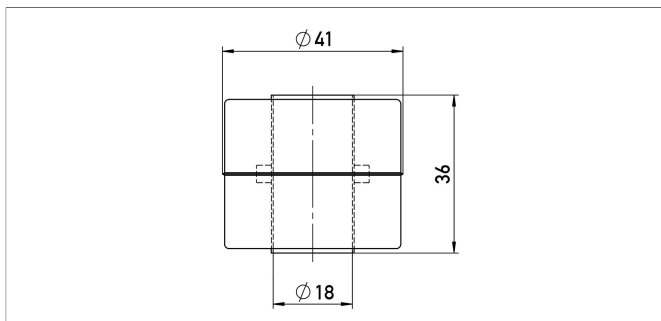

Z-TH1-P21

Cylinder floating position marker
Material SS 1.4404 / AISI 316L
Weight approx. 20 g
Operating temp. -40 ... +100°C
Compression strength ≤ 8 bar
Density 740 kg/m³
Immersion depth in water approx. 26.6 mm

P/N	Pack. unit [pcs]
400056044	1

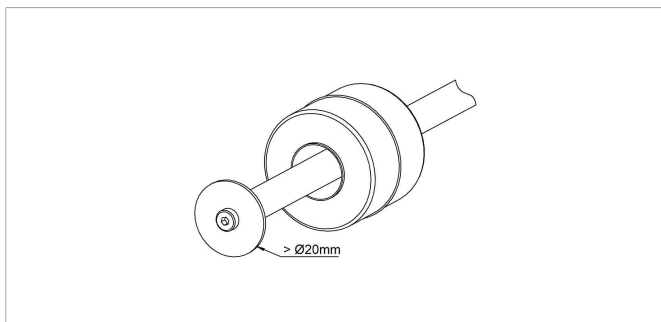

Floating Position Marker - Installation Recommendation

When using floating position markers, we recommend to secure the marker against loss with a washer at the rod end.

For this purpose, a sensor version with inner thread at the rod end is required (s. ordering code).

Connector System M12

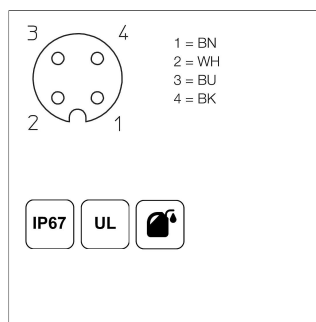
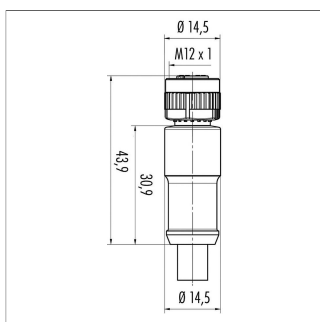

EEM-33-35/36/37
M12x1 Mating female connector, 4-pin, straight, A-coded, with molded cable, not shielded, IP67, open ended
Plug housing PA
Cable sheath PUR, \varnothing = max. 6 mm, -40 ... +85°C (fixed)
Lead wires PP, 0.34 mm²

P/N	Type	Length
400056135	EEM-33-35	2 m
400056136	EEM-33-36	5 m
400056137	EEM-33-37	10 m

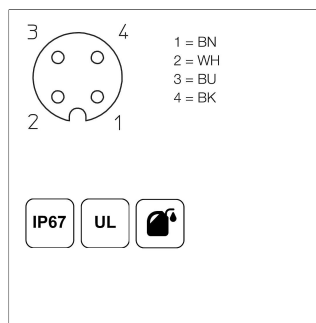
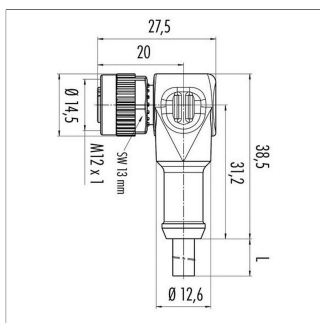

EEM-33-38/39/40
M12x1 Mating female connector, 4-pin, angled, A-coded, with molded cable, not shielded, IP67, open ended
Plug housing PA
Cable sheath PUR, \varnothing = max. 6 mm, -40 ... +85°C (fixed)
Lead wires PP, 0.34 mm²

P/N	Type	Length
400056138	EEM-33-38	2 m
400056139	EEM-33-39	5 m
400056140	EEM-33-40	10 m

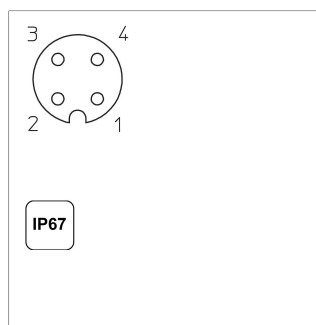
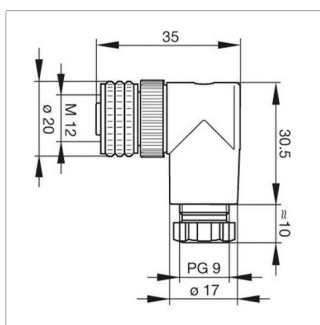

EEM-33-89
M12x1 Mating female connector, 4-pin, angled, A-coded, with coupling nut, screw termination, IP67, not shieldable
Included in delivery
Operating temp. -25 ... +90°C
Plug housing PBT
For wire gauge 6 ... 8 mm, max. 0.75 mm²

P/N	Type
400005634	EEM-33-89

IP67 Protection class IP67 DIN EN 60529

IP68 Protection class IP68 DIN EN 60529

Very good Electromagnetic Compatibility (EMC) and shield systems

Very good resistance to oils, coolants and lubricants

Suited for applications in dragchains

UL UL - approved

CAN-Bus