

ProSens

Dust Measurement

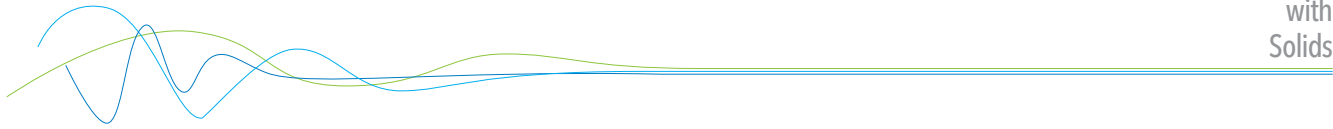



CONTENTS	Page
1. Introduction	3
1.1 Safety	3
1.2 Product overview	3
1.3 Mode of operation	3
2. Installation	4
2.1 Selection of the sensor location	4
2.2 Sensor installation	6
3. Safety	7
3.1 Normal use	7
3.2 Identification of hazards	7
3.3 Operational safety	7
3.4 Technical statement	7
4. Electrical connection	8
4.1 Sensor connection	8
4.2 PME transmitter	9
4.3 DIN Rail Transmitter	10
4.4 Connecting multiple sensors using the C3-box	11
4.5 Use in Ex hazardous areas	12
5. Dimensions	13
5.1 Sensor	13
5.2 PME Transmitter	13
5.3 DIN Rail Transmitter	14
5.4 Dimensions C1-box (optional)	14
5.5 Dimensions C3-box (optional)	15
6. Operation	15
6.1 Basic operation of the PME-touchscreen	15
6.2 Basics for PC configuration	16
6.3 Configuration	17
7. Fitting up to 3 sensors	20
8. Maintenance	21
9. Warranty	21
10. Troubleshooting	21
10.1 Alarm relay does not work	21
10.2 No measured value, even so after calibration	21
11. Technical data	22

1. Introduction

1.1 Safety

ProSens requires 24 ±10 % V DC power supply. 24 ±10 % V DC voltage level is considered as safe.
DIN Rail Converter requires 24 ±10 % V DC power supply. 24 ±10 % V DC voltage level is considered as safe.

Caution:

The duct has to be exposed to a clean atmosphere during installation.
As such, the following should be considered:

- The gas flows or dust can be hazardous.
- Those flow can be inflammable, explosive, etc.
- The gases can be hot or under pressure.

1.2 Product overview

The ProSens dust measurement systems are microprocessor-based and are pre-adjusted instruments for measuring dust burdens in an airstream. ProSens is designed to monitor the clean air section behind filter components and for measuring dust concentration in exhaust air ducts.

It is a compact unit consisting of a sensor and transmitter, enclosed in an IP 66 enclosure, which has been specifically designed for easy installation and operation.

The standard transmitter is enclosed in the IP 65 housing and incorporates a touchscreen.
A DIN Rail Transmitter is also available, which is configured using the PC software.

The PME provides USB and RS 485 interfaces for PC configuration, the DIN Rail version can communicate via RS 232 or RS 485 interfaces.

The PC software allows for configuration and calibration, which included the setting of internal parameters like filter time, alarm hold time, etc.

With the software it is possible to monitor signal trends and to log protocol files.

ProSens is designed process pressures up to 2 bars and process temperature up to 250 °C.
An optional version is to be used in EX-zones category 1/2 gas & dust.

The sensor is connected to the transmitter using a 4 wire cable.

1.3 Mode of operation

ProSens utilises tribo-electric technology whereby the interaction of dust particles with the sensor rod causes a small electric charge, when the particles pass or hit by the sensor rod.

This small electric charge generates a signal proportional to the dust level even with an accumulation of particles on the sensor rod. Experience has shown that this method of sensing dust level in gases offers accurate results with a minimum of maintenance.

With power applied the unit is ready-to operate using factory setting and can be configured and calibrated using the PME or PC software. For DIN Rail versions a PC is required for commissioning. Programmable maximum & minimum alarm outputs are available. If the relay is used as “normally closed” (NC), the sensor is also monitored for power failures. Also any other failure will be activated.

The transmitter has a 4 ... 20 mA output proportional to the trend of the dust burden.
If there is an error found by internal system checks the output is set to 2 mA.

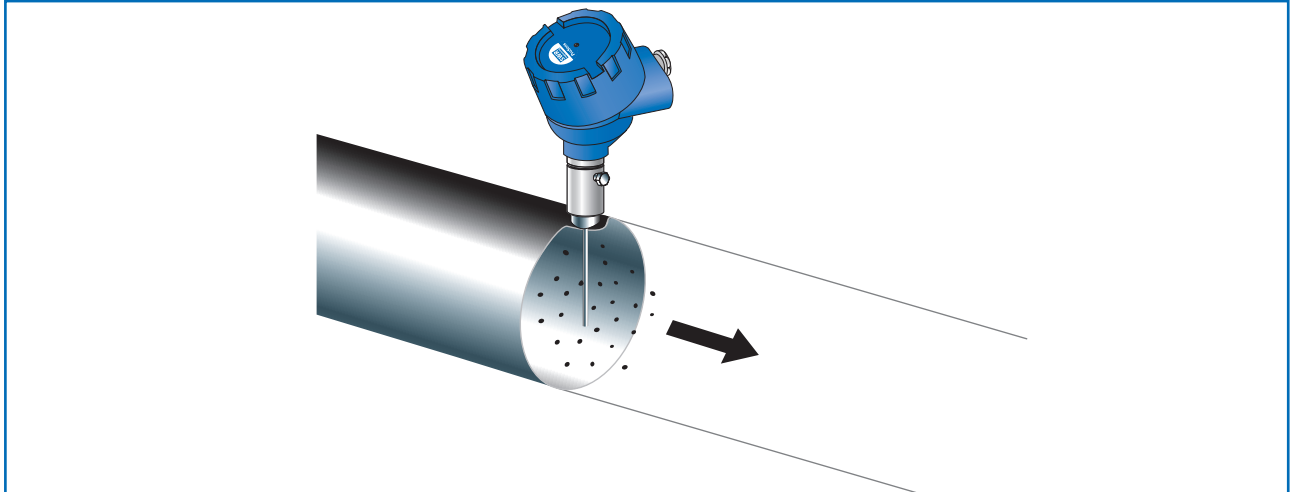

Fig. 1

2. Installation

2.1 Selection of the sensor location

The best location for installation of the ProSens is in a duct section where there is even laminar flow distribution.

The optimal position would be in a horizontal or vertical section of the duct. There should not be bends, valves, dampers or other obstructions, either upstream or downstream, for a distance of at least 5 times the pipe/duct parameters. (See figure 2)

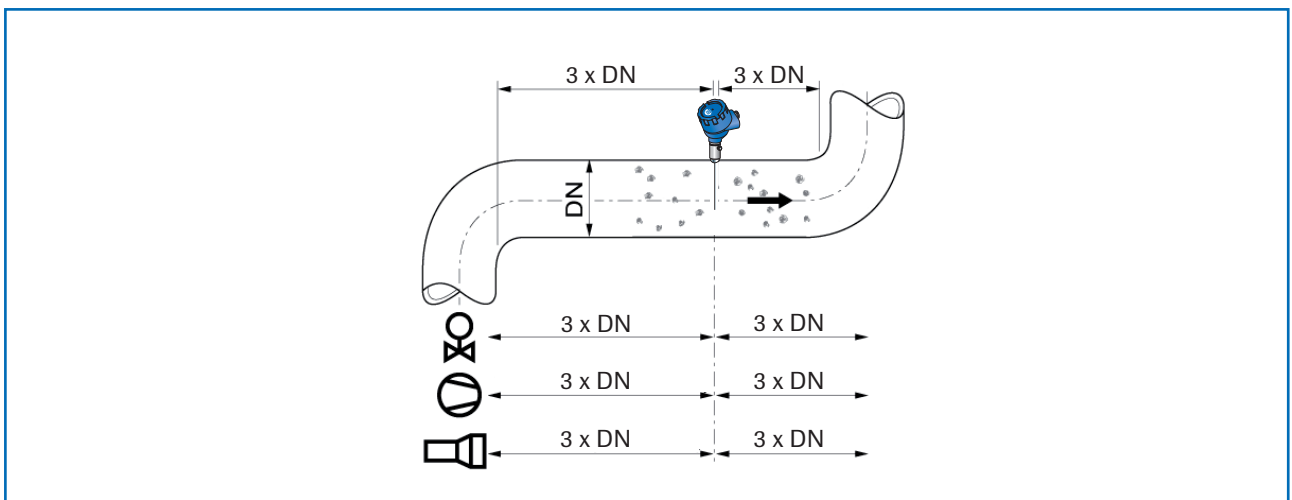

Fig. 2: Recommended distances to bends (DN = duct diameter)

In some applications a compromise has to be made and the sensor will have to be fitted in a position that satisfies the majority of above requirements.

The sensor has to be attached to metal ductwork so that it will be electrically shielded from interference and be provided with good grounding. For non-metal ducts, a section of the duct, a minimum of 5 x diameters in length, should be covered with a metallic foil or fine-mesh on the periphery of the duct.

Caution, ensure good grounding practice are adhered to.

1. The unit should be installed in a position, where the gas flow passes the sensor rod at an angle of 90°.
2. In round cross-section ducts the unit can be installed in any position above the horizontal axis (between 9 and 3 o'clock). (See figure 3a)
3. For square cross-section ducts, the unit must be positioned in the middle of the top or in the middle of one of the sides. (See figure 3b)
4. Although the sensor is not affected by vibration, very high vibration levels should be avoided.
5. The units should not be installed in direct sunlight or in areas where the ambient temperature is above 60 °C.
6. The sensor rod must not contact the opposite duct wall or any other obstacle inside the duct!
The sensor can be shortened to a minimum length of 70 mm. Be careful not to damage the plastic cap when doing this.
 - The length of the sensor rod should at least $\frac{1}{3}$ and at most $\frac{2}{3}$ of the channel diameter, ensuring there is no contact with the opposite wall.
 - The smaller the dust burden, the longer the antenna should be.
7. When monitoring an electrical filter system, the minimum distance from the filter is 20 m.
Although vibration does affect the measurement, the sensor should not be subjected to excessive vibration for long periods of time.

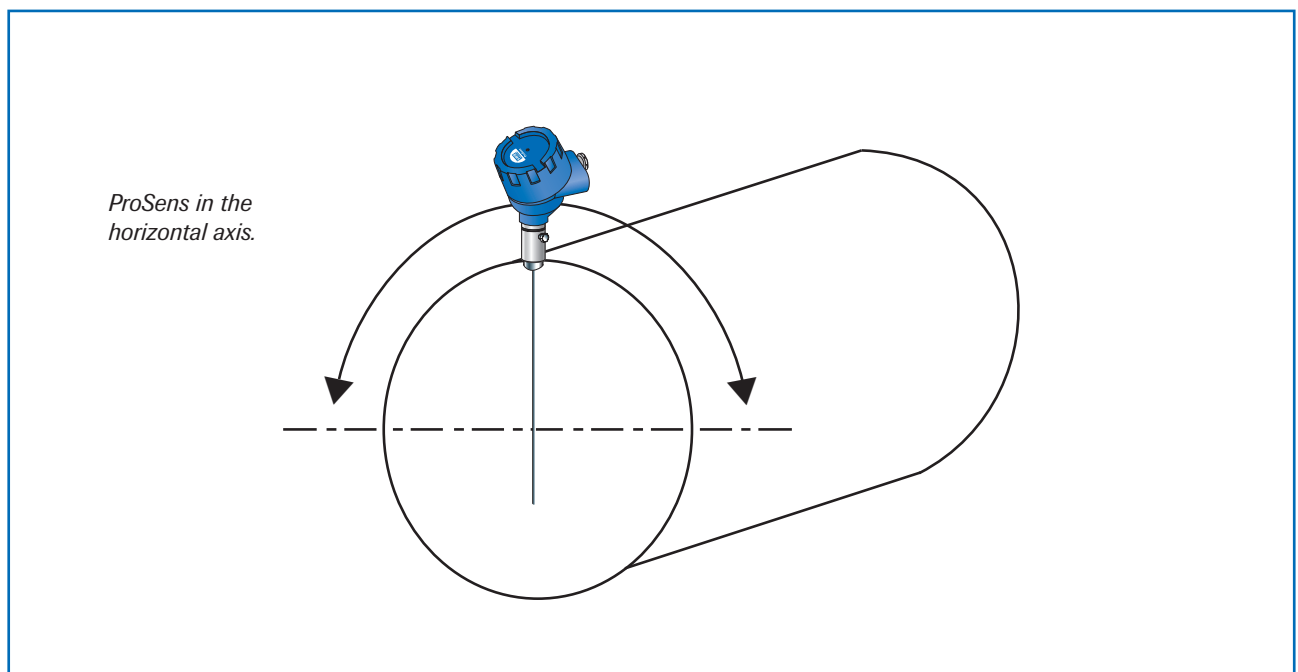

Fig. 3a: Round cross section

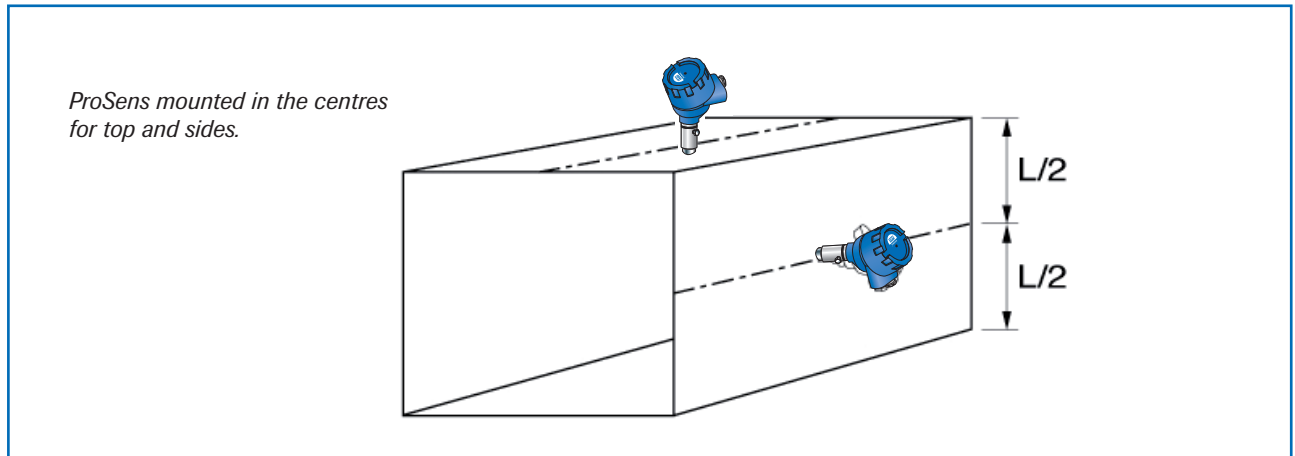

Fig. 3b: Rectangular ducts

2.2 Sensor installation

Once the location of the sensor has been selected, the R 1" female thread is welded on the duct wall and opened by drill completely.

Then the G 1" male thread, of the sensor is screwed in until the connection is tight. Sealing has to be checked.

Caution:

- Use a correct installation tool (wrench opening = S36) and turn at the G 1" location. Do not screw in the sensor manually by turning at the housing. This may lead to a faulty installation and cause damage to the sensor.
- Warranty will be void if improperly installed.

3. Safety

The ProSens was designed, built and tested for safety and is shipped in this condition. Components within the supplied system could be hazardous if not unpacked, installed, connected and commissioned by authorised qualified persons. All operating instructions must be read, and understood, before handling the system. Failure to do so will cause the warranty to be revoked.

3.1 Normal use

- The measuring system must be installed for measuring dust burden only. Other usage, or modifications, of the measuring system is not permitted.
- Only original spare parts and accessories of SWR engineering must be used.

3.2 Identification of hazards

Possible hazards, when using the measuring system, are marked by the following symbols:



Warning!

- This symbolises a situation where personal safety is at risk if used in an improper manner.



Attention!

- This symbolises the possible damage to the system, if used in an improper manner.

3.3 Operational safety

- The measuring system must be installed by trained and authorised personnel only.
- In case of maintenance-work on the pipe or on components of the ProSens-sensor, make sure that the piping is in unpressurized condition.
- Switch off the power supply for all maintenance, cleaning or inspection works on the sensor or on components within the ProSens. Follow the notes of the chapter maintenance.
- Caution, if welding is required on the pipe, remove sensor.
- The components and electrical connections must be checked for damages regularly. If a damage is found, it is to be repaired before further operation of the instruments.

3.4 Technical statement

- The manufacturer reserves the right to change any technical data, without prior notice. If any queries arise, SWR engineering will be happy to inform customers of any possible changes made.

4. Electrical connection

The ProSens is fit out with an internal wiring box, providing the plugs for different options:

Note: For EX-versions category 1 and 2 the relay contact is only available at the transmitter and not at the sensor.

4.1 Sensor connection

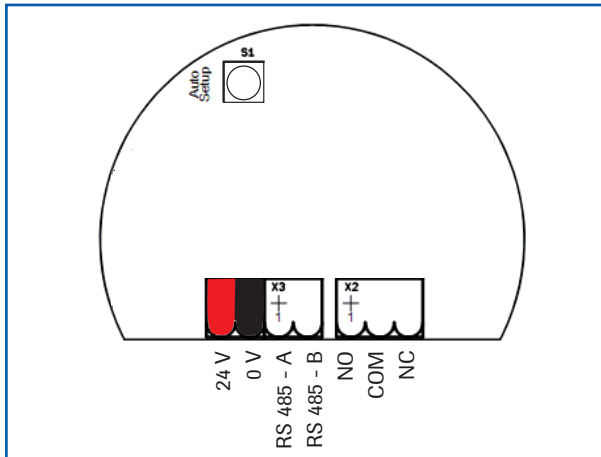

Fig. 4: Electrical connection

Plug number	Signal name
1	V+ (24 V DC)
2	V- (0 V)
3	RS 485 - A
4	RS 485 - B
5	Relay NO
6	Relay C
7	Relay NC

Tab. 1: Sensor connection

Connection to PME

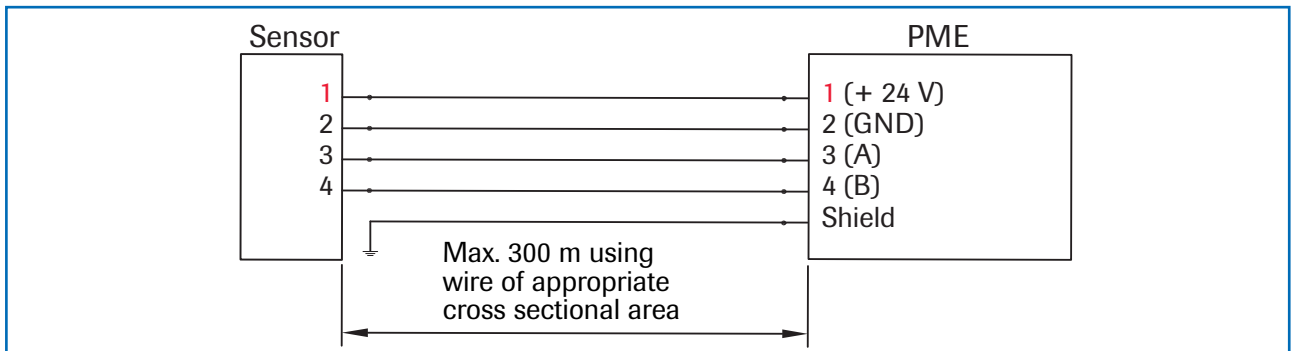

Fig. 5: Sensor connection to PME

Connection to DIN Rail Transmitter

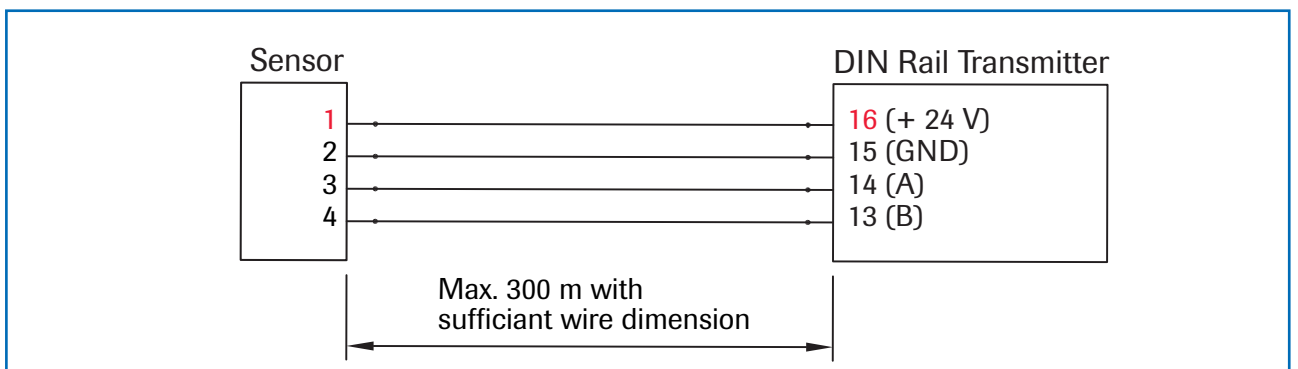

Fig. 6: Sensor connection to DIN Rail Transmitter

It is recommend that shielded, twisted cable be used for noisy environments and for long distances!

4.2 PME Transmitter

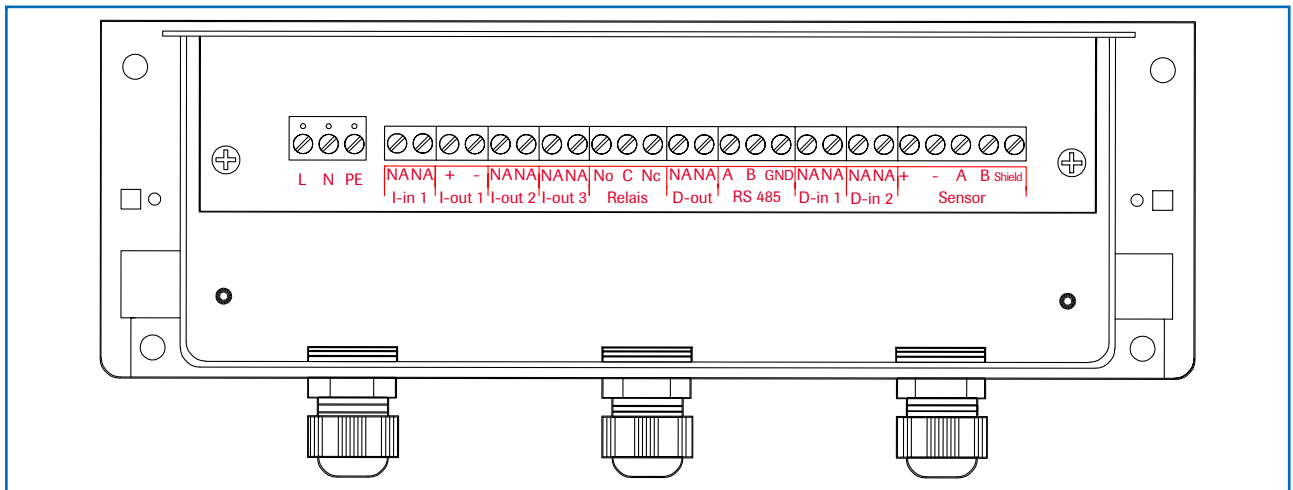

Fig. 7: PME electrical terminal

Transmitter			
Terminal no.	Connection		
Connection of the power supply			
L / +24 V	Input power supply 230 V / 50 Hz, 110 V / 60 Hz (optional 24 V DC)		
N / 0 V	Input power supply 230 V / 50 Hz, 110 V / 60 Hz (optional 24 V DC)		
PE	Protective earth		
Connections			
I-in 1	NA	not available	
	NA	not available	
I-out 1	+	Current output +	
	-	Current output -	
I-out 2	NA	not available	
	NA	not available	
I-out 3	NA	not available	
	NA	not available	
Alarm relay	NO	Isolated relay NO	
	C	Isolated relay C	
	NC	Isolated relay NC	
D-out 1	NA	not available	
	NA	not available	
RS 485	A	RS 485 interface data A (+)	
	B	RS 485 interface data B (-)	
	GND	RS 485 interface ground	
D-in 1	NA	not available	
	NA	not available	
D-in 2	NA	not available	
	NA	not available	
Sensor	+	Power supply 24 V (+)	Cable no. 1
	-	Power supply 24 V (-)	Cable no. 2
	A	RS 485 data A	Cable no. 3
	B	RS 485 data B	Cable no. 4
	Shield	Shield	Shield

Tab. 2: Connections PME

4.3 DIN Rail Transmitter

1 Current output - 4 ... 20 mA	2 Current output + 4 ... 20 mA	3 Input power supply 0 V DC	4 Input power supply + 24 V DC
5 not available	6 Alarm relay NC	7 Alarm relay C	8 Alarm relay NO

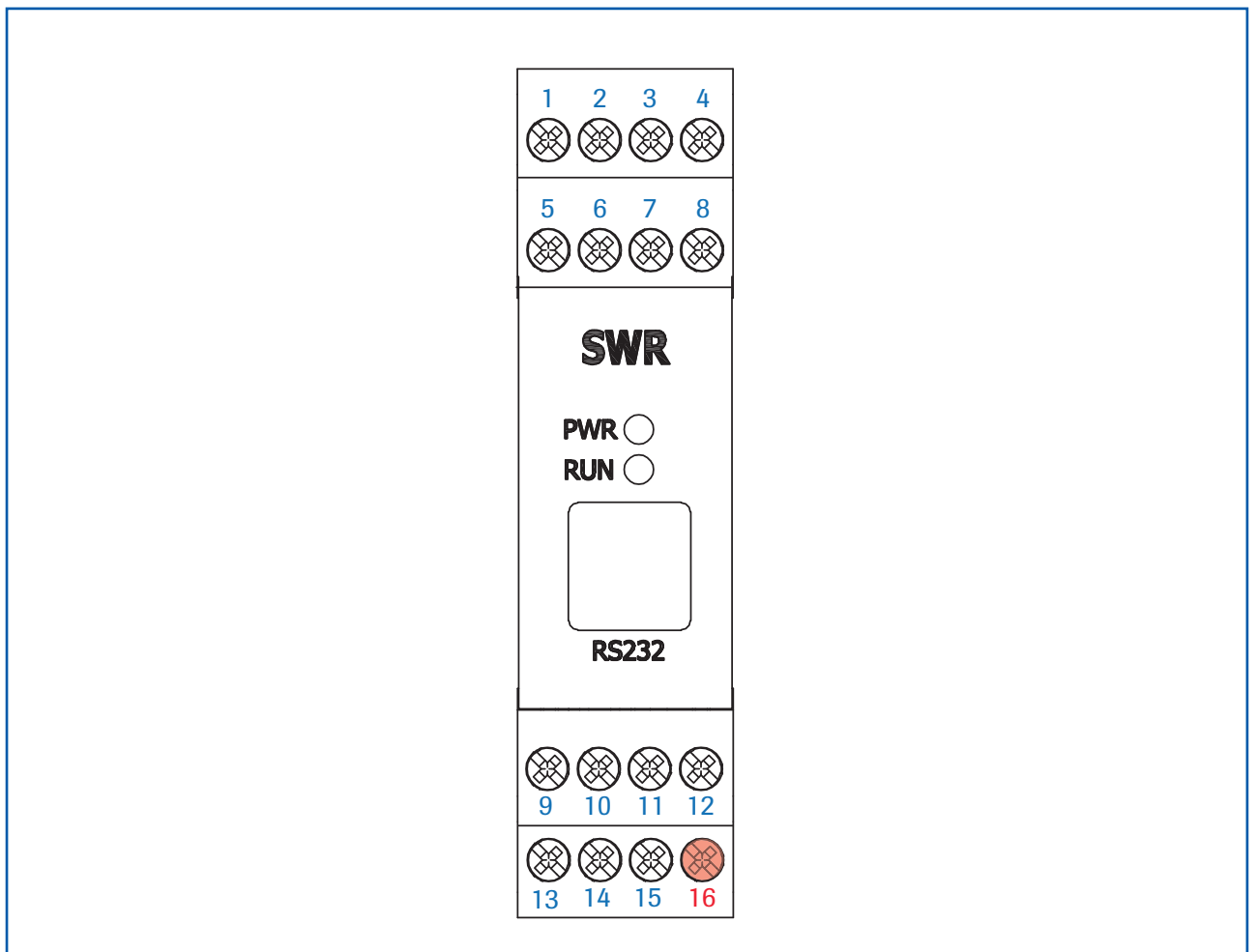

9 not available	10 not available	11 RS 485- Interface data B	12 RS 485- Interface data A
13 Sensor connection cable 4 RS 485 data B	14 Sensor connection cable 3 RS 485 data A	15 Sensor connection cable 2 Power supply 0 V	16 Sensor connection cable 1 Power supply + 24 V

Fig. 8: Terminal DIN Rail Transmitter

4.4 Connecting multiple sensors using the C3-box

As an option up to 3 sensors can be connected to the transmitter (PME or DIN Rail) via the C3-box to allow large pipe cross-sections to be monitored better.

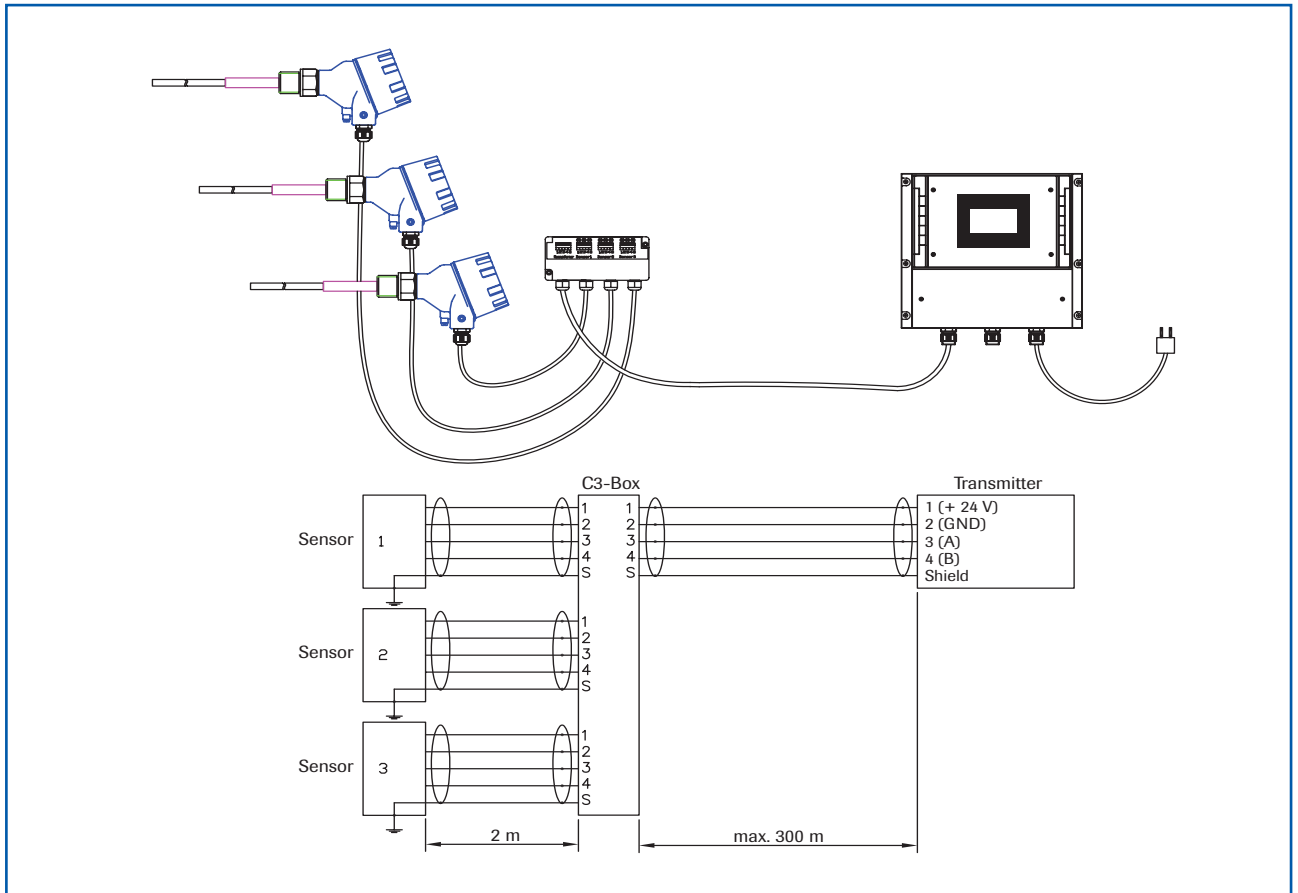

4.5 Use in Ex hazardous areas

Marking DustEx:

Ex II 1/2D Ex ia/tb IIIC Tx* °C Da/Db

***-electronics / enclosure**

Zone 20: $-20\text{ °C} \leq T_{\text{process}} \leq 250\text{ °C}$

Zone 21: $-20\text{ °C} \leq T_{\text{amb}} \leq 60\text{ °C}$

- Equipment group: 2
- Equipment category: 1/2 Electrode zone 20 / enclosure zone 21
- For explosive mixtures of air and combustible dusts
- IP-code 68
- Permitted process temperature -20 to 250 °C
- Up to process temperatures of 120 °C, the maximum surface temperature of the electronic enclosure is 120 °C. In case of higher process temperatures. At higher process temperatures the allowable surface temperature is determined by the process temperature.

Marking GasEx:

Ex II 1/2G Ex ia/d IIC T4* Ga/Gb

***-electronics / enclosure**

Zone 0: $-20\text{ °C} \leq T_{\text{process}} \leq 250\text{ °C}$

Zone 1: $-20\text{ °C} \leq T_{\text{amb}} \leq 60\text{ °C}$

The sensor is not allowed to be used in areas of class IIC, in case of expected, intense charging processes.

- Equipment group: 2
- Equipment category: 1/2 Electrode zone 0 / enclosure zone 1
- For explosive mixtures of air and combustible dusts
- IP-code 68
- Permitted process temperature -20 to 250 °C
- Up to process temperatures of 130 °C, the sensor corresponds to temperature class T4. At process temperatures up to 195 °C, the sensor corresponds to temperature class T3 and at process temperatures up to 250 °C, the sensor corresponds to temperature class T2.

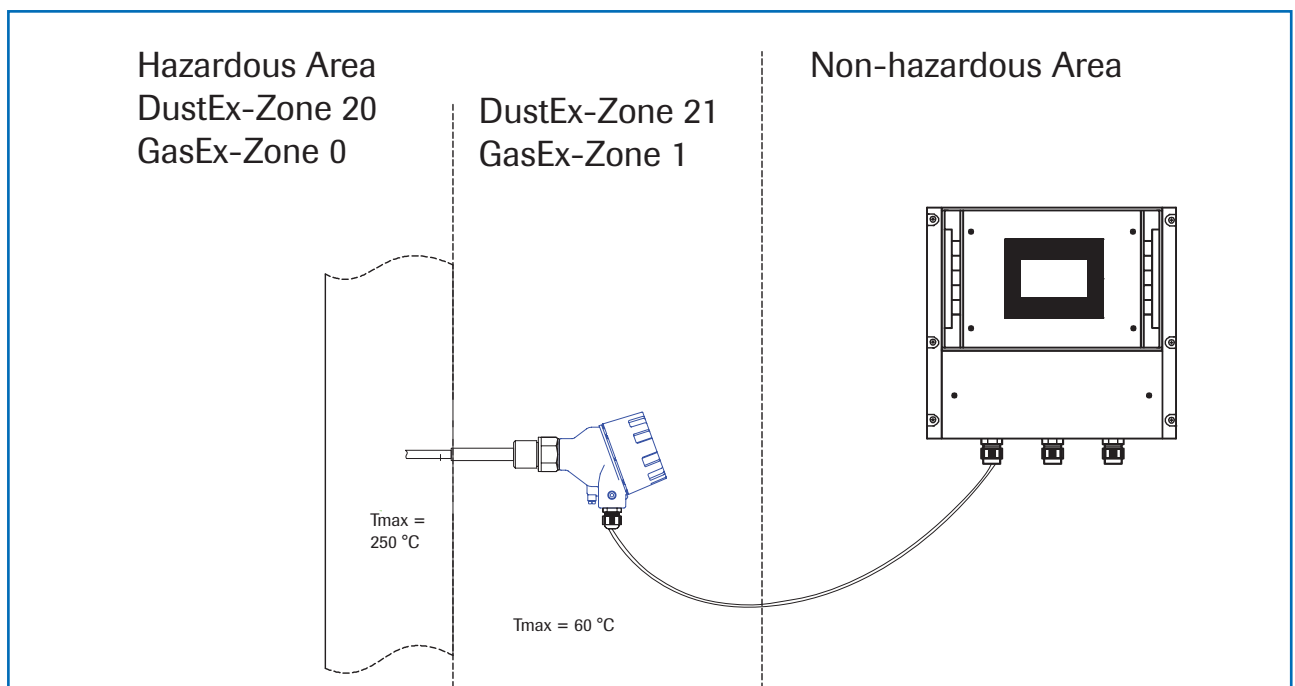

5. Dimensions

5.1 Sensor

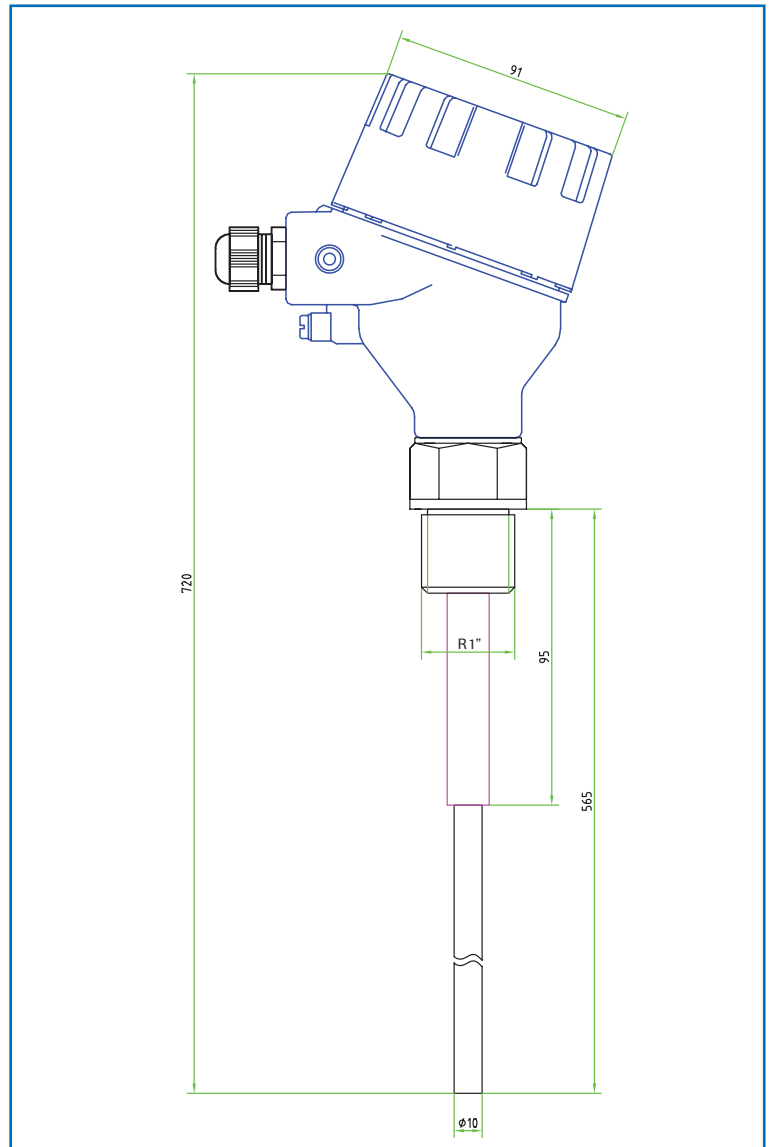

Fig. 11: Dimensions of ProSens

5.2 PME Transmitter

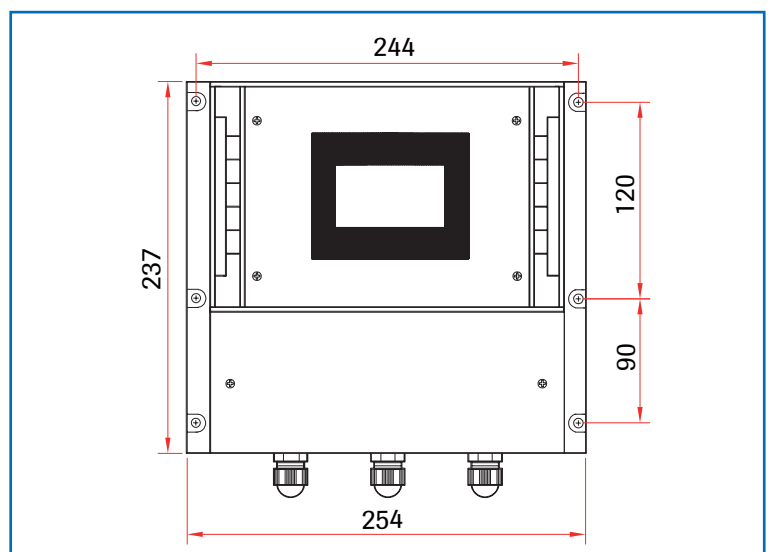

Fig. 12: Field housing, PME

5.3 DIN Rail Transmitter

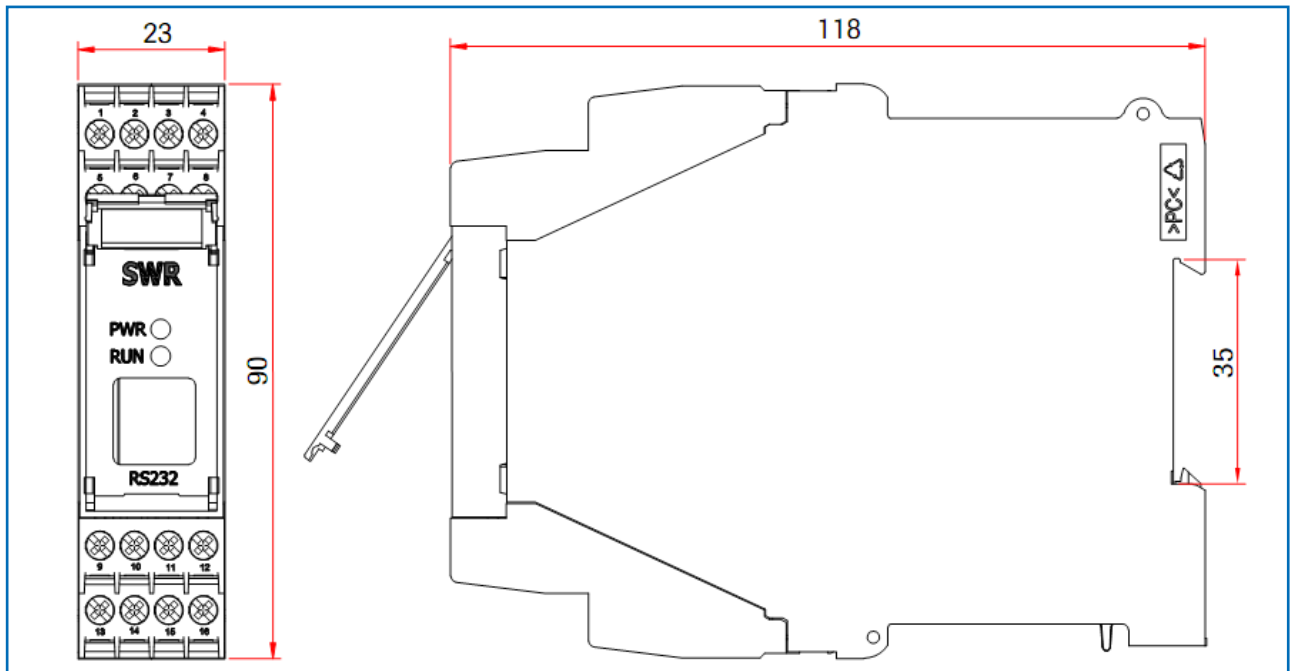

Fig. 13: Dimensions of DIN Rail Transmitter

5.4 Dimensions C1-box (optional)

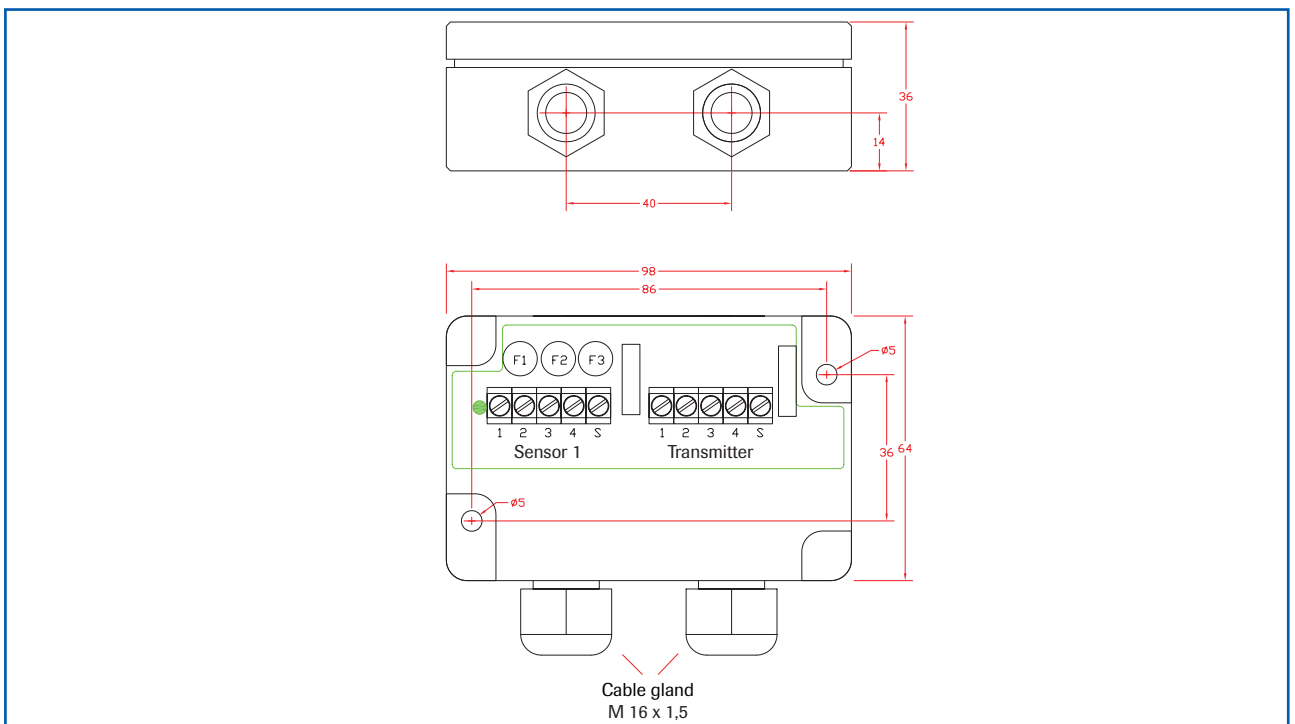

Fig. 14: Dimensions C1-box

5.5 Dimensions C3-box (optional)

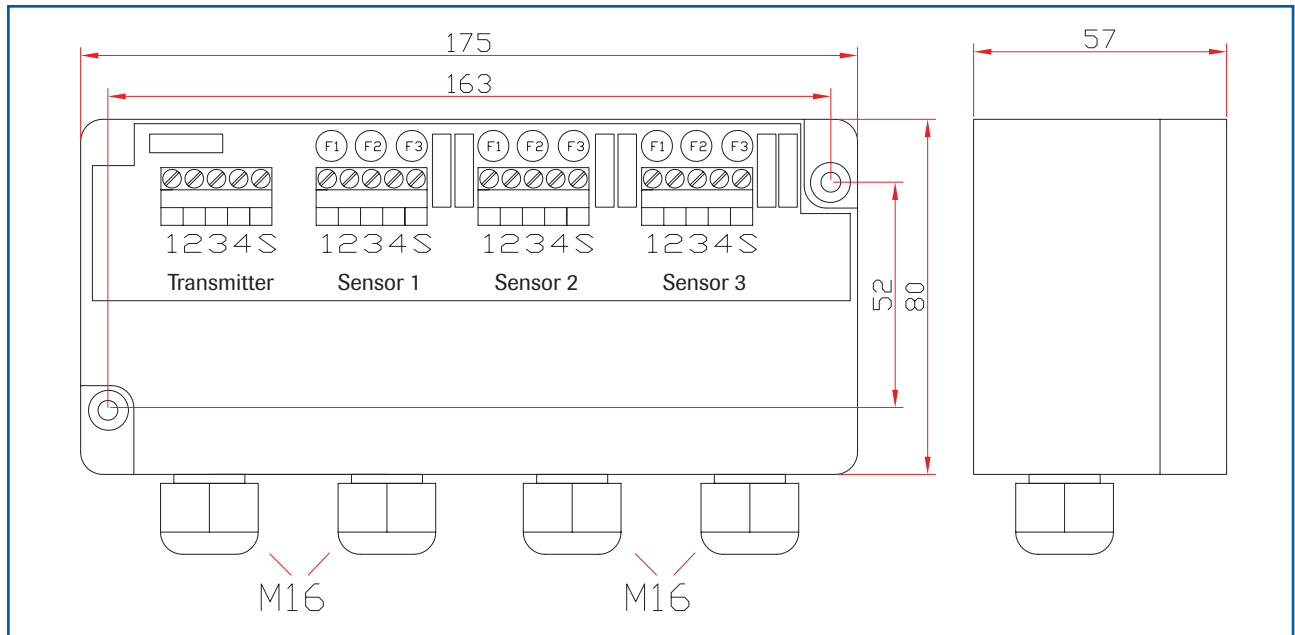

Fig. 15: Dimensions C3-box

6. Operation

As the dust travels in the duct, it has kinetic energy. When the dust strikes the sensor rod, this energy transform to static energy. A resultant coulomb charge builds up. This charge is processed to give a dust burden reading.

After power up the ProSens starts measuring using factory setting.

The commissioning with PME can be done optionally with the touchscreen or with the configuration-software. For the DIN Rail Transmitter, only PC configuration is possible.

The menu structure and numbering is identically for the touchscreen as well for the PC software. Therefore the detailed description is valid for both versions. Variations from this will be explained separately.

6.1 Basic operation of the PME-touchscreen

To enter the configuration menu press the touchscreen in the upper, right section for a few seconds.

The main menu will appear displaying the firmware version and as well four operating buttons on the right side of the screen.

- upwards button
- downwards button
- C button (in some parts of the menu named E button)
- enter button

To navigate through the menu use Up- or Down-button, to enter another level press Enter button. To leave one level or to finally leave the configuration menu press C button (cancel), as well for leaving a particular selection. In some menus this may be named E button (escape).

If a numerical value is required to be entered, a numerical keyboard will appear on the screen, for alphabetical inputs, left and right arrows select the position, the up and down arrows scroll through the selected letters.

Principally all inputs have to be confirmed by pressing the Enter button or have to be cancelled by pressing the C button (E button).

After leaving the configuration menu, prompts will appear, Save Changes, Yes or No.

At this point all changes are stored or cancelled. This section of the menu will only appear if changes have been made, if not the display will read the measured value.

6.2 Basics for PC configuration

The DIN Rail version communicates via RS 485 or RS 232 interface, the PME version via RS 485 or USB interface. The advantage of communicating via RS 485 interface is the possibility transmitting over longer distances (>100 m), the transmission distance of USB and RS 232 are only possible over short distances (< 5 m). Another advantage for RS 485 communication is the possibility to connect a many devices to one ModBus line. If there is no RS 485 interface available it is possible to order from SWR engineering.

On the PME the RS 485 cables are connected to terminals ModBus A(+) and ModBus B(-), for the DIN Rail version they are terminal numbers 12 and 11. The factory setting of the COM parameters is a Baud rate of 9600 and ModBus-address #1. The complying COM port depends to the PC configuration and will be displayed in the PC's device manager. This is valid for all three communication versions.

The termination of the RS 485 interface is by a two wire connection. The RS 232 connection to the DIN Rail Transmitter is via a specially supplied cable. For USB connection to the PME, it is suggested a standard, over the trade counter, USB cable be purchased. For first up operation, drivers for the USB to serial port have to be installed from the software CD.

On start-up of the configuration software, for first up operation, the communication parameters have to be set on the upper Left Hand Side of the software window.

If the software has been started, in the German language, right click the "Sprache: Deutsch", in the status bar, and switch to the English version.

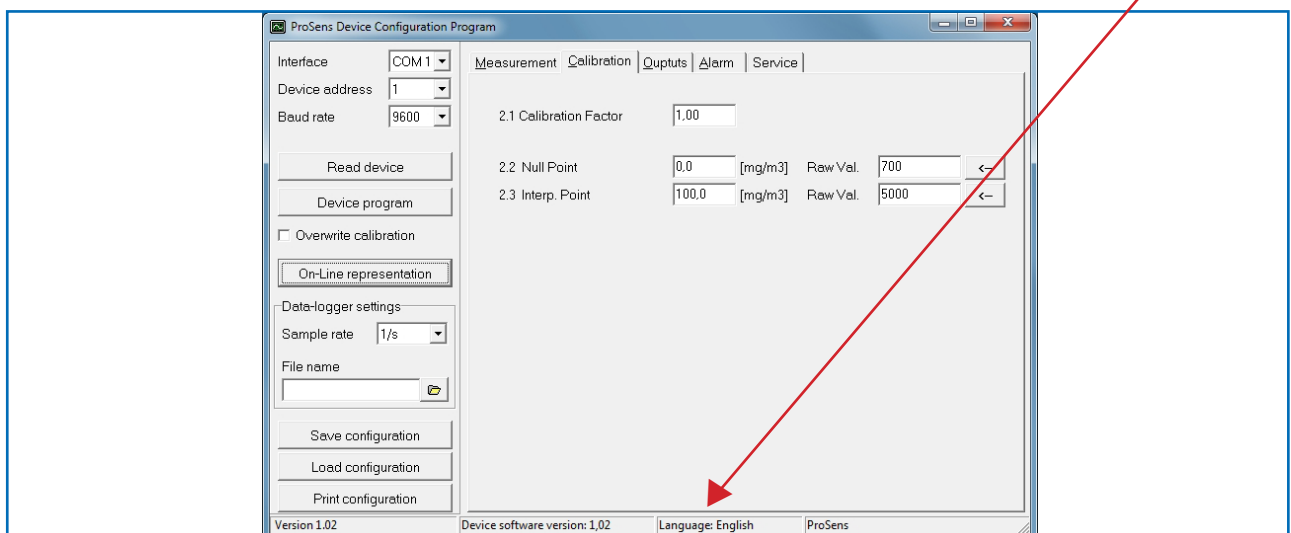

To enable communication, click the "Read device" button. If the communication has been established successfully, you will see a message "MDS-Control configuration loaded", otherwise an error message will be displayed. If this is case, cabling and parameter setting have to be checked, and the software has to be restarted.

To save any changes in the configuration, the "Device program" button on the Left Hand Side of the window has to be clicked to send the new parameters to the transmitter.

6.3 Configuration

The configuration consists of four sub menus:

1. **Measuring range**
2. **Calibration**
3. **Outputs**
4. **Alarm**

The four menu points:

The numbering of 6.3 adheres to the PME menu configuration and the same as to the PC software, not to the numbering in this manual.

1. Measuring range

- | | | |
|-----|-------------|---|
| 1.1 | Tag no. | As selected. |
| 1.2 | Unit | Option mg/m ³
g/m ³
% |
| 1.3 | Dec. place | Option 0000
000.0
00.00 |
| 1.4 | Filter time | Input 0 – 99.9 s, smoothing of the measuring value by a floating average. |

2. Calibration

(Please note, numbering of PME and PC software is different)

The principle of calibration is to give dust load values to a corresponding raw value. The raw value is a dimensionless number coming from the sensor, a low value for zero conditions (mostly from noise) and a higher level with the complying dust concentration. The higher the dust concentration, the higher the raw value.

- | | | |
|-----|---|--|
| 2.1 | Calibration factor
(Common for PME
and PC software) | Input 0.01 to 99.99, adjustment of the measured value, multiplies the calibrated measured value, used for later correction of the calibration. |
|-----|---|--|

PME-touchscreen

2.2 Zero calibration

Zero calibration (the first calibration point), acquiring of an arbitrary amount of samples. These will be incremented until triggering “Enter” or “C (cancel)” button. Preferably this will be performed in Stop condition of the airflow system.

2.3 Zero point

If there was no zero condition during calibration the reference value for this condition has to be set here.

2.4 Interpolation point calibration

Calibration point, this requires a certain number of samples. These will be incremented by triggering “Enter” or “C (cancel)” button. The unit will collect raw values and will finally calculate the average of the samples. Then a reference value has to be taken and compared to the calculated average value.

2.5 Interpolation point

Editing of the calibration point value.

PME-touchscreen- configuration

All values will be saved when leaving the configuration menu. If there has been any changes, the display will ask: “Save Changes, OK or NO”. At this point it is possible to ignore all changes.

PC software

2.2 Zero point

Zero calibration (1st calibration point), this requires a certain number of samples. To start, click Enter button, beside the raw value cell. These will be incremented by triggering “Save” or “Abort” button. Zero calibration should be performed without any flow.

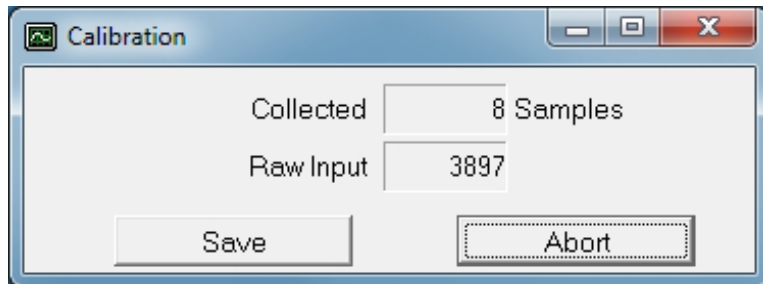

2.3 Interpolation point

Interpolation point calibration, this requires a certain number of samples. Click the Enter button, beside the raw value cell. These will be incremented by triggering “Save” or “Abort” button. Pressing the “Save” button will open an Input window for the reference value. This can be edited at a later stage.

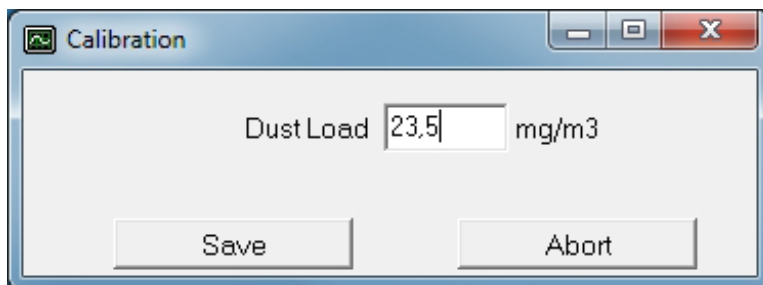

Calibration point and raw values can be edited at any stage.

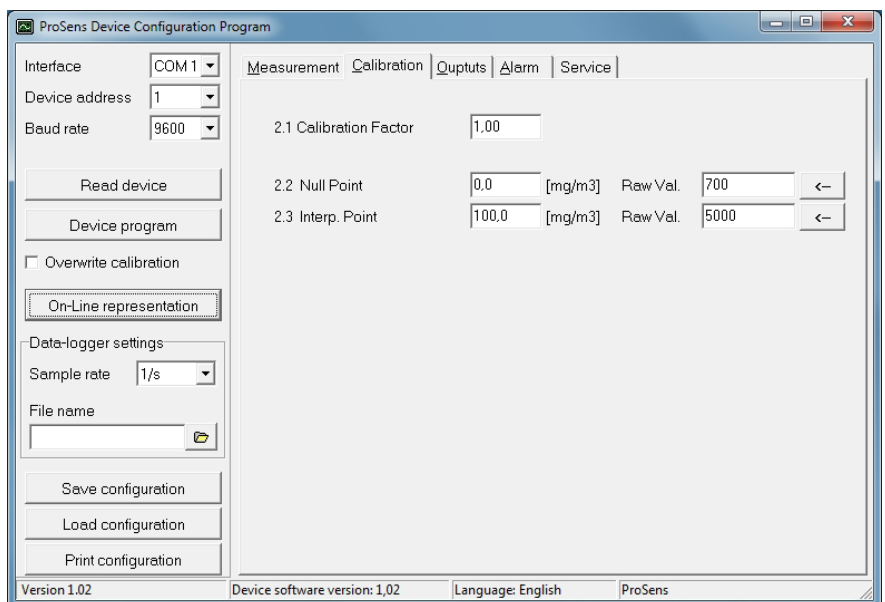

PC configuration

To save this calibration values it is necessary to activate the check box “Overwrite Calibration” on the left side of the window and also click the “Device program” button. This must be done in order to save the results.

3. Outputs

- | | | |
|-----|-------------------------------|--|
| 3.1 | 4 ... 20 mA
output scaling | 4 mA is 0 (% , mg/m ³ , g/m ³),
the value for 20 mA (% , mg/m ³ , g/m ³) is set here. |
| 3.2 | Test 4 mA | If necessary the 4 mA output current could be adjusted here. This is factory pre-calibrated and should not be altered. |
| 3.3 | Test 20 mA | If necessary the 20 mA output current could be adjusted here. This is factory pre-calibrated and should not be altered. |

4. Alarm

- | | | |
|-----|-------------------------------|---|
| 4.1 | Alarm types | Option:
Maximum-Alarm or Minimum-Alarm |
| 4.2 | Alarm set points | Alarm set points will be configured here. |
| 4.3 | Fleeting alarm times | This is an adjustable time setting that is used to inhibit an alarm output unless the alarm is present for this time setting. |
| 4.4 | Alarm time | This is an adjustable period of time that ensures any alarm point will be activated for this adjustable time period. |
| 4.5 | Alarm hysteresis | This is the “dead band” between a rising and decreasing alarm. |
| 4.6 | Alarm relay
operation mode | This enables switching between NO NC mode. |
| 4.7 | Sensor alarm | This will trigger an alarm as well if there is sensor error caused by cable break etc. |

The menu points

5. System

6. Service

are only available on the touchscreen of the field mounted IP 65 enclosure PME:

5. System

- | | | |
|-----|----------------|--|
| 5.1 | Baud rate | Selectable Baud rate for the ModBus communication 4800, 9600, 19200 or 38400 |
| 5.2 | ModBus address | Address for the ModBus Communication, possible value #1 up to #250 |
| 5.3 | Contrast | Contrast setting for the touchscreen |
| 5.4 | Language | Language selection: German, English or French |
| 5.5 | Sensor 1 | Enable/disable (multiple sensor systems only) |
| 5.6 | Sensor 2 | Enable/disable (multiple sensor systems only) |
| 5.7 | Sensor 3 | Enable/disable (multiple sensor systems only) |

6. Service

Only for authorised persons

7. Fitting up to 3 sensors

As an option up to 3 sensors can be connected to the transmitter (PME or DIN rail) via the C3-box to allow large pipe cross-sections to be monitored better.

The sensor addresses and the registration of the sensors on the transmitter is completed at the factory and cannot be changed by the user.

The configuration is identical to the configuration of a single system:

The raw value is formed as the arithmetic mean of the raw values of the individual sensors.

The raw values of all the sensors can be viewed in the online display.

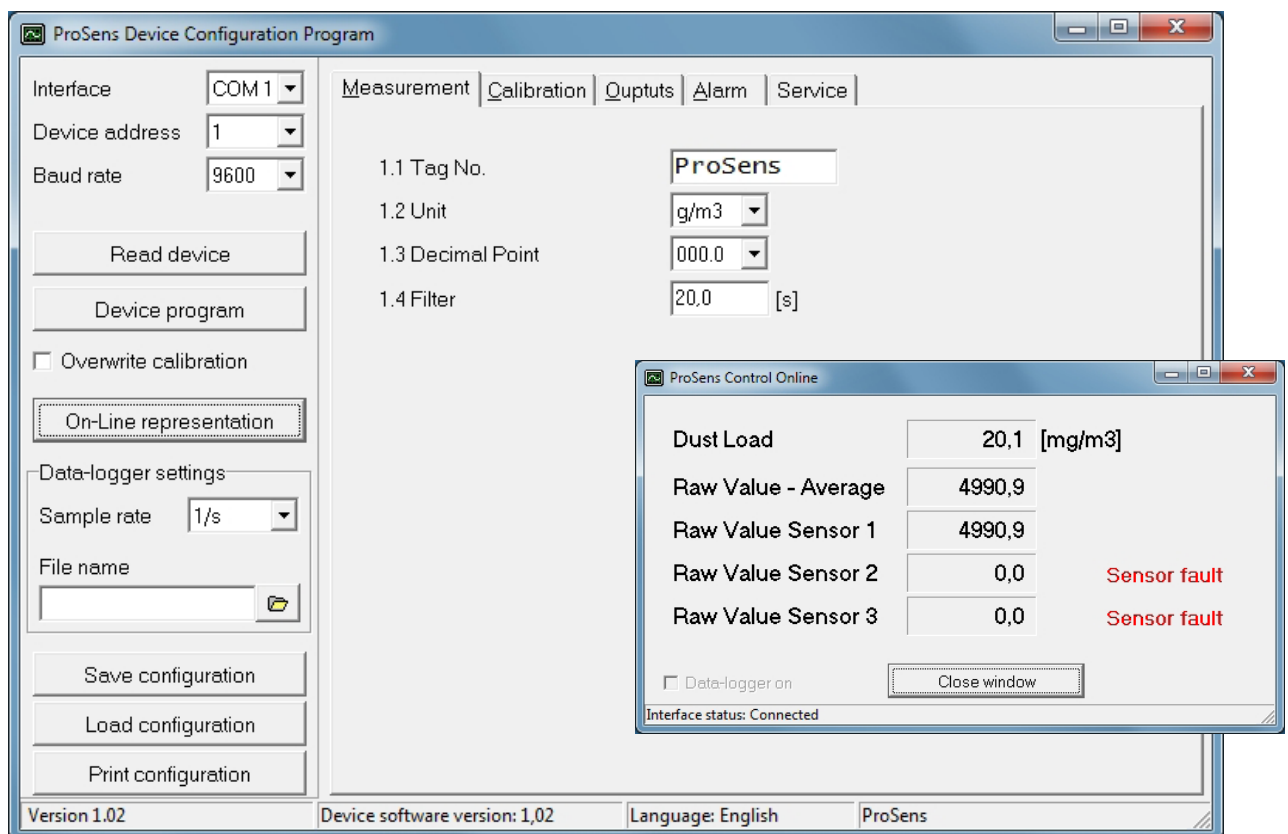

- If one sensor is missing this will cause a sensor error
- The occurrence of an internal error in a sensor will cause a sensor error
- A sensor error will be signalled as follows:
 - PME: "Sensor error" will be shown on the display
 - DIN rail: the RUN LED will flash quickly
 - Both: reduction in current output to the alarm value

8. Maintenance

Maintenance is limited to cleaning the sensor as a routine maintenance task. The sensor must be thoroughly cleaned ensuring that no particles have adhered to the rod as this could create a conductive path to ground. There is no maintenance required for the transmitter.

9. Warranty

Warranty is for one (1) year. It starts from the delivery date. The warranty is valid as long as the system has been installed and commissioned according to the Operating Instructions and there is no sign of any wear or mechanical damage.

In the case of defects during the warranty period, all defective components will be repaired / replaced. The parts that are replacing the defective parts, remain the property of SWR. If the customer requires the warranty work to be executed at their premises, then the customer will pay for costs of the SWR engineer to be on their site.

SWR is not responsible for any damage to the customer's process and is not responsible for any loss of profit due to that damage.

10. Troubleshooting

10.1 Alarm relay does not work

1. Check power supply and terminal connections.
2. Check parameter for alarm setting, are all time settings correct?

10.2 No measured value, even so after calibration

1. Check whether the process is running in a normal condition and whether there was normal conditions during calibrating. Check if there was a real zero condition during zero calibration and that there was a normal dust load during the interpolation point calibration.
2. If using the software: Has there been raw values displayed during the calibration procedure?
3. Check power supply and cabling.
4. Check for conductive and/or a short-circuit conditions between the sensor rod and the duct wall. Also check for any particles sticking to the sensor rod or any condensation surrounding the sensor rod.

If the unit still fails the before mentioned checks, please your local distributor or contact SWR engineering Messtechnik GmbH directly.

These instruments conform to the following standards:

CE	Product standard - electrical equipment for measurement, control and laboratory use - EMC requirement
	Reference standard EN 61326
	Publication year (1997) amendment(s) A1 (1998), A2 (2001), A3 (2003)

11. Technical data

Sensor	
Measuring objects	Particles in the gas flow
Measurement range	From 0.1 mg/m ³
Range setup	Pre-adjusted
Process temperature	Standard: 150 °C; optional: max. 700 °C
Ambient temperature	- 20 ... + 60 °C
Pressure	Max. 2 bar
Air speed	Min. 2 m/s
Humidity	95 % RH (non-condensing)
Measuring principle	Tribo-electricity (electrostatic detection)
Damping time	0.1 s ... 99.9 s
Sensor rod	Material: stainless steel; length: 500 / 1000
Enclosure	Aluminium
Usage in Ex-zones	Ex-zones category 1/2 gas + dust
Protection category	IP 66
Power supply	24 ± 10 % V DC from transmitter
Power consumption	1.2 W
Electrical connections	Sensor connection box DIN M 20
Measurement value alarm relay output	Relay with switching contact - Max. 250 V AC, 1 A Not for EX-devices Cat. 1 and 2
Cable (power + signal)	4 wires
Process connection	R 1" male thread
Weight	Approx. 1.5 kg

PME Transmitter	
Power supply	110 / 230 V AC; 24 V DC
Power consumption	12.5 W
Protection category	IP 65
Operating temperature	-10 ... + 60 °C
Weight	Ca. 2.5 kg
Cable cross section	0.2 - 2.5 mm ² [AWG 24-14]
Current output signal	4 ... 20 mA (0 ... 20 mA), load < 500 Ω
Alarm output	Relay output, optionally NC or NO
System error output	- max. 250 V AC, 1 A
Digital interface	ModBus (RS 485)
Data protection	Flash memory
DIN Rail Transmitter	
Power supply	24 ± 10 % V DC
Power consumption	20 W / 24 V
Protection category	IP 40 to EN 60529
Operating temperature	-10 ... + 45 °C
Dimensions	23 x 90 x 118 (B x H x T)
Weight	Ca. 172 g
Cable cross section	0.2 - 2.5 mm ² [AWG 24-14]
Current output signal	4 ... 20 mA, load < 500 Ω
Alarm output	Relay output, optionally NC or NO
System error output	- max. 250 V AC, 1 A
Digital interface	ModBus RTU (RS 485)
Data protection	Flash memory