

MANUAL

Vibracon LVL-A7H
Vibration Limit Switch

Limit Switch for Liquids in the
Food Sector



With regard to the supply of products, the current issue of the following document is applicable: The General Terms of Delivery for Products and Services of the Electrical Industry, published by the Central Association of the Electrical Industry (Zentralverband Elektrotechnik und Elektroindustrie (ZVEI) e.V.) in its most recent version as well as the supplementary clause: "Expanded reservation of proprietorship"

1	Important Document Information	3
1.1	Document Function	3
1.2	Document Conventions	3
1.3	Documentation	5
2	Basic Safety Instructions	6
2.1	Requirements for the Personnel	6
2.2	Intended Use	6
2.3	Improper Use	6
2.4	Workplace Safety	7
2.5	Operational Safety	7
2.6	Product Safety	7
3	Product Description	8
3.1	Product Design	8
4	Incoming Acceptance and Product Identification	9
4.1	Incoming Acceptance	9
4.2	Product Identification	10
4.3	Storage and Transport	11
5	Installation	12
5.1	Installation Conditions	12
5.2	Mounting the Measuring Device	18
5.3	Post-Installation Check	20
6	Electrical Connection	21
6.1	Operating Modes	21
6.2	Connecting the Device	21
6.3	Post-Connection Check	27
7	Commissioning	28
7.1	Installation and Function Check	28
7.2	LED Display	28
7.3	Function Test with Test Magnet (Optional Accessory)	30

8	Diagnostics and Troubleshooting	31
8.1	Diagnostic Information via LED Display	31
9	Maintenance	32
9.1	Cleaning	32
10	Repair, Return, and Disposal	33
10.1	Repair	33
10.2	Return	33
10.3	Disposal	33
11	Optional Accessories	34
12	Technical Data	35
12.1	Power Supply	35
12.2	Environment	35
12.3	Process	37

1 Important Document Information

1.1 Document Function

This document contains all the information that is required in various phases of the life cycle of the device: from product identification, incoming acceptance and storage, to mounting, connection, operation and commissioning through to troubleshooting, maintenance and disposal.

1.2 Document Conventions

1.2.1 Symbols Used

This document contains symbols for the identification of warning messages and of informative messages.

Warning Messages

You will find warning messages in instances, whenever dangers may arise from your actions. It is mandatory that you observe these warning messages for your personal safety and in order to avoid property damages.

Depending on the risk level, the warning messages are displayed in descending order as follows:



Danger!

This symbol indicates an imminent danger.

Non-observance will result in personal injury or death.



Warning!

This symbol indicates a possible fault or danger.

Non-observance may cause personal injury or serious property damage.



Caution!

This symbol indicates a possible fault.

Non-observance could interrupt the device and any connected systems and plants, or result in their complete failure.

Informative Symbols



Note!

This symbol brings important information to your attention.



Action

This symbol indicates a paragraph with instructions. You are prompted to perform an action or a sequence of actions.

1.2.2 Electrical Symbols



Symbol	Meaning
	Ground connection A grounded terminal which, as far as the operator is concerned, is grounded via a grounding system.
	Protective ground connection A terminal which must be connected to ground prior to establishing any other connections.

Table 1.1

1.2.3 Symbols for Certain Types of Information



Symbol	Meaning
	Allowed Indicates procedures, processes or actions that are allowed.
	Forbidden Indicates procedures, processes or actions that are forbidden.

Table 1.2

1.2.4 Symbols in Graphics

Symbol	Meaning
1, 2, 3 ...	Item numbers
A, B, C, ...	Views
A-A, B-B, C-C, ...	Sections

Table 1.3

1.2.5 Tool Symbols

Symbol	Meaning
	Hexagon wrench

Table 1.4

1.3 Documentation

Document type	Document code
Technical information	TI01148O/98/EN
Manual	BA01286O/98/EN
Certificates	ZE01010O/98/EN, overfill prevention
	ZE01011O/98/EN, leaks
	ZE01017O/98/EN, EHEDG

Table 1.5

2 Basic Safety Instructions

2.1 Requirements for the Personnel

The personnel for installation, commissioning, diagnostics and maintenance must fulfill the following requirements:

- Trained, qualified specialists must have a relevant qualification for this specific function and task
- Are authorized by the plant owner/operator
- Are familiar with federal/national regulations
- Before beginning work, the specialist staff must have read and understood the instructions in the Operating Instructions and supplementary documentation as well as in the certificates (depending on the application)
- Following instructions and basic conditions

The operating personnel must fulfill the following requirements:

- Being instructed and authorized according to the requirements of the task by the facility's owner-operator
- Following the instructions in these Operating Instructions

2.2 Intended Use

The measuring device described in these document may only be used as a limit switch for liquids. Incorrect use may pose a hazard. To ensure that the measuring device remains in proper condition for the operation time:

- the measuring devices may only be used for media against which the process-wetted materials are adequately resistant.
- the limit values in "Technical Data" must be observed.

2.3 Improper Use

The manufacturer is not liable for damage caused by improper or non-designated use.

Residual risk

Heat transfer from the process can heat up the electronics housing and the modules it contains to up to 80 °C (176 °F) during operation.

Danger of burns from contact with surfaces!

- For elevated fluid temperature, ensure protection against contact to prevent burns.

2.4 Workplace Safety

For work on and with the device:

- Wear the required personal protective equipment according to federal/national regulations.
- Switch off the supply voltage before connecting the device.

2.5 Operational Safety

Risk of injury.

- Operate the device in proper technical condition and fail-safe condition only.
- The operator is responsible for interference-free operation of the device.

2.6 Product Safety

This measuring device is designed in accordance with good engineering practice to meet state-of-the-art safety requirements, has been tested, and left the factory in a condition in which they are safe to operate.

It meets general safety standards and legal requirements. It also complies with the EC directives listed in the device-specific EC Declaration of Conformity. Pepperl+Fuchs confirms this by affixing the CE mark to the device.

3 Product Description

The Vibracon LVL-A7H is a limit switch for use in all liquids. It is used preferably in storage tanks, mixing vessels and pipes.

3.1 Product Design

The device is available in different versions which can be assembled in accordance with user specifications.

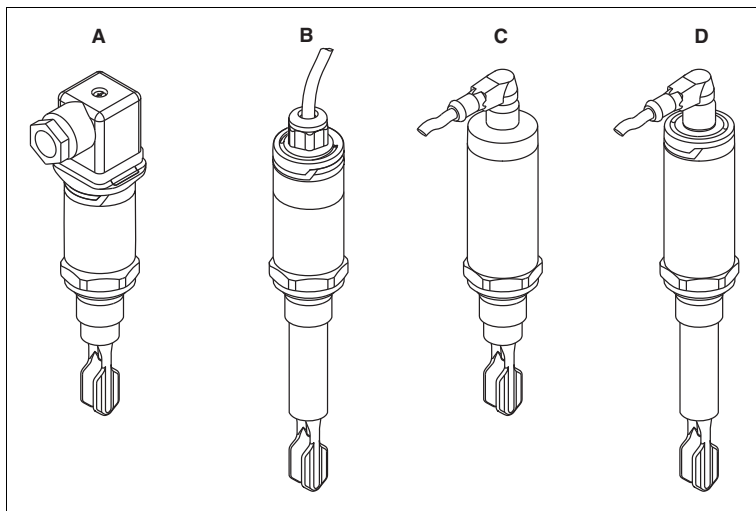

Figure 3.1

Versions	Examples			
	A	B	C	D
Electrical connection	Valve plug	Cable (cannot be dismantled)	M12 plug for housing cover IP66/68/69	M12 plug for housing cover IP65/67
Housing (sensor design) for process temperatures up to:	100 °C (212 °F)	100 °C (212 °F)	150 °C (302 °F)	150 °C (302 °F)
Sensor type	Compact version	Short tube version	Compact version	Short tube version

Table 3.1



Note!

Detailed information is available in technical information, see page 5.

4 Incoming Acceptance and Product Identification

4.1 Incoming Acceptance





	
	
<p>Is the order code on the delivery note (1) identical to the order code on the product sticker (2)?</p>	
	
<p>Are the goods undamaged?</p>	
	
<p>Do the data on the nameplates correspond to the order specifications on the delivery note?</p>	

Table 4.1

282533 2016-12

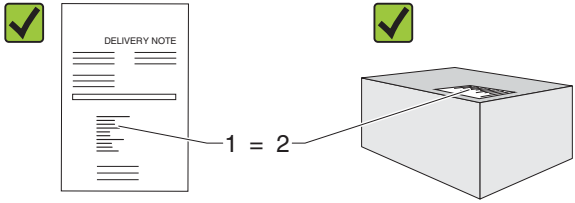
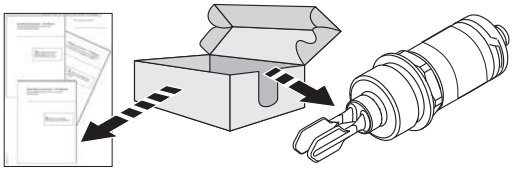

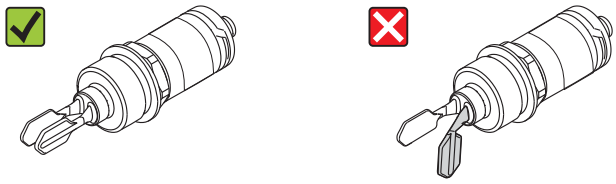
Note!

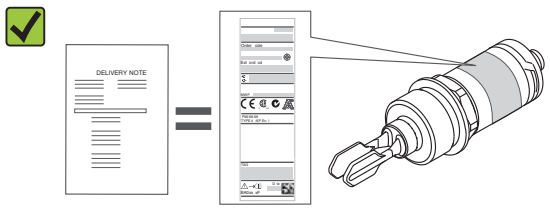
If one of these conditions is not met, please contact your Pepperl+Fuchs sales office.

4.2 Product Identification

The following options are available for identification of the measuring device:

- Nameplate data
- Order code with breakdown of the device features on the delivery note
- Scan the 2-D matrix code (QR code) on the nameplate: all the information for the measuring device is displayed.

4.2.1 Nameplate

The diagram shows a nameplate with the following fields and symbols:

- 1: Device name
- 2: Manufacturer's address
- 3: Order code
- 4: Serial number
- 5: Marking for test magnet (a circle with a crosshair)
- 6: Extended order code
- 7: Supply voltage (⊖ U:)
- 8: Signal output (⊕ I max.)
- 9: Process and ambient temperature
- 10: Process pressure
- 11: Certificate symbols (optional) including CE, c US, N12895, and a triangle with 'A' and '74-08'
- 12: Degree of protection: e. g. IP, NEMA
- 13: Certificate- and approval-specific data
- 14: Measuring point identification (optional)
- 15: Date of manufacture (year, month)
- 16: Data Matrix code
- 17: Document number of Operating Instructions

At the bottom left, there is a warning symbol (triangle with exclamation mark) and the text "BAxxxxF".



Note!

The test magnet is available as an accessory.

4.3 Storage and Transport

4.3.1 Storage Conditions

- Permitted storage temperature: -40 to +85 °C (-40 to +185 °F)
- Use original packaging.

4.3.2 Handling of the Device



Warning!

Risk of injury caused by improper use of the device

Housing or fork may become damaged or tear!

- Transport the device to the measuring point in its original packaging or by the housing.
- Do not hold the device by the fork.
- Do not use the device as a ladder or climbing aid.
- Do not bend the fork.
- Do not shorten or lengthen the fork.

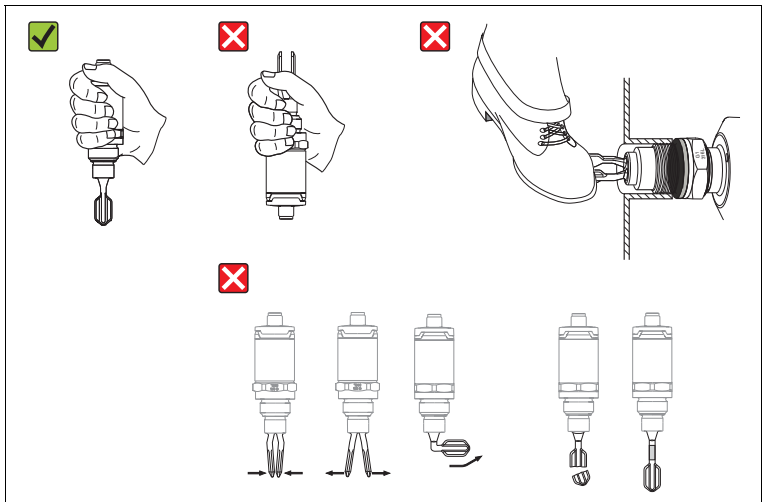

Figure 4.1 Handling of the device

5 Installation

5.1 Installation Conditions

5.1.1 Orientation

The limit switch can be installed in any position in a vessel, pipe or tank.

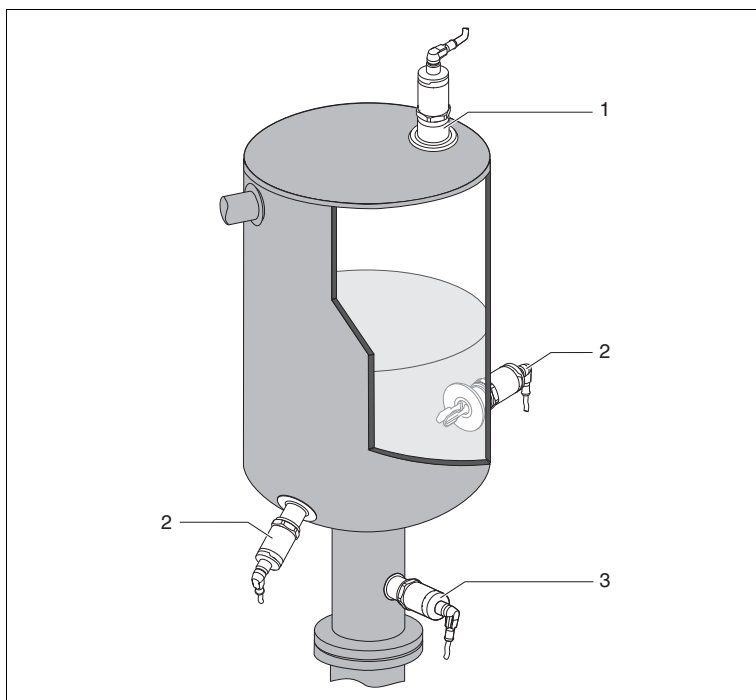

Figure 5.1 Installation options

- 1 Overfill prevention or upper level detection
- 2 Lower level detection
- 3 Dry running protection for pump

5.1.2 Switch Point

The switch point (A) on the sensor depends on the orientation of the limit switch (water +25 °C (+77 °F), 1 bar (14.5 psi)).

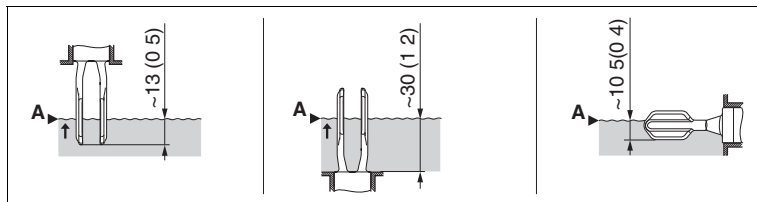

Figure 5.2 Vertical and horizontal orientation, dimensions in mm (inch)

5.1.3 Viscosity

Switching delays may occur in the case of highly viscous liquids. Ensure that the liquid can easily run off the tuning fork:

- If installing in vessels with high-viscosity liquids (A), the tuning fork may **not** be located in the installation socket!
- If installing in vessels with low-viscosity liquids (B), the tuning fork may be located in the installation socket!
- The installation nozzle must be no less than the minimum diameter of 50 mm (2.0 inch).

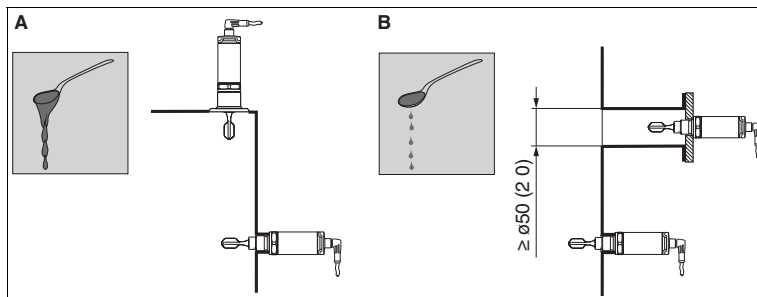

Figure 5.3 Installation options with consideration given to the liquid viscosity, dimensions in mm (inch)

- A** High viscosity (< 10000 mPa·s)
- B** Low viscosity (< 2000 mPa·s)

5.1.4

Buildup

Make sure that the installation socket does not exceed a certain length so that the tuning fork can project freely into the vessel.

Possibilities for optimization:

- A vertical orientation of the limit switch keeps buildup to a minimum.
- Preferably flush-mounted on vessels or in pipes.

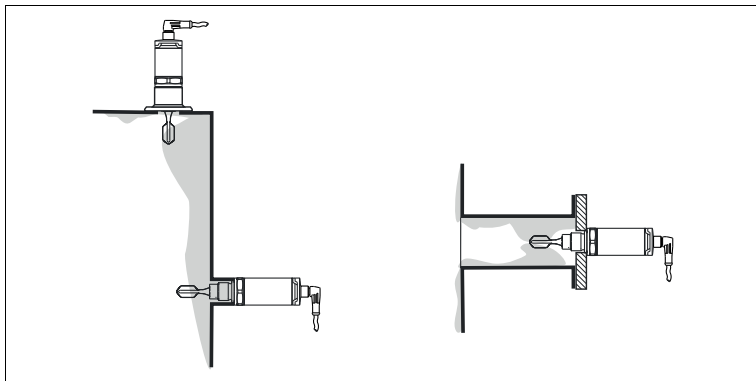

Figure 5.4 Buildup on tank wall, pipe wall and tuning fork

5.1.5 Weld-in Adapter with Leakage Hole

If installed horizontally, ensure that the leakage hole is pointing down. This allows leaks to be detected as quickly as possible.

5.1.6 Marking

The marking indicates the position of the tuning fork. If installed horizontally in vessels, the marking is face up.

The marking appears either as a material specification (e. g. 316L) or a thread designation (e. g. G1) in the following locations:

- On the hexagonal bolt of the process adapter
- On the nameplate
- On the weld-in adapter

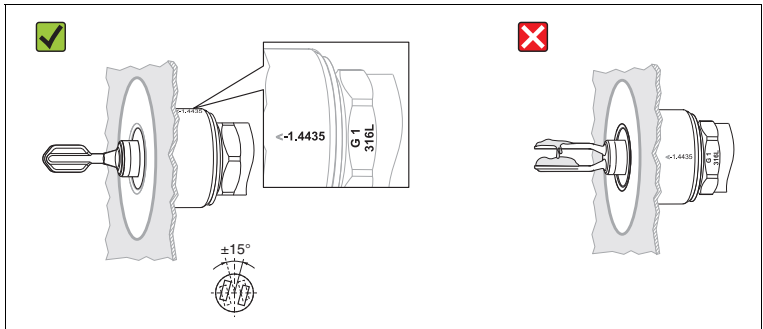

Figure 5.5 Orientation in the vessel

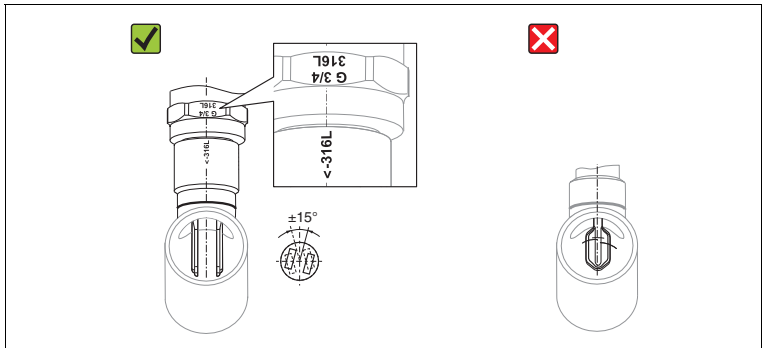

Figure 5.6 Orientation in the pipe

5.1.7

Installation in Pipes

During installation, pay attention to the position of the fork in order to minimize turbulence in the pipe.

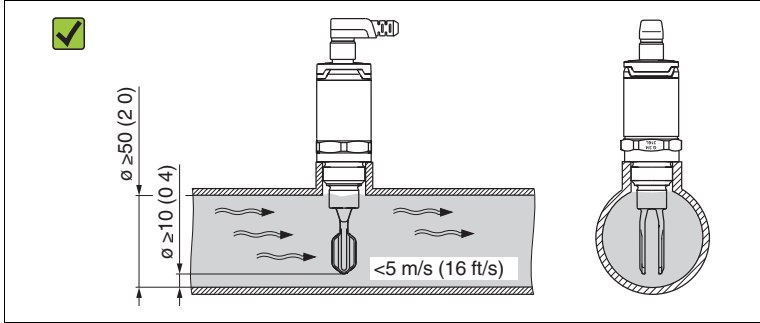

Figure 5.7

Dimensions mm (inch)

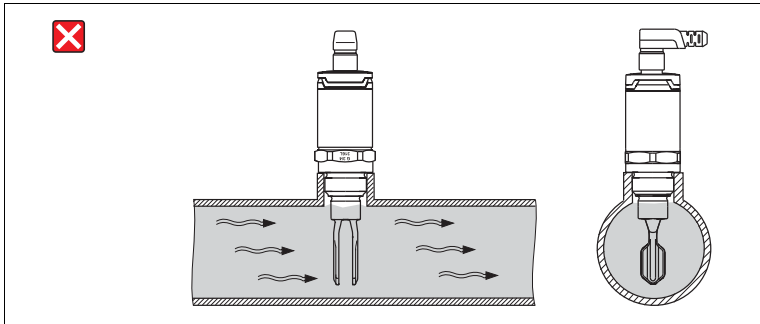

Figure 5.8

5.1.8 Installation in Vessels

If installed horizontally, pay attention to the position of the tuning fork to ensure that the liquid can drip off easily.

The electrical connection, e. g. M12 plug, should be pointing down with the cable. This can prevent moisture from penetrating.

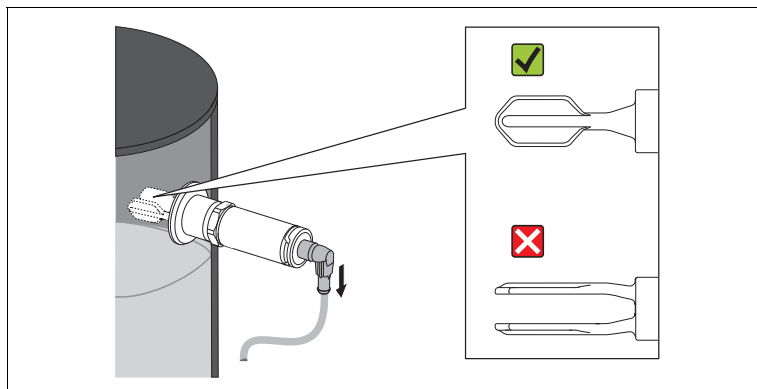

Figure 5.9 Position of the fork in the case of horizontal installation in a vessel

5.1.9 Distance from Wall

Ensure that there is sufficient distance between the expected buildup on the tank wall and the fork. Recommended distance from wall ≥ 10 mm (0.39 inch).

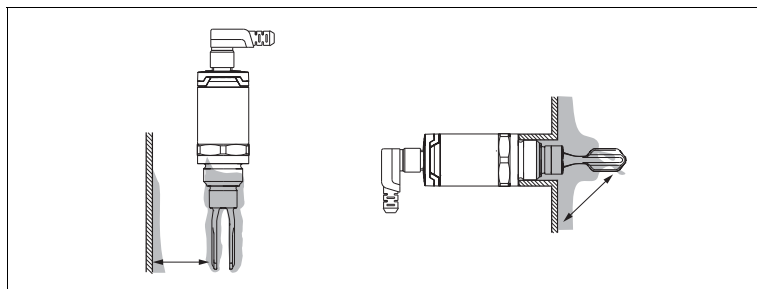

Figure 5.10

5.2 Mounting the Measuring Device



Note!

Service in accordance with WHG: Prior to mounting the device, pay attention to the WHG approval documents. The documents can be found in the download area of the Pepperl+Fuchs website: www.pepperl-fuchs.com

Required Tools

- Open-ended wrench: only turn by the hex bolt when screwing in. Maximum torque: $\leq 30 \text{ Nm}$ (22 lbf ft).
- Socket wrench: The socket wrench AF32 is available as an accessory, see page 34.



Note!

Pay attention to the temperature and pressure specifications for seals used at the customer site.

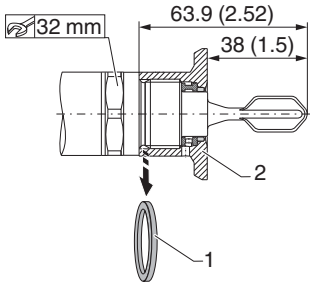
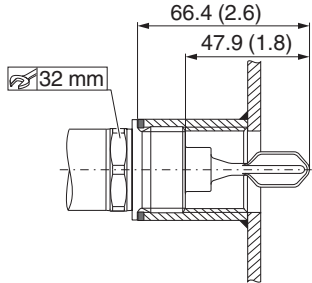
View, dimensions in mm (inch)	Description
 <p>1 Flat seal 2 Weld-in adapter</p>	<p>Thread accessory weld-in adapter Example G3/4 Pressure and temperature (maximum):</p> <ul style="list-style-type: none"> • +25 bar (+362 psi) at +150 °C (+302 °F) • +40 bar (+580 psi) at +100 °C (+212 °F) <p>When using a weld-in adapter with flush-mounted seal, the flat seal (1) supplied must be removed from the thread.</p>
	<p>Metric thread in customer nozzle Pressure and temperature (maximum):</p> <ul style="list-style-type: none"> • +40 bar (+580 psi) at +150 °C (+302 °F)

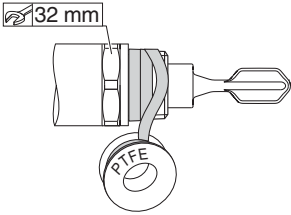
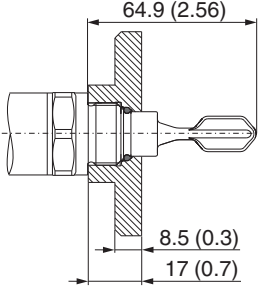
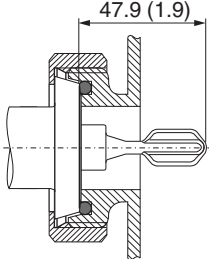
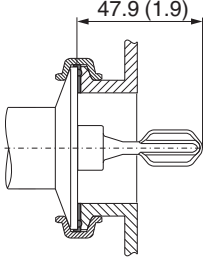
View, dimensions in mm (inch)	Description
	<p>NPT thread (ANSI B 1.20.1) Pressure and temperature (maximum):</p> <ul style="list-style-type: none"> +40 bar (+580 psi) at +150 °C (+302 °F) <p>Wrap in sealing material if necessary.</p>
	<p>Thread M24 x 1.5 for flush-mounted installation in adapter Optional accessory: process adapter Temperature (maximum):</p> <ul style="list-style-type: none"> +130 °C (266 °F) <p>Please pay attention to the different pressure ratings, see technical information, page 5. Optional accessory: weld-in adapter Pressure and temperature (maximum):</p> <ul style="list-style-type: none"> +25 bar (+362 psi) at +150 °C (+302 °F)
	<p>DIN 11851 DN25 PN40 (dairy pipe) DIN 11851 DN32 PN40 (dairy pipe) DIN 11851 DN40 PN40 (dairy pipe) Pressure and temperature (maximum):</p> <ul style="list-style-type: none"> +25 bar (+362 psi) at +150 °C (+302 °F) +40 bar (+580 psi) at +100 °C (+212 °F)
	<p>Tri-Clamp ISO 2852 DN25-38 (1 to 1-1/2 inch), DIN 32676 DN25-40 Tri-Clamp ISO 2852 DN40-51 (2 inch), DIN 32676 DN50 Pressure and temperature (maximum):</p> <ul style="list-style-type: none"> +25 bar (+362 psi) at +150 °C (+302 °F) <p>Pay attention to the temperature and pressure specifications for the seals and clips used at the customer site.</p>

View, dimensions in mm (inch)	Description
	<p>Flush-mounting in weld-in adapter Rd52, tuning fork can be aligned Scope of delivery: excluding slotted nut, excluding seal Pressure and temperature (maximum):</p> <ul style="list-style-type: none"> • +25 bar (+362 psi) at +150 °C (+302 °F) • +40 bar (+580 psi) at +100 °C (+212 °F)

Table 5.1

5.3 Post-Installation Check

- Is the device undamaged (visual inspection)?
- Does the device conform to the measuring point specifications?
 For example:
 - Process temperature
 - Process pressure
 - Ambient temperature
 - Switch point
- Are the measuring point identification and labeling correct (visual inspection)?
- Is the device adequately protected from precipitation and direct sunlight?
- Is the device secured properly?

6 Electrical Connection

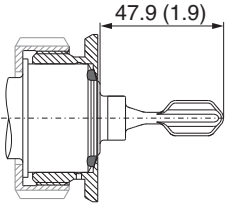
6.1 Operating Modes

The device has two operating modes: maximum safety (MAX) and minimum safety (MIN).

By choosing the corresponding operating mode, the user ensures that the device also switches in a safety-oriented manner even in an alarm condition, e. g. if the power supply line is disconnected.

- **Maximum safety (MAX)**

The device keeps the electronic switch closed as long as the liquid level is below the fork. Sample application: overflow prevention

- **Minimum safety (MIN)**

The device keeps the electronic switch closed as long as the fork is immersed in liquid. Sample application: Dry running protection for pumps

The electronic switch opens if the limit is reached, if a fault occurs or the power fails (quiescent current principle).

6.2 Connecting the Device



Note!

In accordance with IEC/EN 61010 a separate circuit breaker must be provided for the device.

6.2.1 Electronic Version 3-Wire DC-PNP

Voltage source: non-hazardous contact voltage or Class 2 circuit (North America).

M12 Plug

Depending on the analysis of the switch outputs, the device works in the MAX (maximum safety) or MIN (minimum safety) mode.





Electrical connection	Operating mode	
	MAX	MIN
		
	 	 
<ul style="list-style-type: none"> <input type="checkbox"/> Yellow LED (ye) not lit <input checked="" type="checkbox"/> Yellow LED (ye) lit K external load 		

Table 6.1

Function Monitoring with M12 Plug

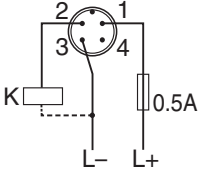
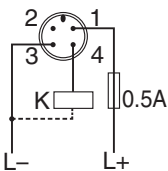
Using a two-channel analysis, function monitoring of the sensor can be implemented in addition to level monitoring, e. g. per relay switch, PLC, ...).

When both outputs are connected, the MIN and MAX outputs assume opposite states when the device is operating fault-free (XOR). In the event of an alarm condition or a line break, both outputs are de-energized.

Connection for function monitoring with antivalence		Yellow LED (ye)	Red LED (rd)
	Sensor covered	1/2 1/4	
	Sensor exposed	1/2 1/4	
	Fault	1/2 1/4	
LED lit LED not lit Fault or warning K1/K2 external load			

Table 6.2

EN

Valve Plug, Cable

Depending on the assignment of the connector or the wiring of the cable, the device works in either the MAX or MIN operating mode.







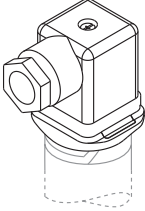
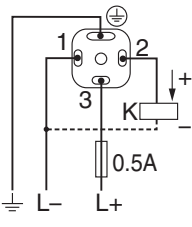

Electrical connection	Operating mode	
<p>Valve plug</p> 	<p>MAX</p>   	<p>MIN</p>   
<p>Cable (cannot be dismantled)</p>  <p>Core colors: 1 = BK (black) 2 = GR (gray) 3 = BN (brown) Ground = GNYE (green-yellow)</p>	  	  
<p> <input type="checkbox"/> Yellow LED (ye) not lit <input checked="" type="checkbox"/> Yellow LED (ye) lit K external load </p>		

Table 6.3

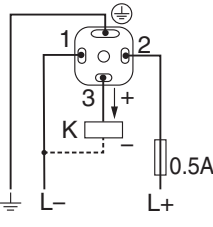
6.2.2 Electronic Version 2-Wire AC/DC

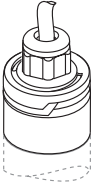
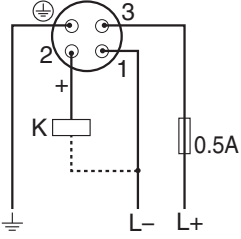
Not suitable for connection to low-voltage PLC inputs!

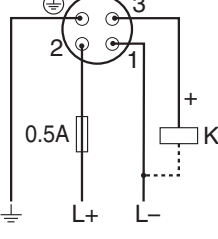
Selection tool for relays

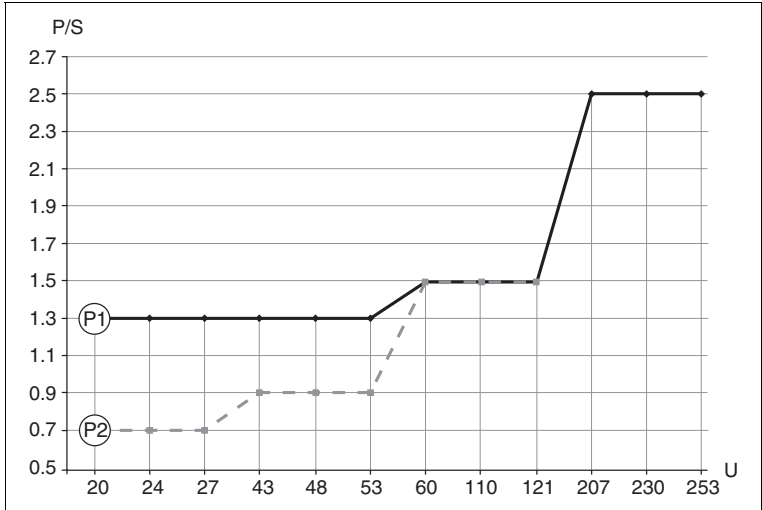

Figure 6.1 Minimum rated power of the load

P/S Rated power in [W]/[VA]

U Operating voltage in [V]

Position	Supply voltage	Rated power	
		min	max
P1 AC mode	24 V	> 1.3 VA	< 6 VA
	110 V	> 1.5 VA	< 27.5 VA
	230 V	> 2.5 VA	< 57.5 VA
P2 DC mode	24 V	> 0.7 W	< 6 W
	48 V	> 0.9 W	< 12 W
	60 V	> 1.5 W	< 15 W

Table 6.4

Relays with a lower rated power can be operated by means of an RC module connected in parallel (optional).

Valve Plug, Cable

Depending on the assignment of the connector or the wiring of the cable, the device works in either the MAX or MIN operating mode.

When the cable is wired, one wire of the cable does not have any function in each of the operating modes (brown in the case of MIN, and gray in the case of MAX). The cable with no function must be secured against inadvertent contact.



Electrical connection	Operating mode	
<p>Valve plug</p> 	<p>MAX</p> 	<p>MIN</p> 
<p>Cable (cannot be dismantled)</p>  <p>Core colors: 1 = BK (black) 2 = GR (gray) 3 = BN (brown) Ground = GNYE (green-yellow)</p>		
<p> <input type="checkbox"/> Yellow LED (ye) not lit <input checked="" type="checkbox"/> Yellow LED (ye) lit K external load </p>		

Table 6.5

6.3 Post-Connection Check

- Is the device or cable undamaged (visual check)?
- Do the cables comply with the requirements?
- Do the cables have adequate strain relief?
- Are the cable glands mounted and firmly tightened?
- Does the supply voltage match the specifications on the nameplate?
- Is the wiring correct?
- 3-wire DC-PNP: If required, is the functional earth connected?
- 2-wire AC/DC: Has the protective ground connection been established?
- If supply voltage is present, is the green LED lit?

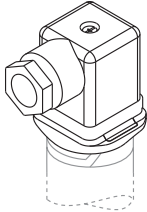
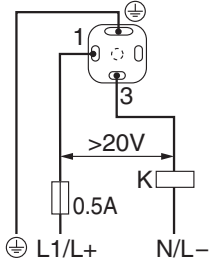
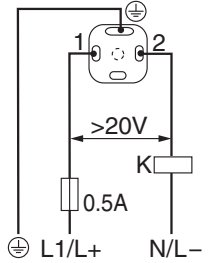
7 Commissioning

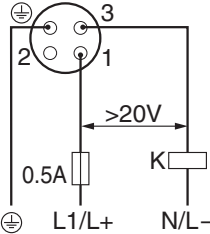
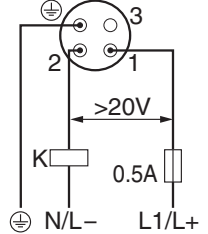
7.1 Installation and Function Check

Before commissioning your measuring point, ensure that the post-installation and post-connection checks have been performed.

- "Post-Installation Check" checklist, see page 12
- "Post-Connection Check" checklist, see page 21



Note!

The function of the tuning fork can be easily tested by immersing the tuning fork in a vessel containing water.

7.2 LED Display

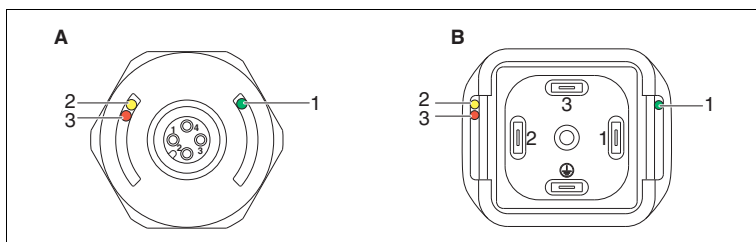

Figure 7.1

- A M12 plug, (cable without graphic)
- B Valve plug

tem	Function	Description
1	Green LED (gn) Lit	Device is operational
2	Yellow LED (ye) Lit	<p>M12 plug Indicates the sensor state: tuning fork is covered by liquid</p> <p>Valve plug/cable Indicates the switching state:</p> <ul style="list-style-type: none"> • MAX operating mode (overflow prevention): sensor is not covered by liquid • MIN operating mode (dry running protection): the sensor is covered by liquid
3	Red LED (rd) Flashing Lit	<p>Warning/maintenance required: error can be rectified, e. g. incorrect wiring</p> <p>Fault/device failure: error cannot be rectified, e. g. electronic error</p>

Table 7.1



Note!

For the metallic housing cover (IP69), there is no external signaling via LEDs. A connecting cable with an M12 connector and LED display can be ordered as an accessory.

7.2.1 Function of LEDs

Connection	Operating modes					
	Maximum safety (MAX)		Minimum safety (MIN)		Warning	Fault
1 						
2 						
3 						
4 						
5 						
1 Level display 2 M12 plug 3 M12 plug with LEDs 4 Valve plug 5 Cable		<ul style="list-style-type: none"> unlit lit flashing Fault/warning 				
LED colors: gn = green, ye = yellow, rd = red More information on LED display, see page 28.						

Table 7.2

7.3 Function Test with Test Magnet (Optional Accessory)



Warning!

Risk of injury

The function test while running processes can lead to injuries.

- Ensure that no dangerous processes are activated in the system.

To perform a function test, hold the test magnet against the marking on the nameplate (for at least 2 seconds). This inverts the current switching status and the yellow LED changes state. When the magnet is removed, the switching status valid at that time is adopted.

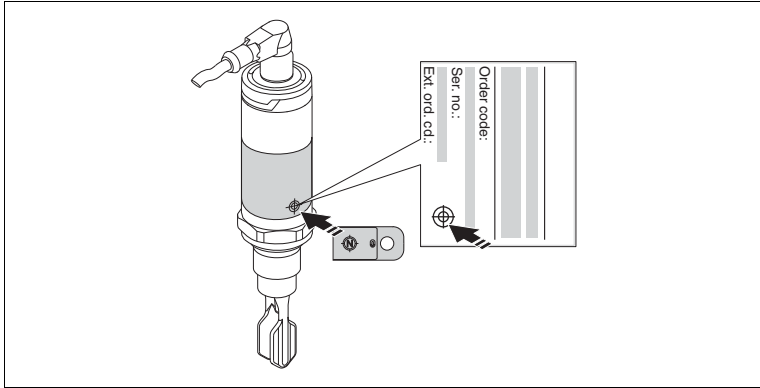

Figure 7.2 Test magnet and marking

8 Diagnostics and Troubleshooting

8.1 Diagnostic Information via LED Display

LED display on housing cover

Malfunction	Possible cause	Corrective action
Green LED Unlit	No power supply	Check connector, cable and power supply
Red LED Flashing	Overload or short-circuit inload circuit	<ul style="list-style-type: none"> Rectify short-circuit Reduce maximum load current to below 250 mA
Red LED Lit	Internal sensor failure or sensor corroded	Replace device

Table 8.1

LED display on M12 plug (available as an accessory)

Malfunction	Possible cause	Corrective action
Green LED Unlit	No power supply	Check connector, cable and power supply
Yellow LED Unlit	Internal sensor failure or sensor corroded	<ul style="list-style-type: none"> Check cable Reduce maximum load current to below 250 mA Replace device
Yellow LED Both lit		

Table 8.2

Connection: 2-Wire AC/DC to 20 to 253 V DC

Malfunction	Possible cause	Corrective action
Unexpected behavior of yellow LED	Incorrect plug assignment or incorrect cable wiring	<p>Pay attention to the polarity of the power supply!</p> <p>Correct connection: Valve plug: L+ to PIN1, L- to PIN 3 Cable: L+ BK (black), L- BN (brown)</p> <p>Result</p> <ul style="list-style-type: none"> Tuning fork covered: yellow LED lit. Tuning fork not covered: yellow LED not lit.

Table 8.3

9

Maintenance

No special maintenance work is required.

9.1

Cleaning

Do not mount a damaged or polluted device.

Clean the device if necessary. It can also be cleaned while installed (e. g. CIP = Cleaning in Place, SIP = Sterilization in Place). Take care that the device is not damaged.

10 Repair, Return, and Disposal

10.1 Repair

The device must not be repaired, changed or manipulated.

If there is a defect, always replace the device with an original device from Pepperl+Fuchs.

10.2 Return

If there is a defect, always send back the device to Pepperl+Fuchs.

Take the following precautions before you return the device to Pepperl+Fuchs.

- Remove all adhering residues from the device. These residues can be hazardous to health.
- Fill in the form "Declaration of Contamination". You can find this form on the product detail page at www.pepperl-fuchs.com.
- Enclose the filled in "Declaration of Contamination" form with the device.
- Pepperl+Fuchs can examine and repair a returned device, only if a completed form is included in the return.

If needed, include special handling instructions with the device.

Specify the following information:

- Chemical and physical characteristics of the product
- Description of the application
- Description of the error that occurred (specify error code if possible)
- Operating time of the device

10.3 Disposal

Observe the following notes during disposal:

- Observe valid federal/national regulations.
- Ensure proper separation and reuse of the device components.

11

Optional Accessories



Note!

Detailed information on accessories can be found in the technical information, see page 5.

12 Technical Data



Note!

Detailed information on accessories can be found in the technical information, see page 5.

12.1 Power Supply

Electronic version	Supply voltage	Power consumption	Current consumption
3-wire DC-PNP	10 to 35 V DC	< 975 mW	< 15 mA
2-wire AC/DC	20 to 253 V AC/DC	< 850 mW	< 3.8 mA

Table 12.1

12.2 Environment

Ambient temperature	-40 to +70 °C (-40 to +158 °F), see derating on page 36
Storage temperature	-40 to +85 °C (-40 to +185 °F)
Climate class	DIN EN 60068-2-38/IEC 68-2-38: test Z/AD
Altitude	Up to 2000 m (6600 foot) above sea level
Shock resistance	a = 300 m/s ² = 30 g, 3 planes x 2 directions x 3 shocks x 18 ms, as per test Ea, prEN 60068-2-27:2007
Vibration resistance	a(RMS) = 50 m/s ² , ASD = 1 25 (m/s ²) ² /Hz, f = 5 to 2000 Hz, t = 3 x 2 h, as per test Fh, EN 60068-2-64:2008
Reverse polarity protection	<p>2-wire AC/DC</p> <ul style="list-style-type: none"> AC mode: the device has reverse polarity protection. DC mode: in the event of reverse polarity the maximum safety mode is always detected. Check the wiring and perform a function check before commissioning. The device is not damaged in the event of reverse polarity. <p>3-wire DC-PNP</p> <p>Integrated. In the event of reverse polarity, the device is deactivated automatically.</p>
Short-circuit protection	<p>2-wire AC/DC</p> <p>During switching the sensor checks whether a load, e. g. relay or contactor, is present (load check). If an error occurs, the sensor is not damaged.</p> <p>Smart monitoring: normal operation is resumed once the error is fixed.</p> <p>3-wire DC-PNP</p> <p>Overload protection/short-circuit protection at I > 250 mA; the sensor is not destroyed.</p> <p>Smart monitoring: check for overload in intervals of approx. 1.5 s; normal operation is resumed once the overload/short-circuit is fixed.</p>
Degree of protection	<ul style="list-style-type: none"> IP65/67, NEMA 4X enclosure (M12 plug) IP66/68/69¹, NEMA 4X/6P Enclosure (M12 plug for metal housing cover) IP65, NEMA 4X enclosure (valve plug) IP65/68, NEMA 4X/6P enclosure (cable)

Electromagnetic compatibility

Electromagnetic compatibility in accordance with all relevant requirements of the EN 61326 series and NAMUR recommendation EMC (NE21). For details, refer to the EC declaration of conformity. The EC declaration of conformity is available for downloading on the product detail page of the device under "Approvals+Certificates" available for downloading (www.pepperl-fuchs.com).

Table 12.2

¹ The IP69K protection class is defined in accordance with DIN 40050, part 9. This standard was withdrawn on 2012-11-01 and replaced by DIN EN 60529. The name of the IP protection class changed to IP69 as part of this.

Derating

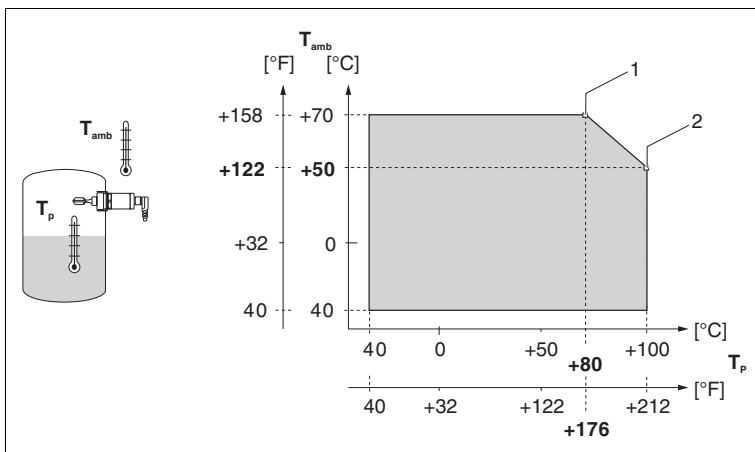

Figure 12.1 Derating curve: 100 °C (212 °F)

1 I_{max} : 250 mA (DC-PNP), 250 mA (AC/DC)

2 I_{max} : 150 mA (DC-PNP), 150 mA (AC/DC)

T_{amb} Ambient temperature

T_p Process temperature

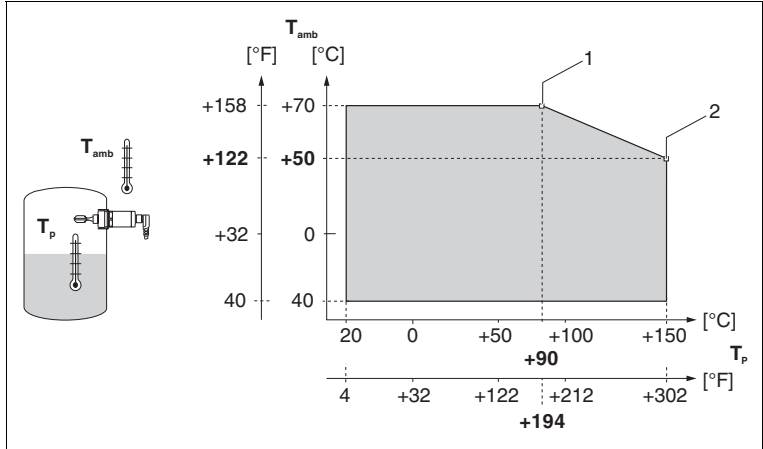

Figure 12.2 Derating curve: 150 °C (302 °F)

- 1 I_{max} : 250 mA (DC-PNP), 250 mA (AC/DC)
- 2 I_{max} : 150 mA (DC-PNP), 150 mA (AC/DC)
- T_{amb} Ambient temperature
- T_p Process temperature

12.3 Process



Note!

Pay attention to the pressure and temperature derating depending on the selected process connection.

Process temperature range	<ul style="list-style-type: none"> • -40 to +100 °C (-40 to +212 °F) • -40 to +150 °C (-40 to +302 °F)
Process pressure range	Max. -1 to +40 bar (-14.5 to +580 psi)
Density	> 0.7 g/cm ³ (optionally available: > 0.5 g/cm ³)
State of aggregation	Liquid
Viscosity	1 to 10000 mPa·s, dynamic viscosity
Solids contents	Ø < 5 mm (0.2 inch)
Lateral loading capacity	Lateral loading capacity of the tuning fork: maximum 200 N

Table 12.3

PROCESS AUTOMATION – PROTECTING YOUR PROCESS



BA012860/98/EN/03.15

Worldwide Headquarters

Pepperl+Fuchs GmbH
68307 Mannheim · Germany
Tel. +49 621 776-0
E-mail: info@de.pepperl-fuchs.com

 **PEPPERL+FUCHS**
PROTECTING YOUR PROCESS

For the Pepperl+Fuchs representative
closest to you check www.pepperl-fuchs.com/contact

282533

DOCT-4842D

12/2016

ООО “РусАвтоматизация”

454010 г. Челябинск, ул. Гагарина 5, оф. 507
тел. 8-800-775-09-57 (звонок бесплатный), +7(351)799-54-26, тел./факс +7(351)211-64-57
info@rusautomation.ru; русавтоматизация.рф; www.rusautomation.ru