

Liquid level and leakage sensors

Photoelectric sensors FFAM 17PTD1002/L

dimension drawing

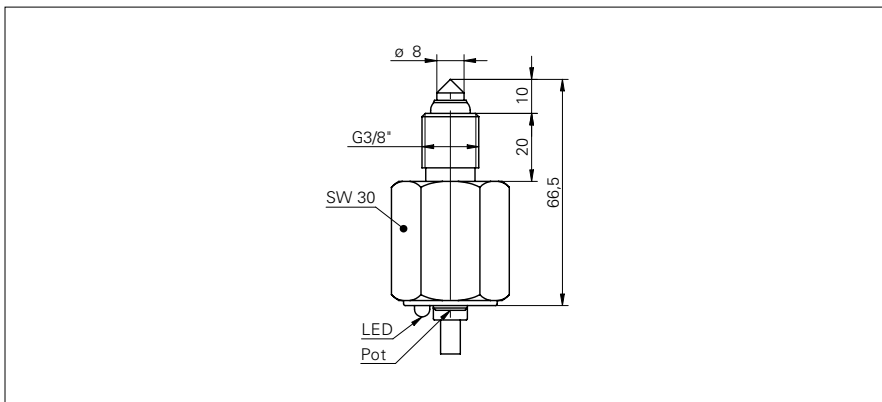

general data

type	liquid level sensor
light source	pulsed infrared diode
nominal pressure (probe tip)	40 bar
output indicator	LED yellow
sensitivity adjustment	potentiometer, 15 turn
wave length	880 nm
measurement type	contact with medium

electrical data

voltage supply range +Vs	10 ... 30 VDC
current consumption max. (no load)	15 mA
voltage drop Vd	< 2 VDC
output function	normally open (NO)
output circuit	PNP
output current	< 200 mA
short circuit protection	no
reverse polarity protection	yes, Vs to GND

mechanical data

width / diameter	30 mm
height / length	66,5 mm
thread	G 3/8"
type	cylindrical
material (sensing device)	glass (borosilicate)
housing material	stainless steel DIN 1.4305/AISI 303
connection types	cable 3 pin, 2 m

ambient conditions

operating temperature	0 ... +65 °C
protection class	IP 67

photo



connection diagram

